

# SELF-PROPELLED SCISSOR LIFTS

## PARTS MANUAL

JCPT0808HA/AC JCPT0812HA/AC JCPT1008HA/AC JCPT1012HA/AC  
JCPT1212HA/AC JCPT1412HA/AC JCPT1612HA/AC JCPT1612HAS/ACS  
JCPT1614HA/AC

(Hydraulic Motor Drive / Electric Motor Drive)



### WARNING

THE MANUFACTURER SHALL NOT BE HELD LIABLE IN CASE OF FAULTS OR ACCIDENTS DUE TO NEGLIGENCE, INCAPACITY, INSTALLATION BY UNQUALIFIED TECHNICIANS AND IMPROPER USE OF THE MACHINE

DO NOT OPERATE THIS MACHINE UNTIL YOU READ AND UNDERSTAND ALL THE DANGERS, WARNINGS AND CAUTIONS IN THIS MANUAL

Part Number: SM0120211\_Rev3.3

**CE ANSI**

Zhejiang Dingli Machinery Co., Ltd.

Third Edition, July 2021 Printing



**Version of the Record**

<b>Version Number</b>	<b>Create Date</b>
SM0120211_Rev1.0 .....	2020-10
SM0120211_Rev1.1 .....	2021-02
SM0120211_Rev2.0 .....	2021-03
SM0120211_Rev3.0 .....	2021-06
SM0120211_Rev3.1 .....	2021-08
SM0120211_Rev3.2 .....	2021-09
SM0120211_Rev3.3 .....	2021-11



## Table of Contents

### Section 1 Chassis

101.1	Steer Linkage and Wheels Assembly (Hydraulic Motor Drive) .....	2
102.1	Steer Linkage and Wheels Assembly (Electric Motor Drive) .....	5
103.1	Pothole Protection Assembly .....	8
104.1	Battery Pack Module (Lead-acid Battery) .....	11
104.2	Battery Pack Module (Lithium Battery) .....	14
105.1	Power Unit Module (Hydraulic Motor Drive).....	17
106.1	Power Unit Module (Electric Motor Drive).....	20
107.1	Ground Control Assembly .....	23
108.1	Ground Control Cover Assembly .....	24
109.1	Hydraulic Tank Assembly .....	25
110.1	Motor Controller Assembly .....	27
111.1	Pump Motor Assembly .....	28
112.1	Rear Wheel and Ladder (Hydraulic Motor Drive).....	29
113.1	Rear Wheel and Ladder (Electric Motor Drive) .....	32
114.1	Chassis Accessory Installation .....	35
115.1	Counterweight.....	37

### Section 2 Scissor

201.1	Scissor Assembly (JCPT0808HA/AC) .....	41
202.1	Scissor Assembly (JCPT0812HA/AC) .....	44
203.1	Scissor Assembly (JCPT1008HA/AC) .....	47
204.1	Scissor Assembly (JCPT1012HA/AC) .....	50
205.1	Scissor Assembly (JCPT1212HA/AC) .....	53
206.1	Scissor Assembly (JCPT1412HA/AC) .....	57
207.1	Scissor Assembly (JCPT1612HA/AC, JCPT1614HA/AC) .....	61
208.1	Scissor Assembly (JCPT1612HAS/ACS).....	64

### Section 3 Platform

301.1	Main Platform Assembly (JCPT0808HA/AC, JCPT1008HA/AC).....	70
302.1	Platform Extension Assembly (JCPT0808HA/AC, JCPT1008HA/AC) .....	73
303.1	Main Platform Assembly (JCPT0812HA/AC, JCPT1012HA/AC, JCPT1212HA/AC, JCPT1412HA/AC, JCPT1612HA/AC, JCPT1612HAS/ACS, JCPT1614HA/AC).....	75
304.1	Platform Extension Assembly (JCPT0812HA/AC, JCPT1012HA/AC, JCPT1212HA/AC, JCPT1412HA/AC, JCPT1612HA/AC JCPT1612HAS/ACS, JCPT1614HA/AC).....	78

---

305.1	Platform Locking Device Assembly .....	80
306.1	Platform Control Assembly .....	81
307.1	Platform Control Box Assembly .....	82
308.1	Protective Device Assembly (JCPT0808HA/AC, JCPT1008HA/AC) (Option) .	85
309.1	Protective Device Assembly (JCPT1012HA/AC, JCPT1212HA/AC, JCPT1412HA/AC, JCPT1612HA/AC) (Option) .....	87
<b>Section 4 Hydraulic System</b>		
401.1	Lower Lift Cylinder Assembly .....	90
402.1	Upper Lift Cylinder Assembly .....	93
403.1	Function manifold (Hydraulic Motor Drive).....	95
404.1	Function manifold (Electric Motor Drive).....	97
405.1	Hydraulic Hoses and Fittings (JCPT0808HA, JCPT0812HA, JCPT1008HA, JCPT1012HA) .....	99
406.1	Hydraulic Hoses and Fittings (JCPT0808AC, JCPT0812AC, JCPT1008AC, JCPT1012AC).....	102
407.1	Hydraulic Hoses and Fittings (JCPT1212HA, JCPT1412HA, JCPT1612HAS)	104
408.1	Hydraulic Hoses and Fittings (JCPT1212AC, JCPT1412AC, JCPT1612ACS)	107
409.1	Hydraulic Hoses and Fittings (JCPT1612HA, JCPT1614HA) .....	109
410.1	Hydraulic Hoses and Fittings (JCPT1612AC, JCPT1614AC).....	112
<b>Section 5 Electrical System</b>		
501.1	Electrical Harness (Hydraulic Motor Drive) (Lead-acid Battery).....	115
501.2	Electrical harness (Hydraulic Motor Drive) (Lithium Battery) .....	118
502.1	Electrical harness (Electric Motor Drive) (Lead-acid Battery) .....	121
502.2	Electrical harness (Electric Motor Drive) (Lithium Battery).....	125
503.1	Power to Platform.....	129
<b>Section 6 Decal</b>		
601.1	Decals with Words (CE).....	132
602.1	Decals with Symbols (CE) .....	138

# Section 1 Chassis

### 101.1 Steer Linkage and Wheels Assembly (Hydraulic Motor Drive)

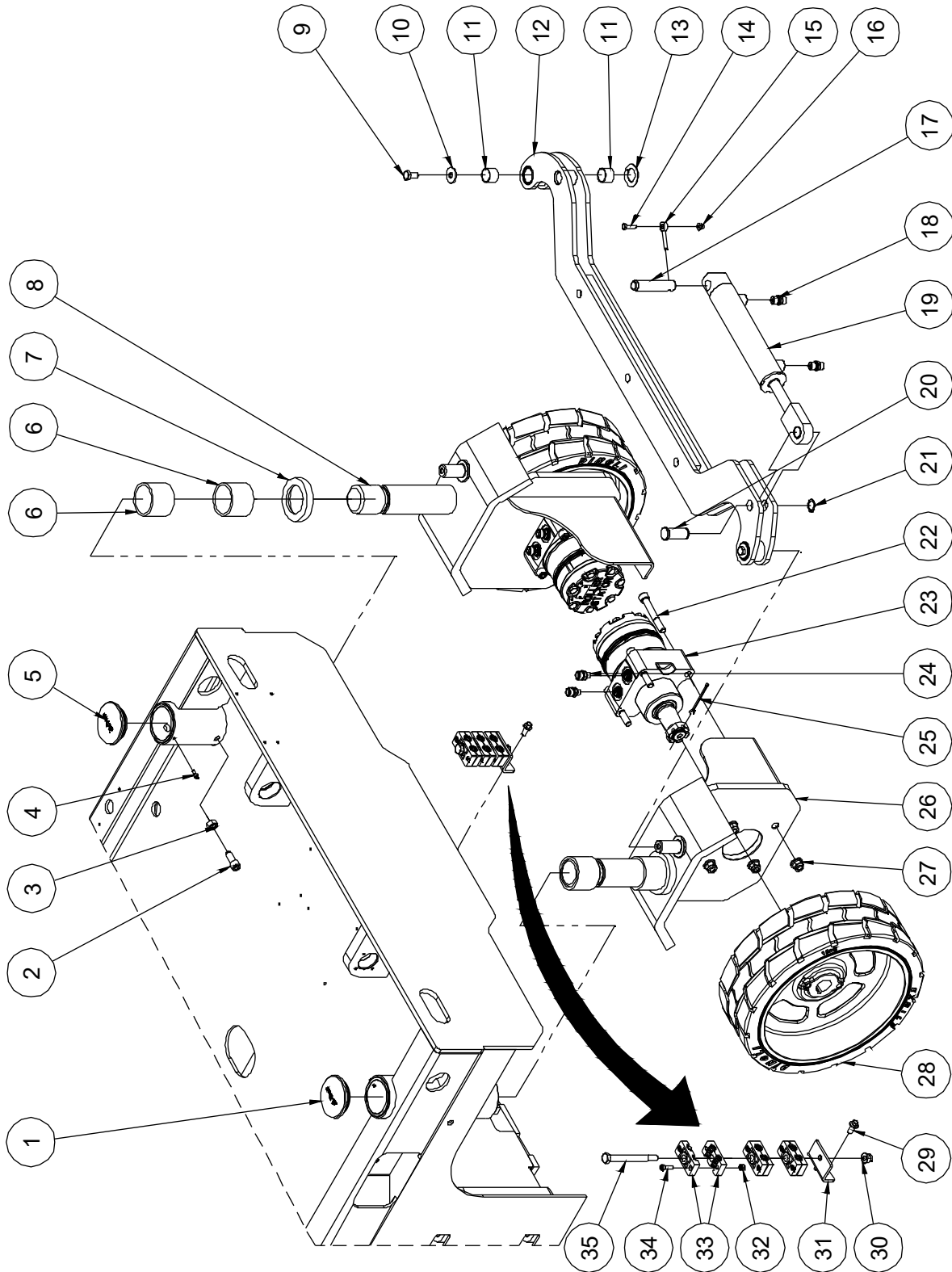

### 101.1 Steer Linkage and Wheels Assembly (Hydraulic Motor Drive)

Item	Part No.	Description	Qty.
1	10000482	Cover	1
2	10000596	Screw	2
3	00001029	Nut GB/T 6170 M12	2
4	00001252	Screw GB/T 70.1 M5×12	2
5	10000482	Cover	1
	10014395	Cover (built-in GPS antenna)	1
6	00000429	8813-556550 Bearing	4
7	10000595	Washer	2
8	10014535	Steer yoke weldment	1
9	10017932	Pin	2
10	10017933	Washer	2
11	00000368	8812-252820 Bearing	4
12	10000676	Tie rod weldment (JCPT0808HA, JCPT1008HA)	1
	10000614	Tie rod weldment (JCPT0812HA, JCPT1012HA, JCPT1212HA)	1
	10000953	Tie rod weldment (JCPT1412HA, JCPT1612HAS)	1
	10000956	Tie rod weldment (JCPT1612HA)	1
	10000873	Tie rod weldment (JCPT1614HA)	1
13	00000384	8832-26 Bearing	2
14	00000619	Bolt GB/T 5783 M6×25	1
15	00000217	8902-06045 Pin	1
16	00002574	Nut GB/T 6183.1 M6	1
17	00000571	896-20085 Pin	1
18	00001282	Straight fitting	2
19	10000451	Steer cylinder assembly (without seal kit)	1
--	00003057	Seal kit	1
20	00000267	892-20045 Pin	1
21	00000926	Circlips GB/T 894.1-20	1

### 101.1 Steer Linkage and Wheels Assembly (Hydraulic Motor Drive)

Item	Part No.	Description	Qty.
22	00005174	Screw GB/T 70.1 M12×85	8
23	00002009	Hydraulic motor (JCPT0808HA, JCPT0812HA, JCPT1008HA, JCPT1012HA)	2
	00000533	Hydraulic motor (JCPT1212HA, JCPT1412HA, JCPT1612HA, JCPT1612HAS, JCPT1614HA)	2
24	00001771	Straight fitting	4
25	00005279	Cotter pin GB/T 91 4×70	2
26	10014536	Steer yoke weldment	1
27	00002576	Nut GB/T 6183.1 M12	8
28	10000486	Wheel	2
29	00002875	Bolt QC/T 340 M8×20	2
30	00002572	Nut GB/T 6183.1 M10	1
31	10007359	Hose clamp support	1
32	00001033	Nut GB/T 6182 M6	6
33	10007360	Hose clamp	6
34	00000774	Screw GB/T 70.1 M6×20	6
35	10007362	Bolt	1

### 102.1 Steer Linkage and Wheels Assembly (Electric Motor Drive)

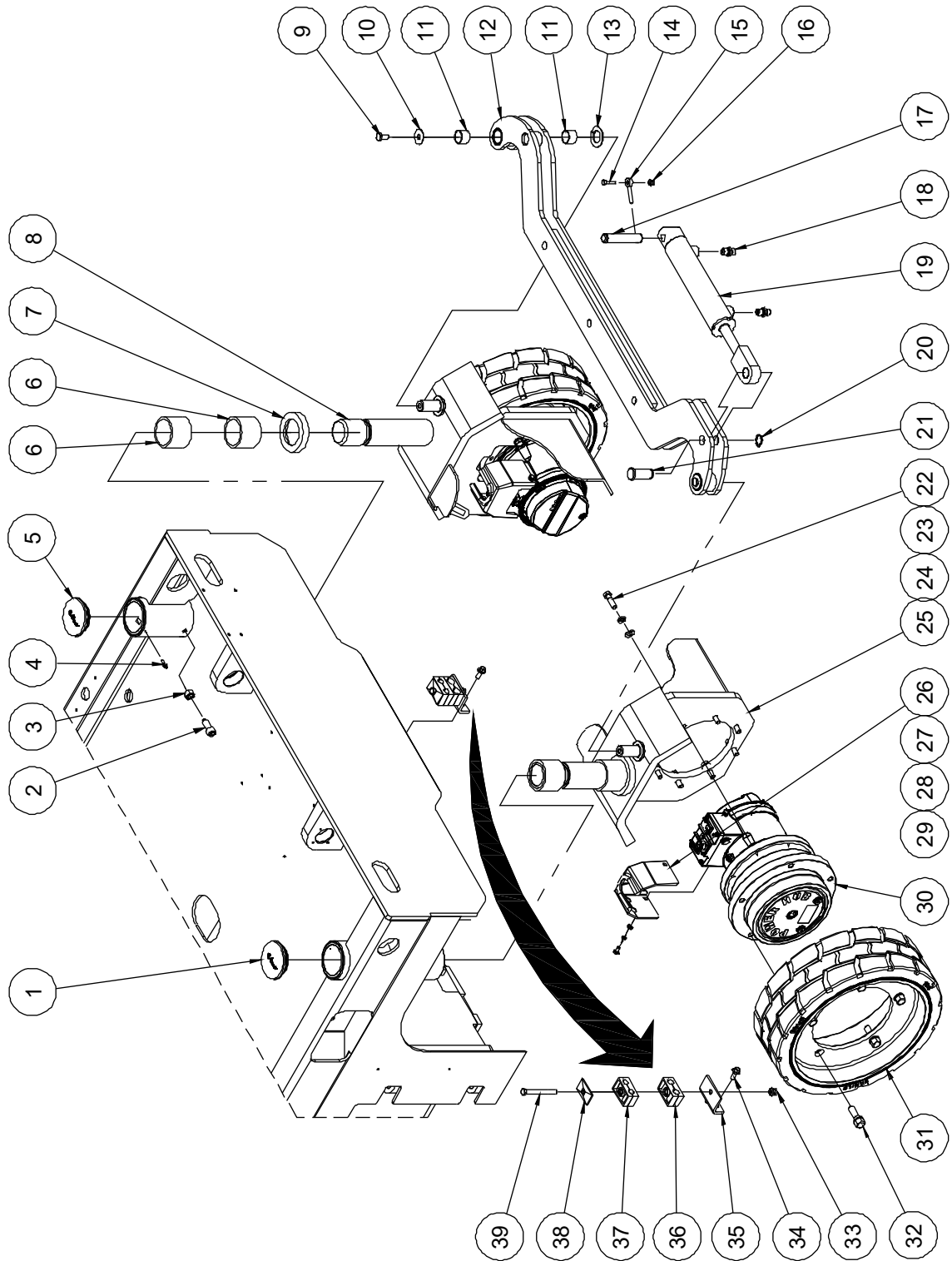

### 102.1 Steer Linkage and Wheels Assembly (Electric Motor Drive)

Item	Part No.	Description	Qty.
1	10000482	Cover	1
2	10000596	Screw	2
3	00001029	Nut GB/T 6170 M12	2
4	00001252	Screw GB/T 70.1 M5×12	2
5	10000482	Cover	1
	10014395	Cover (built-in GPS antenna)	1
6	00000429	8813-556550 Bearing	4
7	10000595	Washer	2
8	10011735	Steer yoke weldment	1
9	10017932	Pin	2
10	10017933	Washer	2
11	00000368	8812-252820 Bearing	4
12	10000676	Tie rod weldment (JCPT0808AC, JCPT1008AC)	1
	10000614	Tie rod weldment (JCPT0812AC, JCPT1012AC, JCPT1212AC)	1
	10000953	Tie rod weldment (JCPT1412AC, JCPT1612ACS)	1
	10000956	Tie rod weldment (JCPT1612AC)	1
	10000873	Tie rod weldment (JCPT1614AC)	1
13	00000384	8832-26 Bearing	2
14	00000619	Bolt GB/T 5783 M6×25	1
15	00000217	8902-06045 Pin	1
16	00002574	Nut GB/T 6183.1 M6	1
17	00000571	896-20085 Pin	1
18	00001282	Straight fitting	2
19	10000451	Steer cylinder assembly (without seal kit)	1
--	00003057	Seal kit	1
20	00000926	Circlips GB/T 894.1-20	1
21	00000267	892-20045 Pin	1

### 102.1 Steer Linkage and Wheels Assembly (Electric Motor Drive)

Item	Part No.	Description	Qty.
22	00006223	3/8-16×1 1/2" Bolt ANSI B18.2.1	14
23	00005181	Washer ANSI B18.21.1 3/8	14
24	00005182	Washer ANSI B18.22.1 narrow 3/8	14
25	10011739	Steer yoke weldment	1
26	10018072	Motor cover	2
27	00000620	Washer GB/T 97.1 6	4
28	00000621	Washer GB/T 93 6	4
29	00000745	Bolt GB/T 5783 M6×12	4
30	00008592	Drive motor assembly	2
--	00006898	Reducer	1
--	00008358	Motor	1
--	00008033	Brake	1
31	10014972	Wheel	2
32	10014971	Bolt	10
33	00002575	Nut GB/T 6183.1 M8	1
34	00002875	Bolt QC/T 340 M8×20	2
35	10000458	Hose clamp support	1
36	00000316	Hose clamp	1
37	00000538	Hose clamp	1
38	10000047	Base plate	1
39	00002892	Bolt GB/T 5782 M8×90	1

### 103.1 Pothole Protection Assembly

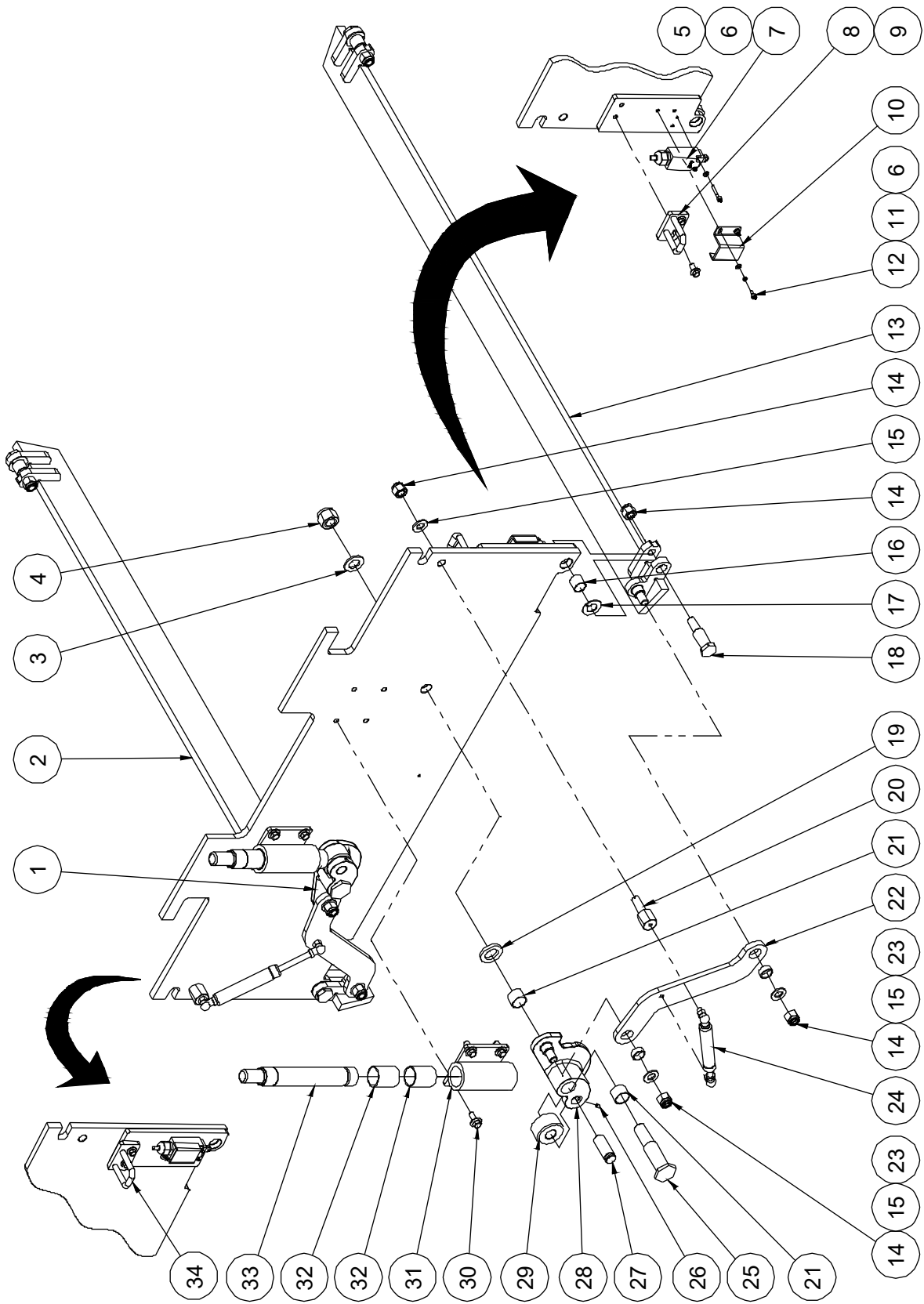

**103.1 Pothole Protection Assembly**

Item	Part No.	Description	Qty.
1	10000585	Linkage weldment (JCPT0808HA/AC, JCPT0812HA/AC, JCPT1008HA/AC, JCPT1012HA/AC, JCPT1212HA/AC, JCPT1412HA/AC, JCPT1612HA/AC, JCPT1612HAS/ACS)	1
	10000867	Linkage weldment(JCPT1614HA/AC)	1
2	10012885	Pothole guard weldment (JCPT0808HA/AC, JCPT0812HA/AC, JCPT1008HA/AC, JCPT1012HA/AC, JCPT1212HA/AC, JCPT1412HA/AC, JCPT1612HAS/ACS)	1
	10012826	Pothole guard weldment (JCPT1612HA/AC, JCPT1614HA/AC)	1
3	00001050	Washer GB/T 97.1 20	2
4	00001051	Nut GB/T 6182 M20	2
5	00001253	Screw GB/T 70.1 M5×30	4
6	00000605	Washer GB/T 97.1 5	8
7	00007930	Limit switch	2
8	10000490	Lock clasp	1
9	00002872	Bolt QC/T 340 M8×16	4
10	10000042	Switch cover	2
11	00000606	Washer GB/T 93 5	4
12	00001030	Screw GB/T 70.1 M5×10	4
13	10012883	Pothole guard weldment (JCPT0808HA/AC, JCPT0812HA/AC, JCPT1008HA/AC, JCPT1012HA/AC, JCPT1212HA/AC, JCPT1412HA/AC, JCPT1612HAS/ACS)	1
	10012824	Pothole guard weldment (JCPT1612HA/AC, JCPT1614HA/AC)	1
14	00001044	Nut GB/T 6182 M14	10
15	00001043	Washer GB/T 97.1 14	6
16	00000359	8812-202320 Bearing	4
17	00000382	8832-20 Bearing	4
18	10000575	Pin	4
19	10000573	Washer	2
20	10000569	Gas shock strut	2
21	00000368	8812-252820 Bearing	4

**103.1 Pothole Protection Assembly**

Item	Part No.	Description	Qty.
22	10000672	Pothole link plate (JCPT0808HA/AC, JCPT1008HA/AC)	2
	10000570	Pothole link plate (JCPT0812HA/AC, JCPT1012HA/AC, JCPT1212HA/AC)	2
	10000799	Pothole link plate (JCPT1412HA/AC, JCPT1612HAS/ACS)	2
	10000847	Pothole link plate (JCPT1612HA/AC, JCPT1614HA/AC)	2
23	00000356	8812-202309 Bearing	4
24	10000038	Gas shock	2
25	10000574	Pin	2
26	00001039	Screw GB/T 78 M5×10	2
27	10000572	Pin	2
28	10000584	Linkage weldment (JCPT0808HA/AC, JCPT0812HA/AC, JCPT1008HA/AC, JCPT1012HA/AC, JCPT1212HA/AC, JCPT1412HA/AC, JCPT1612HA/AC, JCPT1612HAS/ACS)	1
	10000868	Linkage weldment(JCPT1614HA/AC)	1
29	10000571	Roller	2
30	00002873	Bolt QC/T 340 M10×20	8
31	10000673	Pothole guide (JCPT0808HA/AC, JCPT1008HA/AC)	1
	10000588	Pothole guide (JCPT0812HA/AC, JCPT1012HA/AC, JCPT1212HA/AC, JCPT1412HA/AC, JCPT1612HA/AC, JCPT1612HAS/ACS, JCPT1614HA/AC)	2
32	00000390	8812-323645 Bearing	4
33	10000633	Pothole hole pusher assembly (JCPT0808HA/AC, JCPT0812HA/AC, JCPT1008HA/AC, JCPT1012HA/AC, JCPT1212HA/AC, JCPT1412HA/AC, JCPT1612HAS/ACS)	2
	10000958	Pothole hole pusher assembly (JCPT1612HA/AC, JCPT1614HA/AC)	2
34	10000491	Lock clasp	1

**104.1 Battery Pack Module (Lead-acid Battery)**

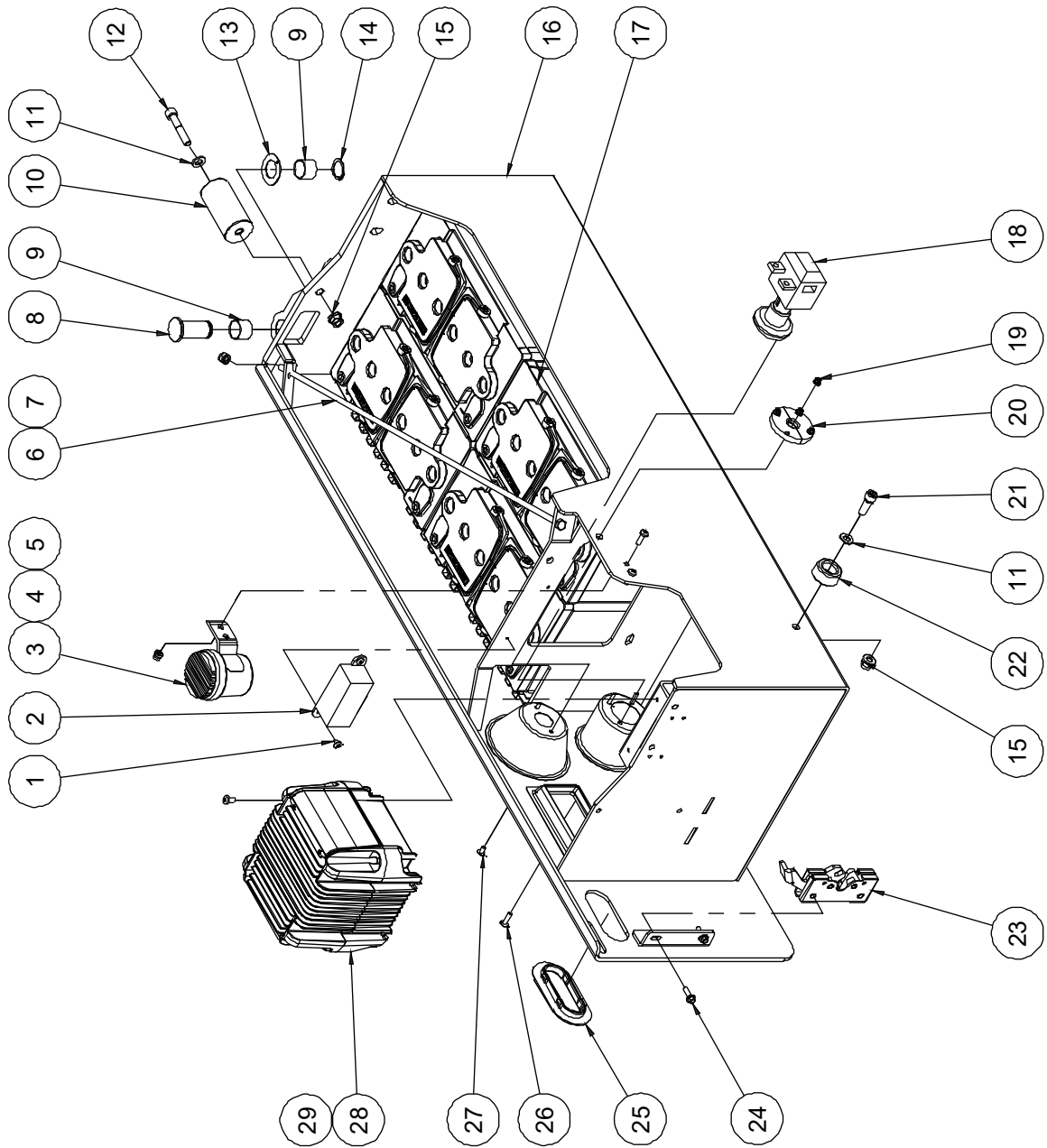

**104.1 Battery Pack Module (Lead-acid Battery)**

Item	Part No.	Description	Qty.
1	00001010	Screw GB/T 973 M5×8	2
2	00007675	300A Fuse assembly (JCPT0808AC, JCPT0812AC, JCPT1008AC, JCPT1012AC, JCPT1212AC, JCPT1412AC, JCPT1612AC, JCPT1612ACS, JCPT1614AC)	1
--	00007642	300A Fuse	1
--	00007643	Fuse block	1
2	00007674	250A Fuse assembly (JCPT0808HA, JCPT0812HA, JCPT1008HA, JCPT1012HA, JCPT1212HA, JCPT1412HA, JCPT1612HA, JCPT1612HAS, JCPT1614HA)	1
--	00007641	250A Fuse	1
--	00007643	Fuse block	1
3	00007687	Battery alarm (matching with 00000689 charger)	1
	00007683	Battery alarm (matching with 00007684 charger)	1
4	00002574	Nut GB/T 6183.1 M6	2
5	00001166	Screw GB/T 818 M6×20 - H	2
6	10000538	Threaded rod (JCPT0808HA/AC, JCPT0812HA/AC, JCPT1008HA/AC, JCPT1012HA/AC)	1
	10000793	Threaded rod (JCPT1212HA/AC, JCPT1412HA/AC, JCPT1612HA/AC, JCPT1612HAS/ACS, JCPT1614HA/AC)	1
7	00001163	Nut GB/T 6182 M8	1
8	10000536	Hinge pin	2
9	00000368	8812-252820 Bearing	4
10	10000539	Bumper	1
11	00000615	Washer GB/T 97.1 10	2
12	00002234	Screw GB/T 70.1 M10×55	1
13	00000384	8832-26 Bearing	2
14	00000992	Circlips GB/T 894.1-25	2
15	00002572	Nut GB/T 6183.1 M10	2
16	10015324	Battery tray weldment (JCPT0808HA/AC, JCPT0812HA/AC, JCPT1008HA/AC, JCPT1012HA/AC)	1
	10015307	Battery tray weldment (JCPT1212HA/AC, JCPT1412HA/AC, JCPT1612HAS/ACS)	1

**104.1 Battery Pack Module (Lead-acid Battery)**

Item	Part No.	Description	Qty.
16	10015319	Battery tray weldment (JCPT1612HA/AC, JCPT1614HA/AC)	1
17	00008417	Battery (JCPT0808HA/AC, JCPT0812HA/AC, JCPT1008HA/AC, JCPT1012HA/AC)	4
	00008416	Battery (JCPT1212HA/AC) (Need to install the liner 10018772)	4
	00008412	Battery (JCPT1412HA/AC, JCPT1612HA/AC, JCPT1612HAS/ACS, JCPT1614HA/AC)	4
18	00000655	Power switch	1
19	00002573	Nut GB/T 6183.1 M5	4
20	10000537	Half-round batten	2
21	00001059	Screw GB/T 70.1 M10×30 (JCPT0812HA/AC, JCPT1012HA/AC, JCPT1212HA/AC, JCPT1412HA/AC, JCPT1612HAS/ACS)	1
	00002234	Screw GB/T 70.1 M10×55 (JCPT1612HA/AC, JCPT1614HA/AC)	1
22	10014558	Bumper (JCPT0812HA/AC, JCPT1012HA/AC, JCPT1212HA/AC)	1
	10014559	Bumper (JCPT1412HA/AC, JCPT1612HAS/ACS)	1
	10014560	Bumper (JCPT1612HA/AC, JCPT1614HA/AC)	1
23	10000481	Latch (left)	1
24	00002866	Bolt QC/T 340 M6×20	2
25	10000540	Handle hole ring	1
26	00001013	Screw GB/T 973 M5×20	4
27	00000999	Screw GB/T 973 M5×10	2
28	00000689	Charger (GPSC)	1
	00007684	Charger (EPC)	1
29	00001060	Screw GB/T 818 M6×12 - H	4

### 104.2 Battery Pack Module (Lithium Battery)

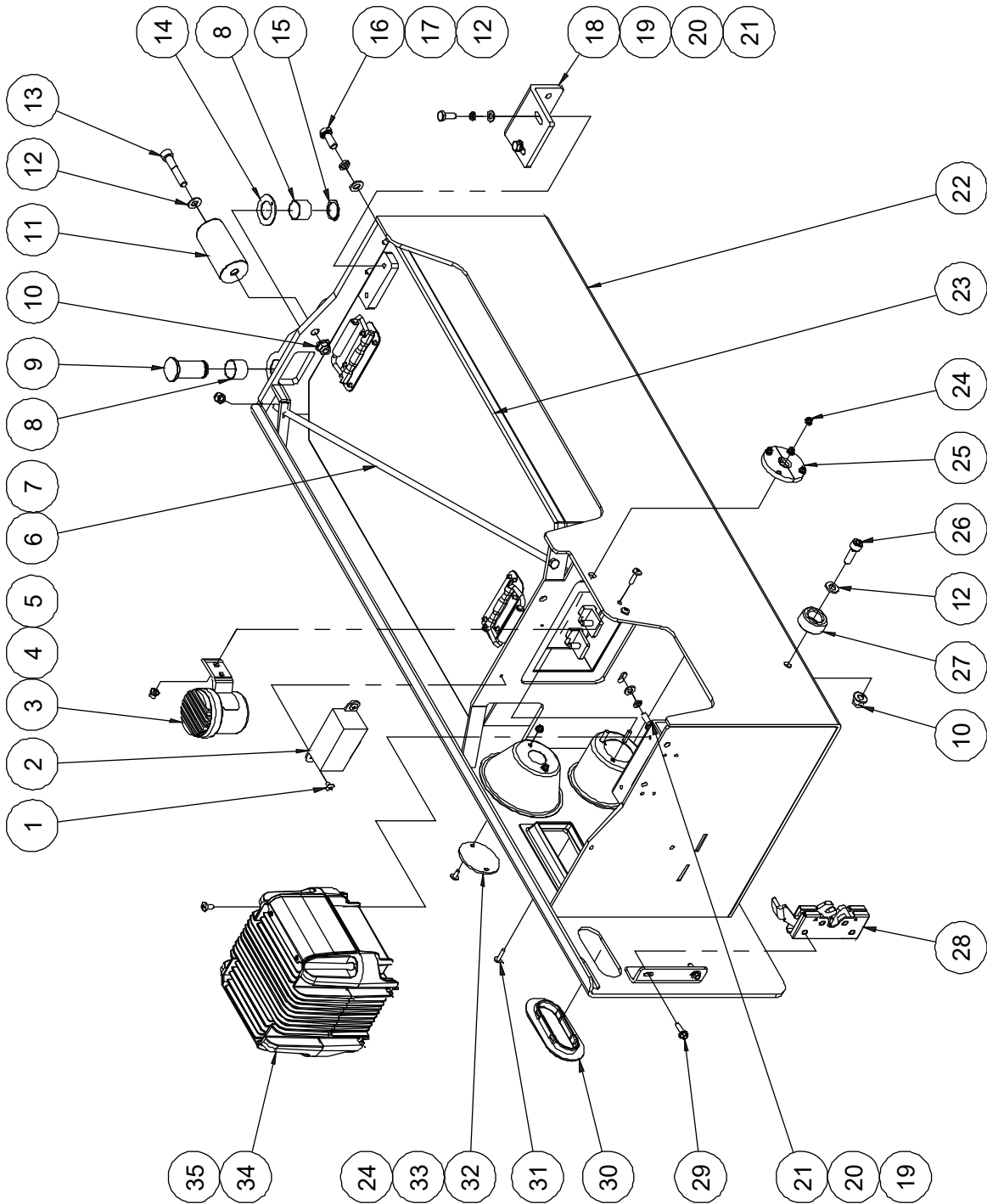

**104.2 Battery Pack Module (Lithium Battery)**

Item	Part No.	Description	Qty.
1	00001010	Screw GB/T 973 M5×8	2
2	00007675	300A Fuse assembly (JCPT0808AC, JCPT0812AC, JCPT1008AC, JCPT1012AC, JCPT1212AC, JCPT1412AC, JCPT1612AC, JCPT1612ACS, JCPT1614AC)	1
--	00007642	300A Fuse	1
--	00007643	Fuse block	1
2	00007674	250A Fuse assembly (JCPT0808HA, JCPT0812HA, JCPT1008HA, JCPT1012HA, JCPT1212HA, JCPT1412HA, JCPT1612HA, JCPT1612HAS, JCPT1614HA)	1
--	00007641	250A Fuse	1
--	00007643	Fuse block	1
3	00007687	Battery alarm (matching with 00000689 charger)	1
	00007683	Battery alarm (matching with 00007684 charger)	1
4	00002574	Nut GB/T 6183.1 M6	2
5	00001166	Screw GB/T 818 M6×20 - H	2
6	10000538	Threaded rod (JCPT0808HA/AC, JCPT0812HA/AC, JCPT1008HA/AC, JCPT1012HA/AC)	1
	10000793	Threaded rod (JCPT1212HA/AC, JCPT1412HA/AC, JCPT1612HA/AC, JCPT1612HAS/ACS, JCPT1614HA/AC)	1
7	00001163	Nut GB/T 6182 M8	1
8	00000368	8812-252820 Bearing	4
9	10000536	Hinge pin	2
10	00002572	Nut GB/T 6183.1 M10	2
11	10000539	Bumper	1
12	00000615	Washer GB/T 97.1 10	2
13	00002234	Screw GB/T 70.1 M10×55	1
14	00000384	8832-26 Bearing	2
15	00000992	Circlips GB/T 894.1-25	2
16	00000678	Bolt GB/T 5783 M10×25	2
17	00000679	Washer GB/T 93 10	2
18	10012890	Locating plate	1

**104.2 Battery Pack Module (Lithium Battery)**

Item	Part No.	Description	Qty.
19	00000608	Washer GB/T 97.1 8	4
20	00000609	Washer GB/T 93 8	4
21	00000875	Bolt GB/T 5783 M8×20	4
22	10015324	Battery tray weldment (JCPT0808HA/AC, JCPT0812HA/AC, JCPT1008HA/AC, JCPT1012HA/AC)	1
	10015307	Battery tray weldment (JCPT1212HA/AC, JCPT1412HA/AC, JCPT1612HAS/ACS)	1
	10015319	Battery tray weldment (JCPT1612HA/AC, JCPT1614HA/AC)	1
23	00007777	Battery (JCPT0808HA/AC, JCPT0812HA/AC, JCPT1008HA/AC, JCPT1012HA/AC)	4
	00007778	Battery (JCPT1212HA/AC, JCPT1412HA/AC, JCPT1612HA/AC, JCPT1612HAS/ACS, JCPT1614HA/AC)	4
24	00002573	Nut GB/T 6183.1 M5	6
25	10000537	Half-round batten	2
26	00001059	Screw GB/T 70.1 M10×30 (JCPT0812HA/AC, JCPT1012HA/AC, JCPT1212HA/AC, JCPT1412HA/AC, JCPT1612HAS/ACS)	1
	00002234	Screw GB/T 70.1 M10×55 (JCPT1612HA/AC, JCPT1614HA/AC)	1
27	10014558	Bumper (JCPT0812HA/AC, JCPT1012HA/AC, JCPT1212HA/AC)	1
	10014559	Bumper (JCPT1412HA/AC, JCPT1612HAS/ACS)	1
	10014560	Bumper (JCPT1612HA/AC, JCPT1614HA/AC)	1
28	10000481	Latch (left)	1
29	00002866	Bolt QC/T 340 M6×20	2
30	10000540	Handle hole ring	1
31	00001013	Screw GB/T 973 M5×20	4
32	10014940	Cover	1
33	00001011	Screw GB/T 973 M5×12	2
34	00000689	Charger (GPSC)	1
	00007684	Charger (EPC)	1
35	00001060	Screw GB/T 818 M6×12 - H	4

### 105.1 Power Unit Module (Hydraulic Motor Drive)

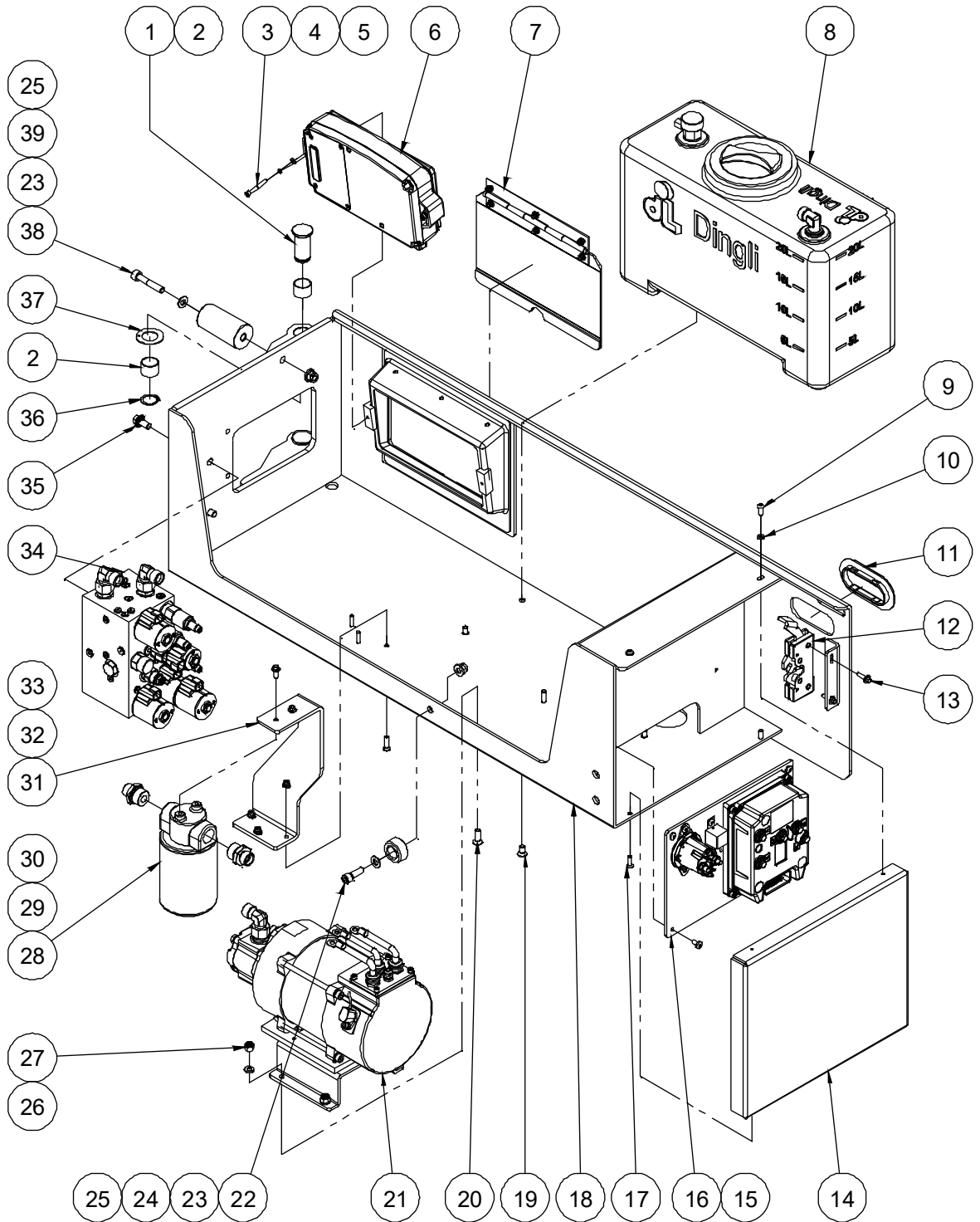

**105.1 Power Unit Module (Hydraulic Motor Drive)**

Item	Part No.	Description	Qty.
1	10000536	Hinge pin	2
2	00000368	8812-252820 Bearing	4
3	00002392	Screw GB/T 70.1 M5×40	2
4	00000606	Washer GB/T 93 5	2
5	00000605	Washer GB/T 97.1 5	2
6	00007543	Ground control assembly (without IOT module) (refer to 107.1)	1
	00006801	Ground control assembly (with IOT module) (refer to 107.1)	1
7		Ground control cover assembly (refer to 108.1)	1
8		Hydraulic tank assembly (refer to 109.1)	1
9	00001179	Screw GB/T 70.2 M6×16	2
10	00000620	Washer GB/T 97.1 6	6
11	10000540	Handle hole ring	1
12	10000480	Latch (right)	1
13	00002866	Bolt QC/T 340 M6×20	2
14	10000048	Cover	1
15	00001060	Screw GB/T 818 M6×12 - H	4
16		Motor controller assembly (refer to 110.1)	1
17	00000831	Screw GB/T 70.3 M6×20	2
18	10015302	Hydraulic tray weldment (JCPT0808HA, JCPT0812HA, JCPT1008HA, JCPT1012HA, JCPT1212HA, JCPT1412HA, JCPT1612HAS)	1
	10015317	Hydraulic tray weldment (JCPT1612HA, JCPT1614HA)	1
19	00000837	Screw GB/T 70.3 M8×16	4
20	00000838	Screw GB/T 70.3 M8×25	4
21		Pump motor assembly (refer to 111.1)	1
22	00001059	Screw GB/T 70.1 M10×30 (JCPT0812HA, JCPT1012HA, JCPT1212HA, JCPT1412HA, JCPT1612HAS)	1
	00002234	Screw GB/T 70.1 M10×55 (JCPT1612HA, JCPT1614HA)	1

**105.1 Power Unit Module (Hydraulic Motor Drive)**

Item	Part No.	Description	Qty.
23	00000615	Washer GB/T 97.1 10	1
24	10014558	Bumper (JCPT0812HA, JCPT1012HA, JCPT1212HA)	1
	10014559	Bumper (JCPT1412HA, JCPT1612HAS)	1
	10014560	Bumper (JCPT1612HA, JCPT1614HA)	1
25	00002572	Nut GB/T 6183.1 M10	2
26	00000608	Washer GB/T 97.1 8	4
27	00001163	Nut GB/T 6182 M8	4
28	00000535	Filter assembly	1
--	00003061	Filter element	1
29	00001508	Straight fitting	2
30	00002864	Bolt QC/T 340 M6×16	2
31	10013657	Filter bracket	1
32	00000832	Screw GB/T 70.3 M6×25	3
33	00002574	Nut GB/T 6183.1 M6	3
34		Function manifold (refer to 403.1)	1
35	00002873	Bolt QC/T 340 M10×20	2
36	00000992	Circlips GB/T 894.1-25	2
37	00000384	8832-26 Bearing	2
38	00002234	Screw GB/T 70.1 M10×55	1
39	10000539	Bumper	1

### 106.1 Power Unit Module (Electric Motor Drive)

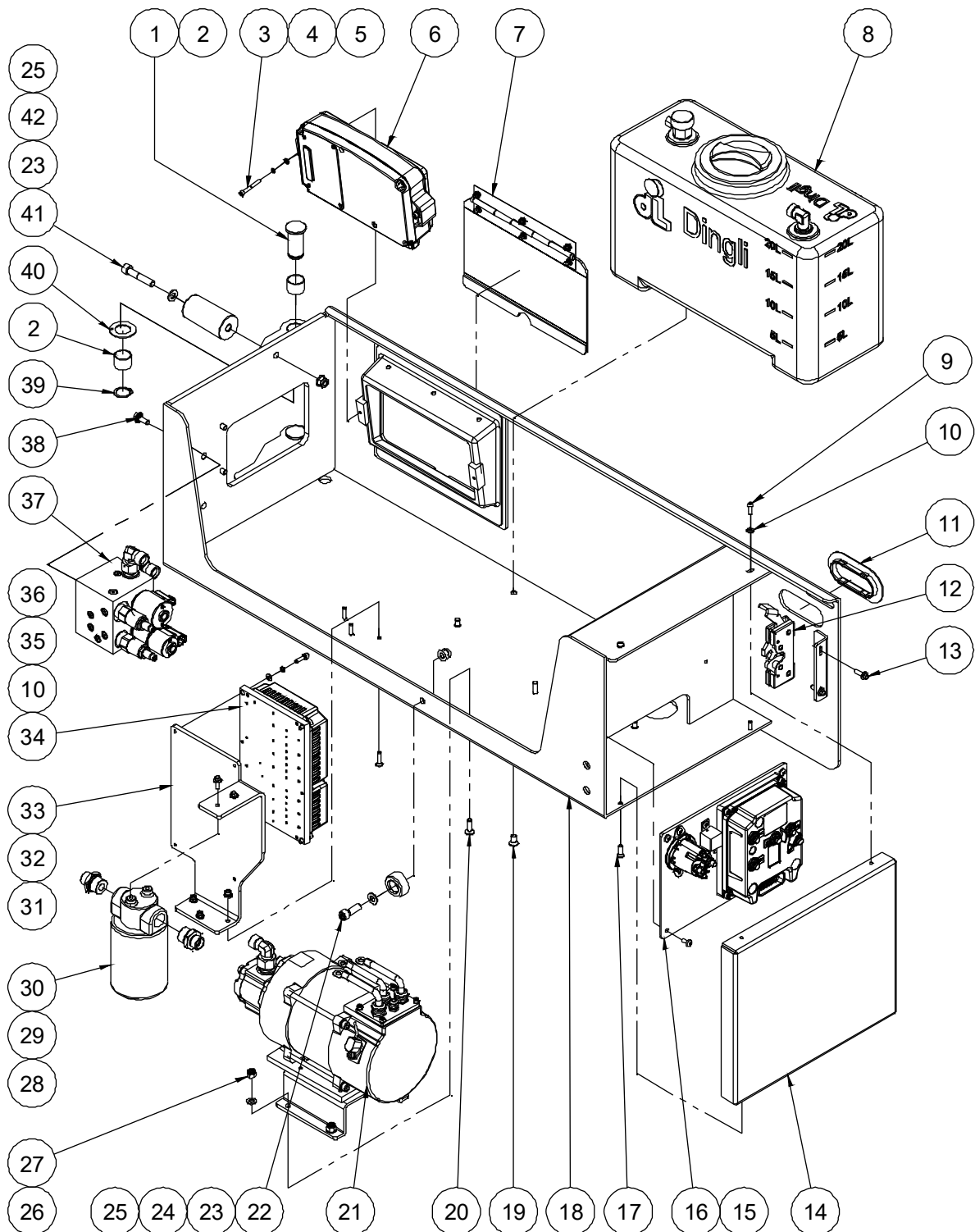

**106.1 Power Unit Module (Electric Motor Drive)**

Item	Part No.	Description	Qty.
1	10000536	Hinge pin	2
2	00000368	8812-252820 Bearing	4
3	00002392	Screw GB/T 70.1 M5×40	2
4	00000606	Washer GB/T 93 5	2
5	00000605	Washer GB/T 97.1 5	2
6	00007543	Ground control assembly (without IOT module) (refer to 107.1)	1
	00006801	Ground control assembly (with IOT module) (refer to 107.1)	1
7		Ground control cover assembly (refer to 108.1)	1
8		Hydraulic tank assembly (refer to 109.1)	1
9	00001179	Screw GB/T 70.2 M6×16	2
10	00000620	Washer GB/T 97.1 6	6
11	10000540	Handle hole ring	1
12	10000480	Latch (right)	1
13	00002866	Bolt QC/T 340 M6×20	2
14	10000048	Cover	1
15	00001060	Screw GB/T 818 M6×12 - H	4
16		Motor controller assembly (refer to 110.1)	1
17	00000831	Screw GB/T 70.3 M6×20	2
18	10015302	Hydraulic tray weldment (JCPT0808AC, JCPT0812AC, JCPT1008AC, JCPT1012AC, JCPT1212AC, JCPT1412AC, JCPT1612ACS)	1
	10015317	Hydraulic tray weldment (JCPT1612AC, JCPT1614AC)	1
19	00000837	Screw GB/T 70.3 M8×16	4
20	00000838	Screw GB/T 70.3 M8×25	4
21		Pump motor assembly (refer to 111.1)	1
22	00001059	Screw GB/T 70.1 M10×30 (JCPT0812AC, JCPT1012AC, JCPT1212AC, JCPT1412AC, JCPT1612ACS)	1
	00002234	Screw GB/T 70.1 M10×55 (JCPT1612AC, JCPT1614AC)	1

**106.1 Power Unit Module (Electric Motor Drive)**

Item	Part No.	Description	Qty.
23	00000615	Washer GB/T 97.1 10	1
24	10014558	Bumper (JCPT0812AC, JCPT1012AC, JCPT1212AC)	1
	10014559	Bumper (JCPT1412AC, JCPT1612ACS)	1
	10014560	Bumper (JCPT1612AC, JCPT1614AC)	1
25	00002572	Nut GB/T 6183.1 M10	1
26	00000608	Washer GB/T 97.1 8	4
27	00001163	Nut GB/T 6182 M8	4
28	00002864	Bolt QC/T 340 M6×16	2
29	00001508	Straight fitting	2
30	00000535	Filter assembly	1
--	00003061	Filter element	1
31	00002574	Nut GB/T 6183.1 M6	3
32	00000832	Screw GB/T 70.3 M6×25	3
33	10012199	Controller bracket	1
34	00006262	Motor controller	1
35	00000621	Washer GB/T 93 6	4
36	00000774	Screw GB/T 70.1 M6×20	4
37		Function manifold (refer to 404.1)	1
38	00002875	Bolt QC/T 340 M8×20	4
39	00000992	Circlips GB/T 894.1-25	2
40	00000384	8832-26 Bearing	2
41	00002234	Screw GB/T 70.1 M10×55	1
42	10000539	Bumper	1

**107.1 Ground Control Assembly**

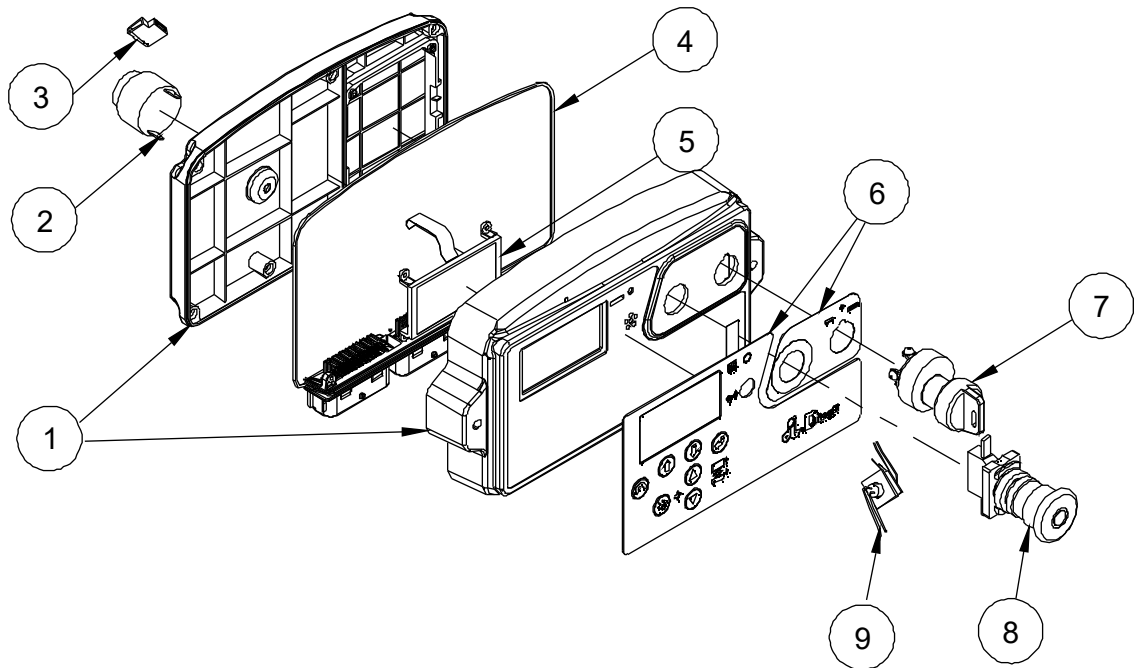

**107.1 Ground Control Assembly**

Item	Part No.	Description	Qty.
1	00008653	Shell components (without IOT module)	1
	00008654	Shell components (with IOT module )	1
2	00000712	Alarm	1
--	00003044	Alarm nut	1
3	00008656	Alarm Harness	1
4	00008659	Main Board	1
5	00008655	Display	1
6	00008658	Decal, Ground control panel	1
7	00001243	Key switch	1
--	00003050	Key	1
8	00000713	Emergency stop switch	1
--	00003045	Red mushroom head	1
--	00003046	Base with 1 NO contact	1
9	00008657	EMS Switch Harness	1

### 108.1 Ground Control Cover Assembly

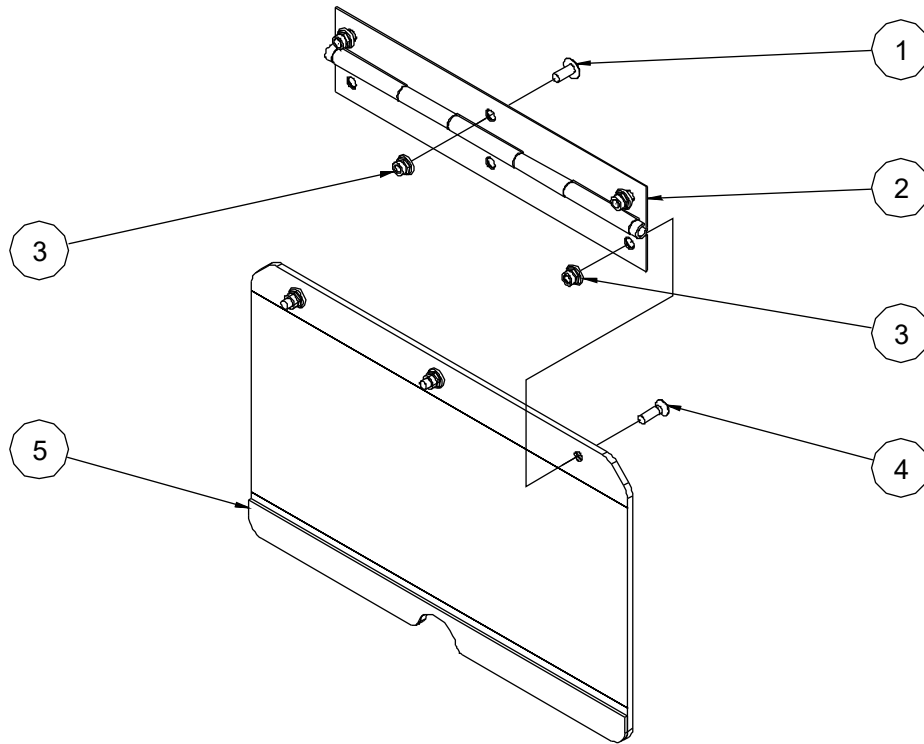

### 108.1 Ground Control Cover Assembly

Item	Part No.	Description	Qty.
1	00001011	Screw GB/T 973 M5×12	3
2	10013191	Hinge	1
3	00002573	Nut GB/T 6183.1 M5	6
4	00002337	Screw GB/T 819 M5×12 - H	3
5	10015360	Cover	1

### 109.1 Hydraulic Tank Assembly

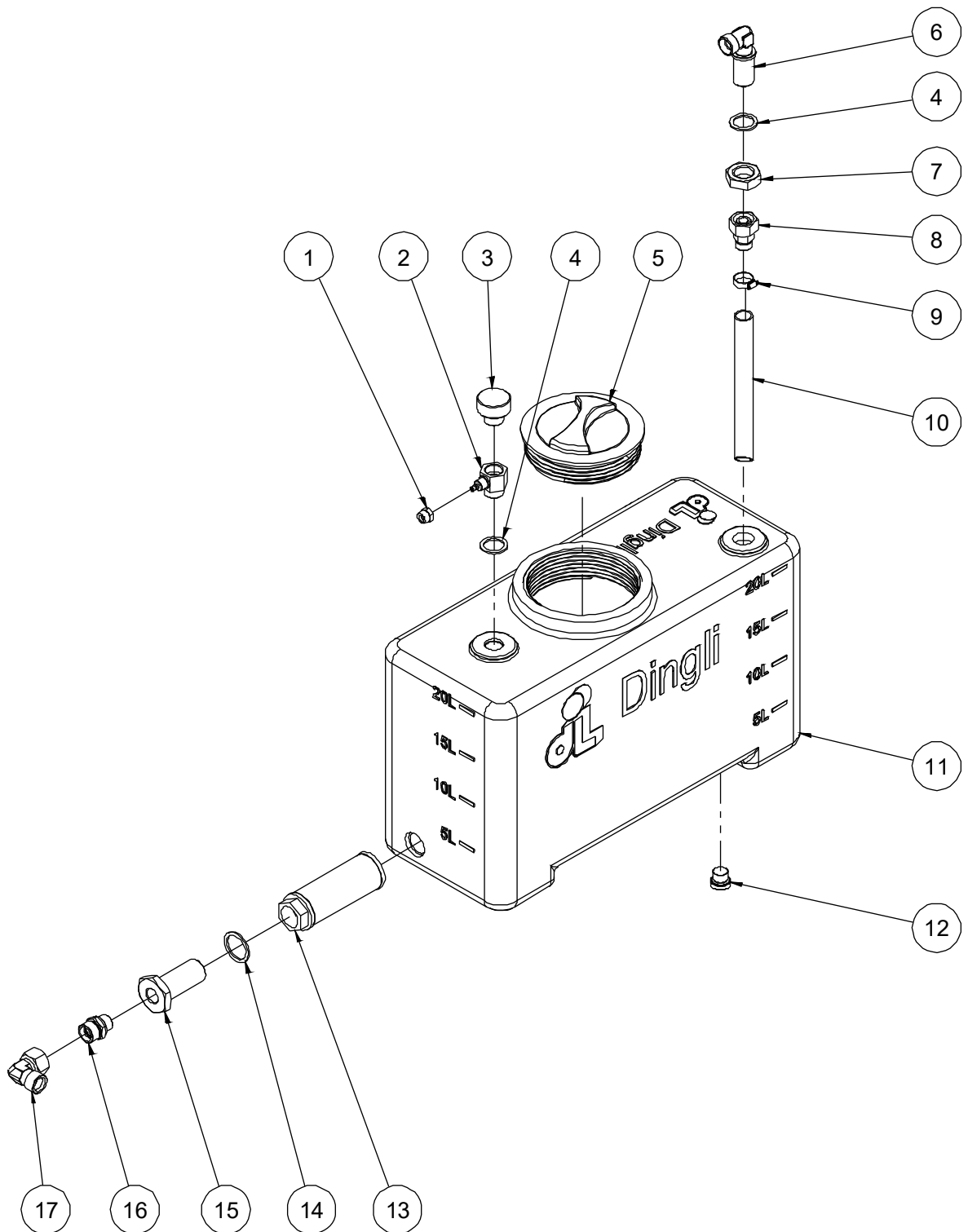

**109.1 Hydraulic Tank Assembly**

Item	Part No.	Description	Qty.
1	10000462	Nut	1
2	10000463	Fitting	1
3	10000398	Breather	1
4	00001338	Washer JB/T 982 22	2
5	10000453	Tank cover	1
6	10000466	Fitting	1
7	00001998	Nut GB/T 6173 M22×1.5	1
8	00003843	Straight fitting	1
9	00004605	Clamp	1
10	10005013	Hose	1
11	10000454	Tank	1
12	00001113	Plug VST13/8ED	1
13	00000541	Filter	1
14	10000455	Seal washer 27	1
15	10000456	Fitting	1
16	00001268	Straight fitting	1
17	00006447	Elbow	1

**110.1 Motor Controller Assembly**

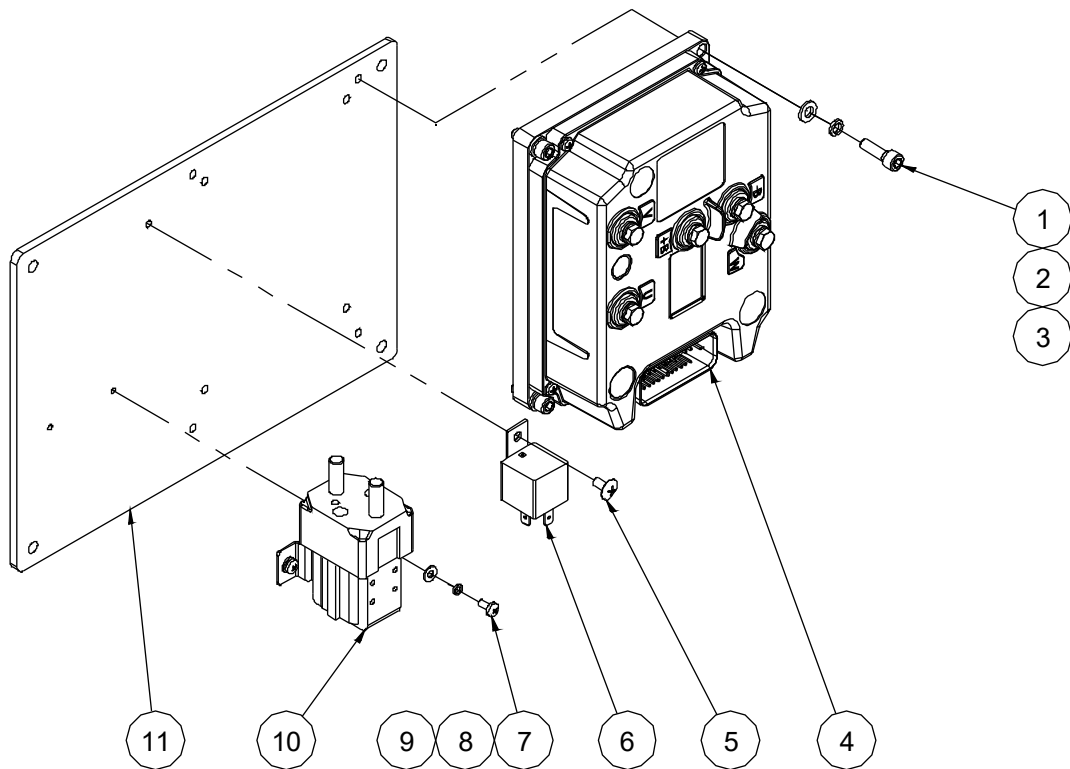

**110.1 Motor Controller Assembly**

Item	Part No.	Description	Qty.
1	00000774	Screw GB/T 70.1 M6×20	4
2	00000621	Washer GB/T 93 6	4
3	00000620	Washer GB/T 97.1 6	4
4	00006263	Motor controller	1
5	00000999	Screw GB/T 973 M5×10	1
6	00007491	Relay	1
7	00002333	Screw GB/T 818 M4×8 - H	2
8	00000779	Washer GB/T 93 4	2
9	00000778	Washer GB/T 97.1 4	2
10	00002028	Contactor	1
11	10015305	Mounting plate	1

**111.1 Pump Motor Assembly**

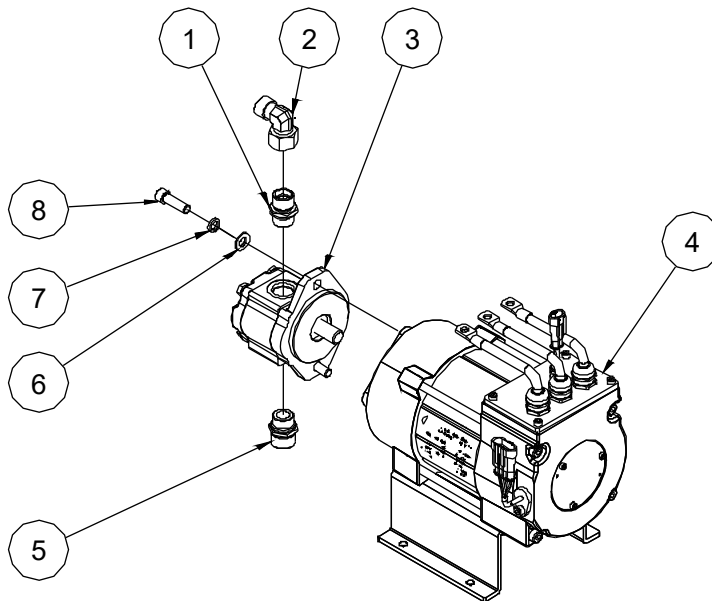

**111.1 Pump Motor Assembly**

Item	Part No.	Description	Qty.
1	00001776	Straight fitting	1
2	00001835	Elbow	1
3	00000529	Pump	1
4	00008010	Motor	1
5	00001778	Straight fitting	1
6	00000615	Washer GB/T 97.1 10	2
7	00000679	Washer GB/T 93 10	2
8	00001157	3/8-24×1 1/4" Screw ANSI B18.3	2

112.1 Rear Wheel and Ladder (Hydraulic Motor Drive)

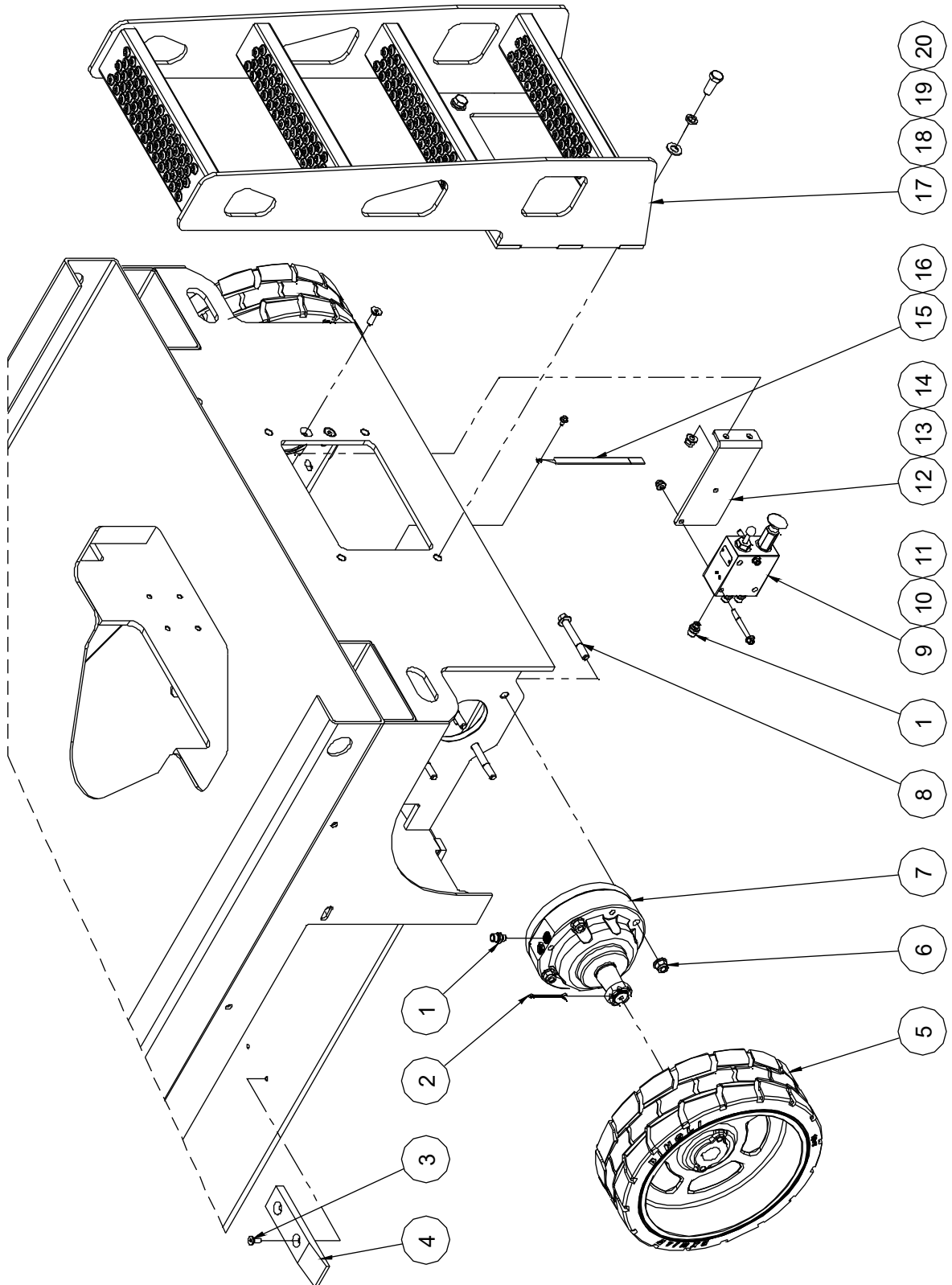

**112.1 Rear Wheel and Ladder (Hydraulic Motor Drive)**

Item	Part No.	Description	Qty.
1	00001769	Straight fitting	5
2	00005279	Cotter pin GB/T 91 4×70	2
3	00000765	Screw GB/T 70.3 M8×20	4
4	10000484	Spacer	2
5	10000486	Wheel	2
6	00002576	Nut GB/T 6183.1 M12	8
7	00002010	Brake (JCPT0808HA, JCPT0812HA, JCPT1008HA, JCPT1012HA)	2
	00000534	Brake (JCPT1212HA, JCPT1412HA, JCPT1612HA, JCPT1612HAS, JCPT1614HA)	2
8	00002882	Bolt GB/T 16674 M12×90	8
9	00000530	Brake release hand pump manifold	1
10	00002608	Bolt GB/T 16674 M8×70	2
11	00002575	Nut GB/T 6183.1 M8	2
12	10000033	Mounting bracket	1
13	00002572	Nut GB/T 6183.1 M10	2
14	00000847	Screw GB/T 70.3 M10×30	2
15	10000487	Ground strap	1
16	00002863	Bolt QC/T 340 M6×10	1
17	10000679	Ladder(without circuit breaker bracket) (JCPT0808HA-CE, JCPT0812HA-CE, JCPT1008HA-CE, JCPT1012HA-CE, JCPT0812HA-ANSI, JCPT1008HA-ANSI, JCPT1012HA-ANSI)	1
	10000619	Ladder(without circuit breaker bracket) (JCPT1212HA-CE, JCPT1412HA-CE, JCPT1612HA-CE, JCPT1612HAS-CE, JCPT1412HA-ANSI, JCPT1614HA-ANSI)	1
	10000681	Ladder (without circuit breaker bracket) (JCPT0808HA -ANSI)	1
	10000817	Ladder (without circuit breaker bracket) (JCPT1212HA -ANSI)	1
	10001805	Ladder (with circuit breaker bracket) (JCPT0808HA-CE, JCPT0812HA-CE, JCPT1008HA-CE, JCPT1012HA-CE)	1
	10001638	Ladder (with circuit breaker bracket) (JCPT1212HA-CE, JCPT1412HA-CE, JCPT1612HA-CE, JCPT1612HAS-CE)	1

**112.1 Rear Wheel and Ladder (Hydraulic Motor Drive)**

<b>Item</b>	<b>Part No.</b>	<b>Description</b>	<b>Qty.</b>
18	00001043	Washer GB/T 97.1 14	4
19	00001258	Washer GB/T 93 14	4
20	00002248	Bolt GB/T 5783 M14×35	4

### 113.1 Rear Wheel and Ladder (Electric Motor Drive)

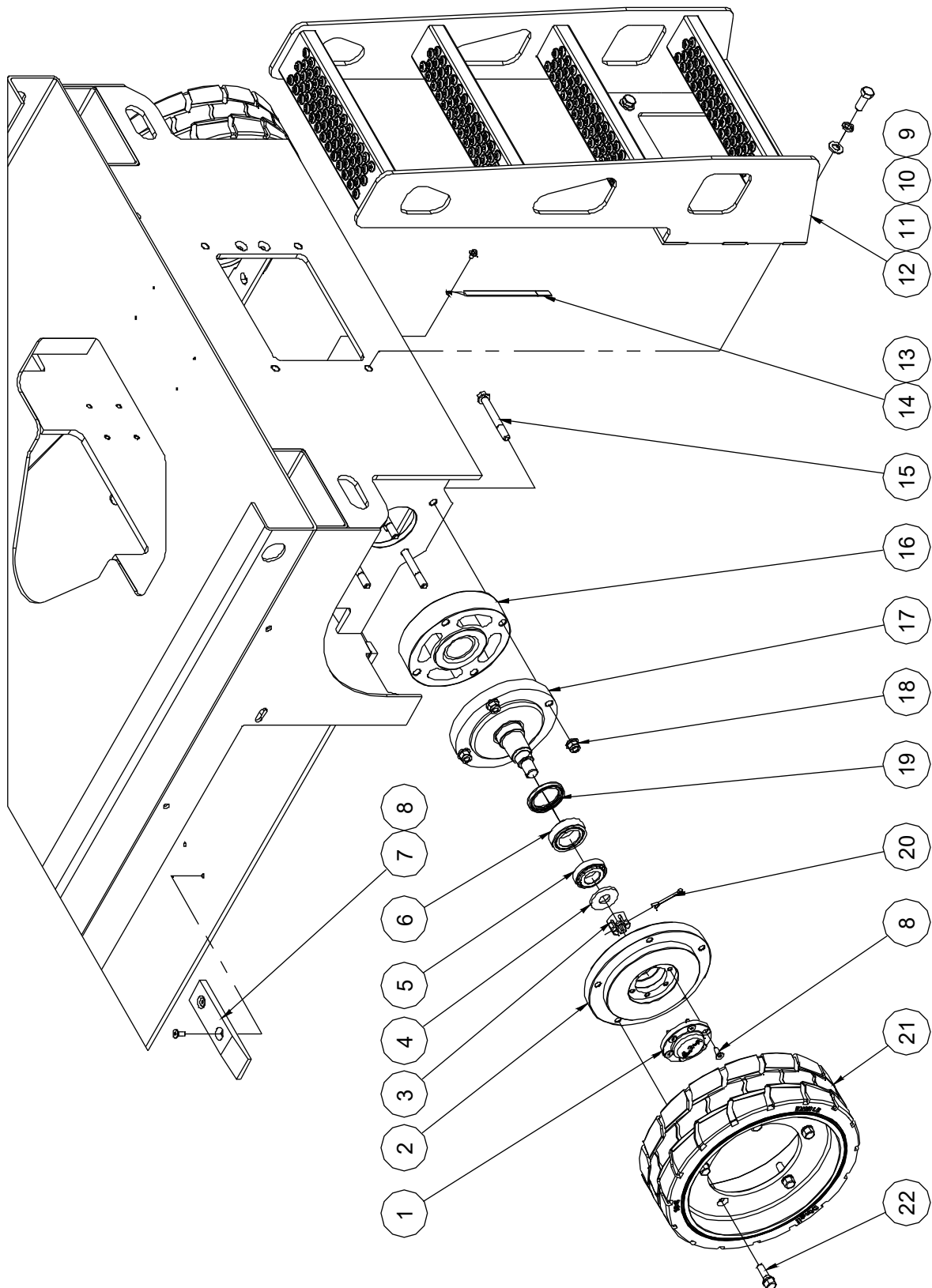

**113.1 Rear Wheel and Ladder (Electric Motor Drive)**

Item	Part No.	Description	Qty.
--	10014970	Rear wheel assembly (includes Item 1-6 and 15-22)	/
1	10000638	Cap	2
2	10000639	Bearing seat	2
3	00001884	Nut GB/T 9459 M22×1.5	2
4	10000637	Washer	2
5	00001129	Bearing 30206 GB/T 297	2
6	00001971	Bearing 33008 GB/T 297	2
7	10000484	Spacer	2
8	00000765	Screw GB/T 70.3 M8×20	16
9	00002248	Bolt GB/T 5783 M14×35	4
10	00001258	Washer GB/T 93 14	4
11	00001043	Washer GB/T 97.1 14	4
12	10000679	Ladder (without circuit breaker bracket) (JCPT0808AC-CE, JCPT0812AC-CE, JCPT1008AC-CE, JCPT1012AC-CE, JCPT0812AC-ANSI, JCPT1008AC-ANSI, JCPT1012AC-ANSI)	1
	10000619	Ladder (without circuit breaker bracket) (JCPT1212AC-CE, JCPT1412AC-CE, JCPT1612AC-CE, JCPT1612ACS-CE, JCPT1412AC-ANSI, JCPT1614AC-ANSI)	1
	10000681	Ladder (without circuit breaker bracket) (JCPT0808AC-ANSI)	1
	10000817	Ladder (without circuit breaker bracket) (JCPT1212AC-ANSI)	1
	10001805	Ladder (with circuit breaker bracket) (JCPT0808AC-CE, JCPT0812AC-CE, JCPT1008AC-CE, JCPT1012AC-CE)	1
	10001638	Ladder (with circuit breaker bracket) (JCPT1212AC-CE, JCPT1412AC-CE, JCPT1612AC-CE, JCPT1612ACS-CE)	1
13	00002863	Bolt QC/T 340 M6×10	1
14	10000487	Ground strap	1
15	00002885	Bolt GB/T 16674 M12×100	8
16	10000640	Terminal pad	2
17	10000642	Spindle	2
18	00002576	Nut GB/T 6183.1 M12	8

**113.1 Rear Wheel and Ladder (Electric Motor Drive)**

<b>Item</b>	<b>Part No.</b>	<b>Description</b>	<b>Qty.</b>
19	00002081	Seal GB/T 13871.1 FB 50 70 8 III	2
20	00005416	Cotter pin GB/T 91 5×50	2
21	10014972	Wheel	2
22	10014971	Bolt	10

### 114.1 Chassis Accessory Installation

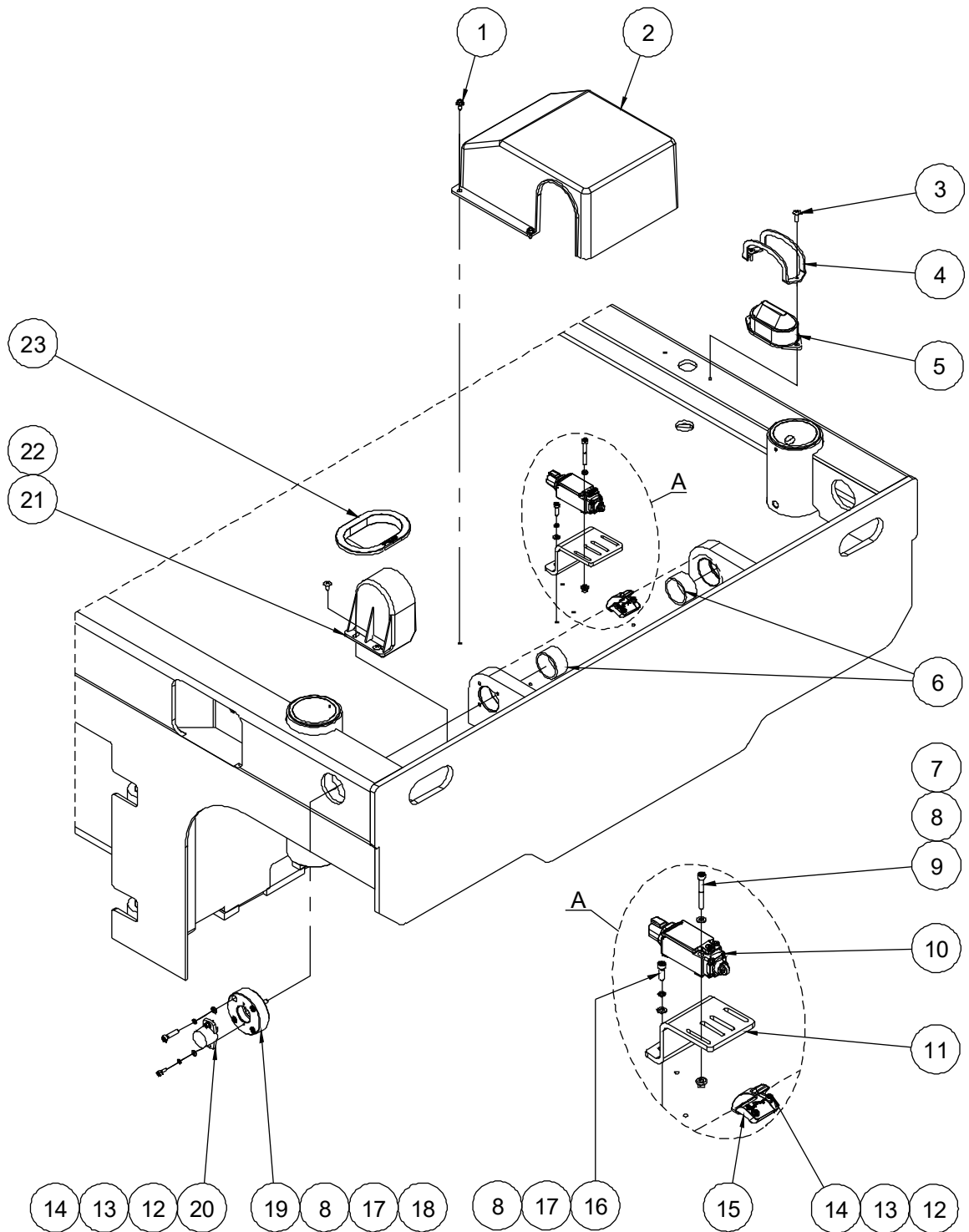

**114.1 Chassis Accessory Installation**

Item	Part No.	Description	Qty.
1	00004298	Screw GB/T 5789 M5×10	6
2	10016545	Cover	1
3	00002523	Screw GB/T 973 M5×16	2
4	10000488	Beacon cover	1
5	00000740	Beacon	1
6	00004736	8813-38.1×44.45×22 Bearing	2
7	00002573	Nut GB/T 6183.1 M5	2
8	00000605	Washer GB/T 97.1 5	8
9	00002392	Screw GB/T 70.1 M5×40	2
10	00007932	Limit switch	1
11	10000631	Switch bracket	1
12	00000778	Washer GB/T 97.1 4	4
13	00000779	Washer GB/T 93 4	4
14	00001054	Screw GB/T 70.1 M4×12	4
15	10000630	Signal plate	1
16	00001246	Screw GB/T 70.1 M5×16	2
17	00000606	Washer GB/T 93 5	6
18	00002484	Screw GB/T 70.1 M5×25	4
19	10002372	Sensor bracket	1
20	00004796	Rotary sensor	1
21	10018267	Sensor cover	1
22	00000999	Screw GB/T 973 M5×10	2
23	10000039	Sheath	1

### 115.1 Counterweight

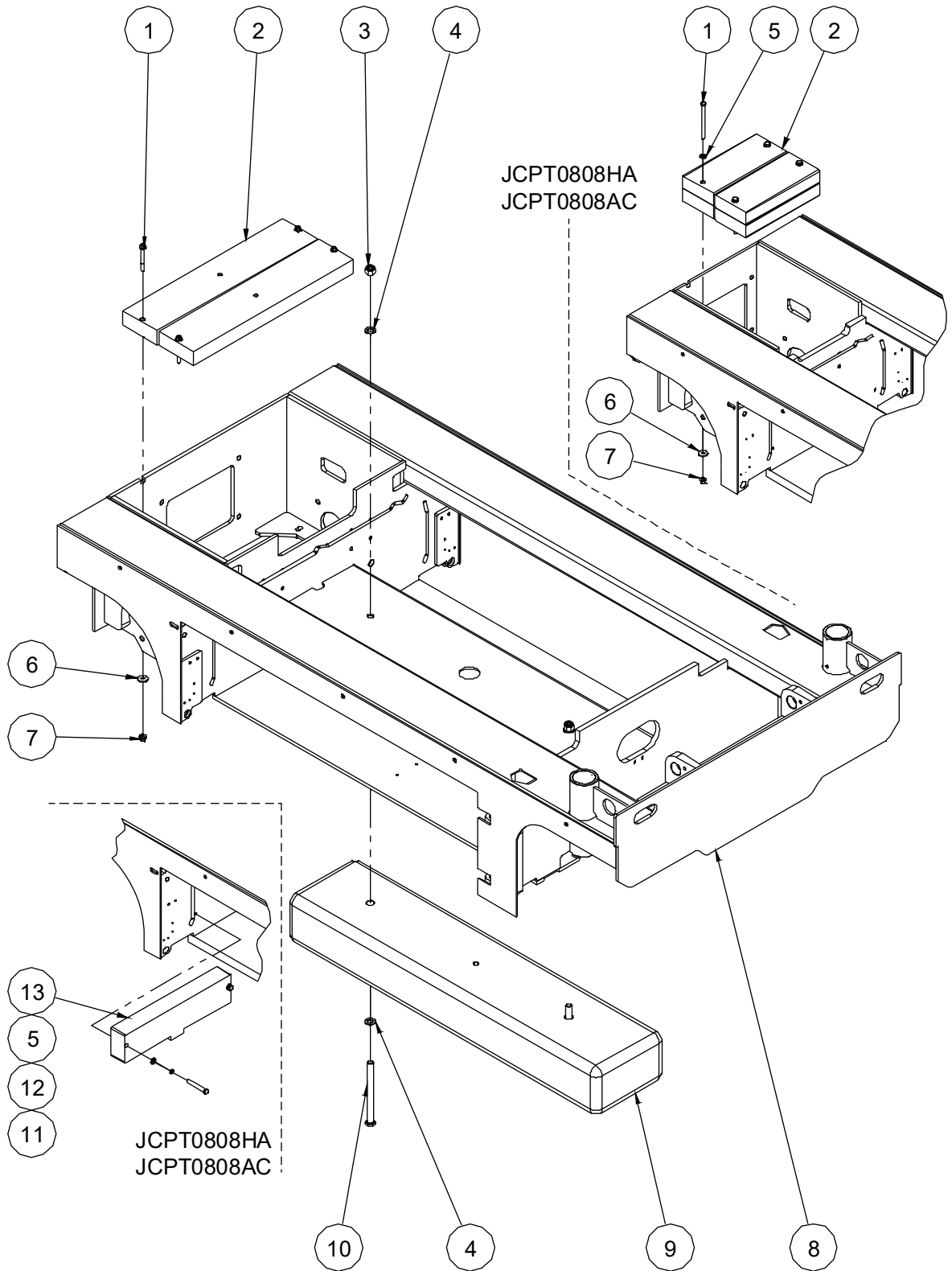

**115.1 Counterweight**

Item	Part No.	Description	Qty.
1	00006082	Bolt GB/T 5782 M10×130 (JCPT0808HA/AC-CE)	4
	00002883	Bolt GB/T 16674 M10×80 (JCPT1212HA-CE)	4
	00002883	Bolt GB/T 16674 M10×80 (JCPT1212HA-ANSI, JCPT1212AC-CE)	2
2	10000011	Counterweight 18 (JCPT0808HA/AC-CE)	4
	10000489	Counterweight 35 (JCPT1212HA-CE)	2
	10000489	Counterweight 35 (JCPT1212HA-ANSI, JCPT1212AC-CE)	1
3	00001257	Nut GB/T 6182 M16 (JCPT1012HA/AC-CE, JCPT1212HA/AC-CE, JCPT1412HA/AC-CE&ANSI)	2
4	00000997	Washer GB/T 97.1 16 (JCPT1012HA/AC-CE, JCPT1212HA/AC-CE, JCPT1412HA/AC-CE&ANSI)	4
5	00000615	Washer GB/T 97.1 10 (JCPT0808HA/AC-CE)	6
6	00001028	Washer GB/T 96.1 10 (JCPT0808HA/AC-CE, JCPT1212HA-CE)	4
	00001028	Washer GB/T 96.1 10 (JCPT1212HA-ANSI, JCPT1212AC-CE)	2
7	00002572	Nut GB/T 6183.1 M10 (JCPT0808HA/AC-CE, JCPT1212HA-CE)	4
	00002572	Nut GB/T 6183.1 M10 (JCPT1212HA-ANSI, JCPT1212AC-CE)	2
8	10016046	Frame weldment (JCPT0808HA/AC, JCPT1008HA/AC)	1
	10018713	Frame weldment (JCPT0812HA/AC)	
	10016041	Frame weldment (JCPT1012HA/AC, JCPT1212HA/AC)	1
	10016420	Frame weldment (JCPT1412HA/AC, JCPT1612HAS/ACS)	1
	10016423	Frame weldment (JCPT1612HA/AC)	1
	10015442	Frame weldment (JCPT1614HA/AC)	1
9	10000483	Counterweight 400 (JCPT1012HA/AC-CE, JCPT1212HA/AC-CE)	1
	10016533	Counterweight 400 (JCPT1412HA/AC-ANSI)	1
	10000777	Counterweight 180 (JCPT1412HA/AC-CE, JCPT1612HAS/ACS-CE)	1
10	00005281	Bolt GB/T 5782 M16×210 (JCPT1012HA/AC-CE, JCPT1212HA/AC-CE, JCPT1412HA/AC-CE&ANSI, JCPT1612HAS/ACS-CE)	2
11	00001027	Bolt GB/T 5782 M10×80 (JCPT0808HA/AC-CE)	2

**115.1 Counterweight**

<b>Item</b>	<b>Part No.</b>	<b>Description</b>	<b>Qty.</b>
12	00000679	Washer GB/T 93 10 (JCPT0808HA/AC-CE)	2
13	10000061	Counterweight 28 (JCPT0808HA/AC-CE)	1

# **Section 2 Scissor**

201.1 Scissor Assembly (JCPT0808HA/AC)

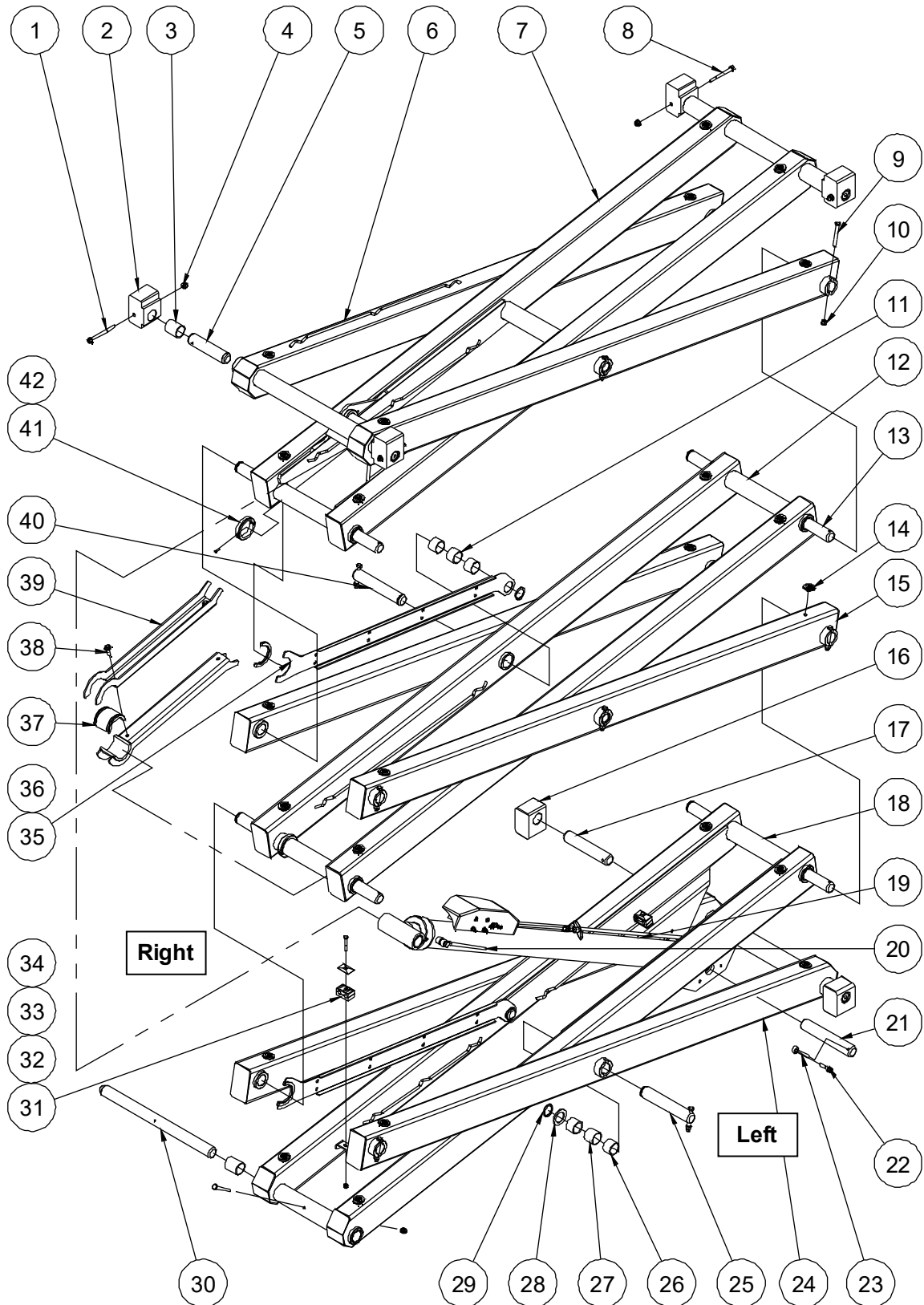

**201.1 Scissor Assembly (JCPT0808HA/AC)**

Item	Part No.	Description	Qty.
1	00002891	Bolt GB/T 16674 M10×110	2
2	10000252	Platform slider	4
3	00000439	8813-38.1×44.45×50.8 Bearing	6
4	00002572	Nut GB/T 6183.1 M10	7
5	00002098	896B-38.1×146 Pin	4
6	10000605	Outer arm 3	1
7	10000603	Inner arm 3	1
8	00002884	Bolt GB/T 16674 M10×100	2
9	00001027	Bolt GB/T 5782 M10×80	12
10	00000623	Nut GB/T 6182 M10	12
11	10000256	Spacer sleeve	2
12	10014451	Inner arm 2	1
13	00000568	898-38.1×638.5 Pin	5
14	10000264	Block	24
15	10000285	Outer arm	1
--	10014904	Left single link	1
--	10014903	Right single link	1
16	10000255	Chassis slider	2
17	00000598	895B-38.1×185 Pin	2
18	10019581	Inner arm 1	1
19		Lower lift cylinder assembly (without seal kit) (refer to 401.1)	1
20	10001170	Hose (to tank)	1
21	00000595	895-38.1×220 Pin	2
22	00005413	Bolt GB/T 16674 M10×40	1
23	00000220	8902-10080 Pin	2
24	10000601	Outer arm 1	1
25	00000566	898-38.1×206.5 Pin	2
26	00000438	8813-38.1×44.45×31.75 Bearing	18

**201.1 Scissor Assembly (JCPT0808HA/AC)**

Item	Part No.	Description	Qty.
27	10000257	Spacer sleeve	2
28	10000254	Washer	6
29	00000787	Circlips JB/ZQ 4342-38	9
30	10002371	Pin	1
31	00008962	Hose clamp	2
32	10000047	Base plate	2
33	00002575	Nut GB/T 6183.1 M8	2
34	00002089	Bolt GB/T 5782 M8×50	2
35	10014454	Cable bridge	2
36	10011771	Clamp	2
37	10000260	Safety arm bushing	2
38	00005263	Bolt QC/T 340 M10×30	3
39	10000259	Safety arm	2
40	00000565	898-38.1×199.5 Pin	2
41	10011770	Collar	2
42	00000822	Screw GB/T 70.3 M5×16	2

202.1 Scissor Assembly (JCPT0812HA/AC)

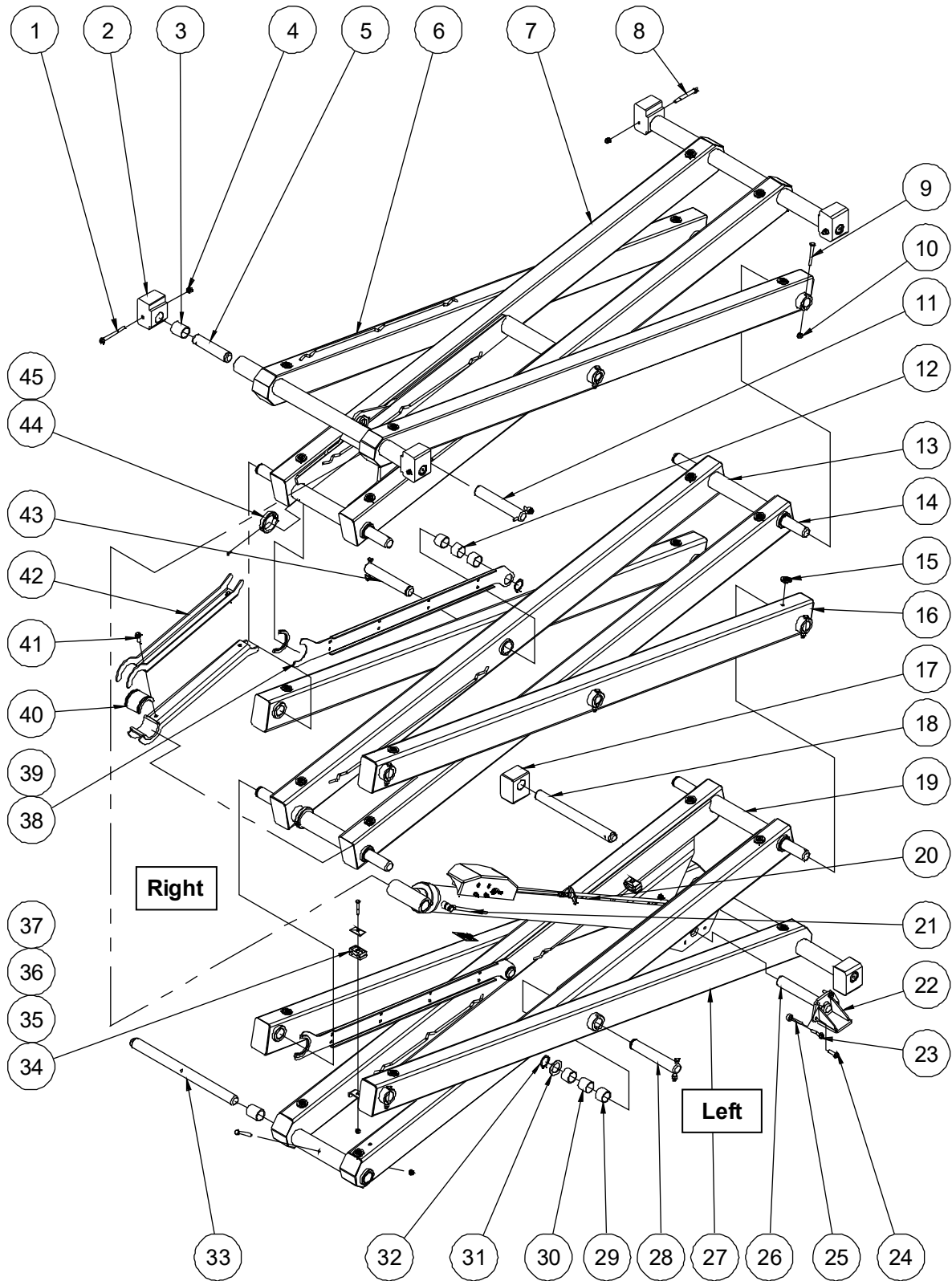

**202.1 Scissor Assembly (JCPT0812HA/AC)**

Item	Part No.	Description	Qty.
1	00002891	Bolt GB/T 16674 M10×110	2
2	10000252	Platform slider	4
3	00000439	8813-38.1×44.45×50.8 Bearing	6
4	00002572	Nut GB/T 6183.1 M10	14
5	00002098	896B-38.1×146 Pin	4
6	10000293	Outer arm 5	1
7	10015431	Inner arm 3	1
8	00002884	Bolt GB/T 16674 M10×100	2
9	00001027	Bolt GB/T 5782 M10×80	12
10	00000623	Nut GB/T 6182 M10	12
11	00000595	895-38.1×220 Pin	1
12	10000256	Spacer sleeve	2
13	10014451	Inner arm 2	1
14	00000568	898-38.1×638.5 Pin	5
15	10000264	Block	24
16	10000285	Outer arm	1
--	10014904	Left single link	1
--	10014903	Right single link	1
17	10000255	Chassis slider	2
18	00002096	896B-38.1×25A Pin	2
19	10019581	Inner arm 1	1
20		Lower lift cylinder assembly (without seal kit) (refer to 401.1)	1
21	10001170	Hose (to tank)	1
22	10000265	Pothole pusher	2
23	00005412	Bolt GB/T 16674 M10×45	1
24	00002877	Bolt QC/T 340 M10×35	7
25	00000220	8902-10080 Pin	2
26	00000596	895-38.1×236 Pin	1

**202.1 Scissor Assembly (JCPT0812HA/AC)**

Item	Part No.	Description	Qty.
28	00000566	898-38.1×206.5 Pin	2
29	00000438	8813-38.1×44.45×31.75 Bearing	18
30	10000257	Spacer sleeve	2
31	10000254	Washer	6
32	00000787	Circlips JB/ZQ 4342-38	9
33	10002371	Pin	1
34	00008962	Hose clamp	2
35	10000047	Base plate	2
36	00002575	Nut GB/T 6183.1 M8	2
37	00002089	Bolt GB/T 5782 M8×50	2
38	10014454	Cable bridge	2
39	10011771	Clamp	2
40	10000260	Safety arm bushing	2
41	00005263	Bolt QC/T 340 M10×30	3
42	10000259	Safety arm	2
43	00000565	898-38.1×199.5 Pin	2
44	10011770	Collar	2
45	00000822	Screw GB/T 70.3 M5×16	2

203.1 Scissor Assembly (JCPT1008HA/AC)

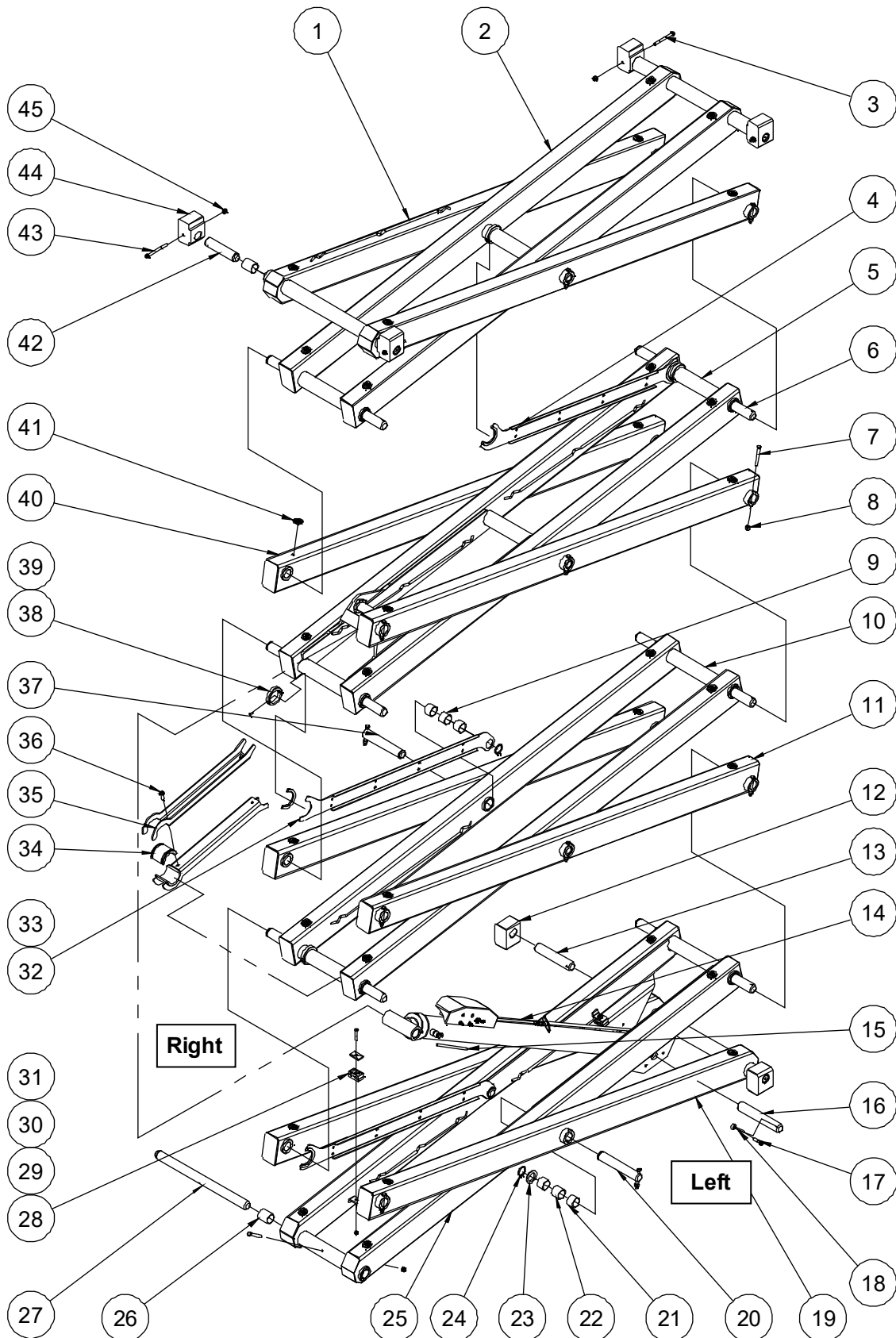

**203.1 Scissor Assembly (JCPT1008HA/AC)**

Item	Part No.	Description	Qty.
1	10000605	Outer arm 3	1
2	10000737	Inner arm 4	1
3	00002884	Bolt GB/T 16674 M10×100	2
4	10000044	Cable bridge	1
5	10000735	Inner arm 3	1
6	00000568	898-38.1×638.5 Pin	8
7	00001027	Bolt GB/T 5782 M10×80	15
8	00000623	Nut GB/T 6182 M10	15
9	10000256	Spacer sleeve	2
10	10014451	Inner arm 2	1
11	10000285	Outer arm	1
--	10014904	Left single link	1
--	10014903	Right single link	1
12	10000255	Chassis slider	2
13	00000598	895B-38.1×185 Pin	2
14		Lower lift cylinder assembly (without seal kit) (refer to 401.1)	1
15	10001170	Hose (to tank)	1
16	00000595	895-38.1×220 Pin	2
17	00005413	Bolt GB/T 16674 M10×40	1
18	00000220	8902-10080 Pin	2
19	10000601	Outer arm 1	1
20	00000566	898-38.1×206.5 Pin	2
21	00000438	8813-38.1×44.45×31.75 Bearing	24
22	10000257	Spacer sleeve	2
23	10000254	Washer	10
24	00000787	Circlips JB/ZQ 4342-38	12
25	10019581	Inner arm 1	1
26	00000439	8813-38.1×44.45×50.8 Bearing	6

**203.1 Scissor Assembly (JCPT1008HA/AC)**

Item	Part No.	Description	Qty.
27	10002371	Pin	1
28	00008962	Hose clamp	2
29	10000047	Base plate	2
30	00002575	Nut GB/T 6183.1 M8	2
31	00002089	Bolt GB/T 5782 M8×50	2
32	10014454	Cable bridge	2
33	10011771	Clamp	4
34	10000260	Safety arm bushing	2
35	10000259	Safety arm	2
36	00005263	Bolt QC/T 340 M10×30	3
37	00000565	898-38.1×199.5 Pin	2
38	10011770	Collar	4
39	00000822	Screw GB/T 70.3 M5×16	4
40	10000736	Outer arm 3	1
--	10014904	Left single link	1
--	10014908	Right single link 5	1
41	10000264	Block	32
42	00002098	896B-38.1×146 Pin	4
43	00002891	Bolt GB/T 16674 M10×110	2
44	10000252	Platform slider	4
45	00002572	Nut GB/T 6183.1 M10	7

### 204.1 Scissor Assembly (JCPT1012HA/AC)

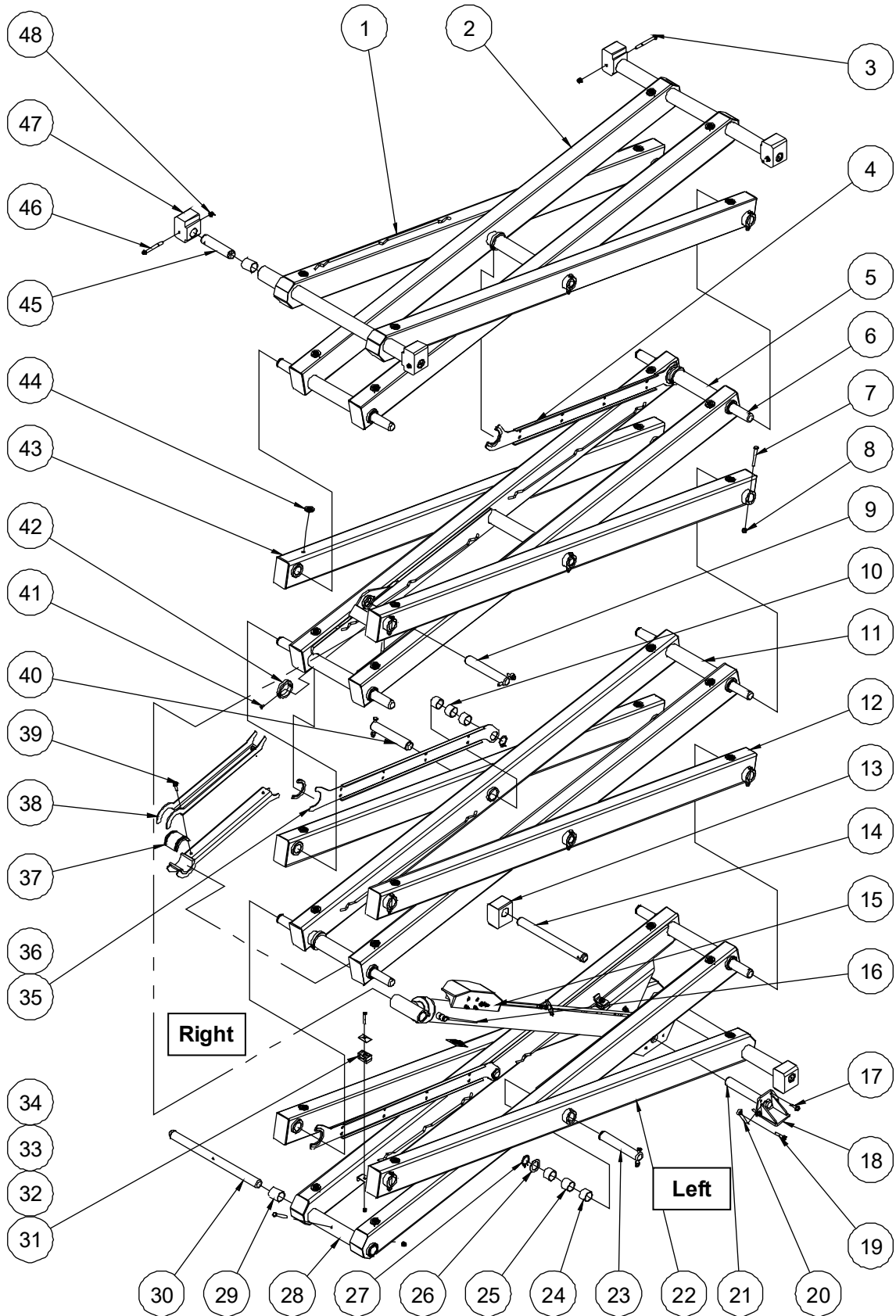

**204.1 Scissor Assembly (JCPT1012HA/AC)**

Item	Part No.	Description	Qty.
1	10000293	Outer arm 5	1
2	10000739	Inner arm 4	1
3	00002891	Bolt GB/T 16674 M10×110	2
4	10000044	Cable bridge	1
5	10000735	Inner arm 3	1
6	00000568	898-38.1×638.5 Pin	8
7	00001027	Bolt GB/T 5782 M10×80	15
8	00000623	Nut GB/T 6182 M10	15
9	00000595	895-38.1×220 Pin	1
10	10000256	Spacer sleeve	2
11	10014451	Inner arm 2	1
12	10000285	Outer arm	1
--	10014904	Left single link	1
--	10014903	Right single link	1
13	10000255	Chassis slider	2
14	00002096	896B-38.1×25A Pin	2
15		Lower lift cylinder assembly (without seal kit) (refer to 401.1)	1
16	10001170	Hose (to tank)	1
17	00002877	Bolt QC/T 340 M10×35	7
18	10000265	Pothole pusher	2
19	00005412	Bolt GB/T 16674 M10×45	1
20	00000220	8902-10080 Pin	2
21	00000596	895-38.1×236 Pin	1
22	10000278	Outer arm 1	1
23	00000566	898-38.1×206.5 Pin	2
24	00000438	8813-38.1×44.45×31.75 Bearing	24
25	10000257	Spacer sleeve	2
26	10000254	Washer	10

**204.1 Scissor Assembly (JCPT1012HA/AC)**

Item	Part No.	Description	Qty.
27	00000787	Circlips JB/ZQ 4342-38	12
28	10019581	Inner arm 1	1
29	00000439	8813-38.1×44.45×50.8 Bearing	6
30	10002371	Pin	1
31	00008962	Hose clamp	2
32	10000047	Base plate	2
33	00002575	Nut GB/T 6183.1 M8	2
34	00002089	Bolt GB/T 5782 M8×50	2
35	10014454	Cable bridge	2
36	10011771	Clamp	4
37	10000260	Safety arm bushing	2
38	10000259	Safety arm	2
39	00005263	Bolt QC/T 340 M10×30	3
40	00000565	898-38.1×199.5 Pin	2
41	00000822	Screw GB/T 70.3 M5×16	4
42	10011770	Collar	4
43	10000736	Outer arm 3	1
--	10014904	Left single link	1
--	10014908	Right single link 5	1
44	10000264	Block	32
45	00002098	896B-38.1×146 Pin	4
46	00002884	Bolt GB/T 16674 M10×100	2
47	10000252	Platform slider	4
48	00002572	Nut GB/T 6183.1 M10	14

**205.1 Scissor Assembly (JCPT1212HA/AC)**

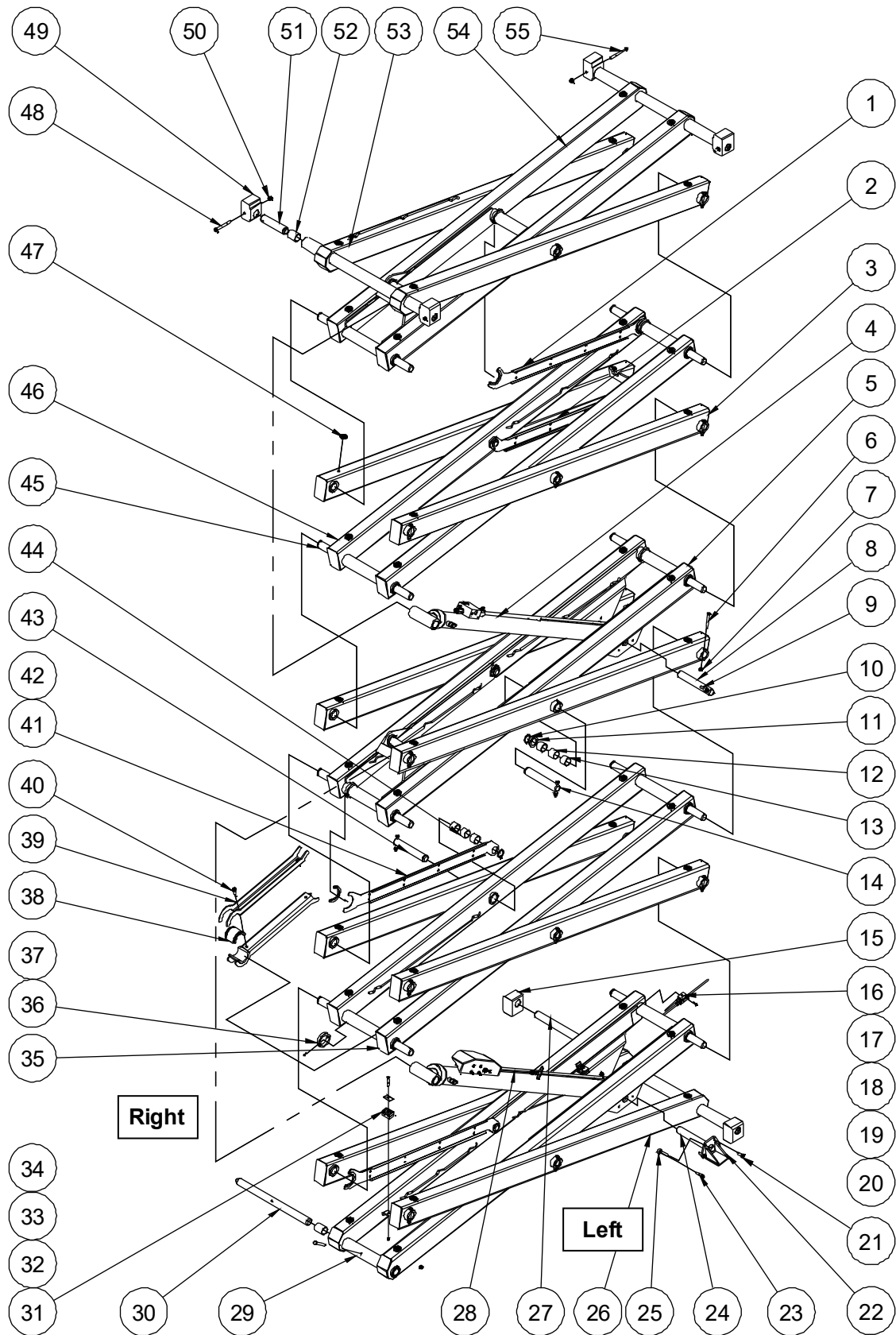

**205.1 Scissor Assembly (JCPT1212HA/AC)**

Item	Part No.	Description	Qty.
1	10000044	Cable bridge	1
2	10000261	Cable bridge	1
3	10000285	Outer arm	3
--	10014904	Left single link	1
--	10014903	Right single link	1
4		Upper lift cylinder assembly (without seal kit) (refer to 402.1)	1
5	10000286	Inner arm 3	1
6	00001027	Bolt GB/T 5782 M10×80	20
7	00000623	Nut GB/T 6182 M10	20
8	00000595	895-38.1×220 Pin	3
9	00005413	Bolt GB/T 16674 M10×40	1
10	00000787	Circlips JB/ZQ 4342-38	17
11	10000254	Washer	14
12	10000257	Spacer sleeve	4
13	00000438	8813-38.1×44.45×31.75 Bearing	34
14	00000566	898-38.1×206.5 Pin	4
15	10000255	Chassis slider	2
16	10000425	Hydraulic hoses manifolds	1
17	00000832	Screw GB/T 70.3 M6×25	2
18	10000403	Hose (to upper lift cylinder)	1
19	10001171	Hose (to tank)	1
20	10000402	Hose (to lower lift cylinder)	1
21	00002877	Bolt QC/T 340 M10×35	7
22	10000265	Pothole pusher	2
23	00005412	Bolt GB/T 16674 M10×45	1
24	00000596	895-38.1×236 Pin	1
25	00000220	8902-10080 Pin	4
26	10000278	Outer arm 1	1

**205.1 Scissor Assembly (JCPT1212HA/AC)**

Item	Part No.	Description	Qty.
27	00002096	896B-38.1×25A Pin	2
28		Lower lift cylinder assembly (without seal kit) (refer to 401.1)	1
29	10019581	Inner arm 1	1
30	10002371	Pin	1
31	00008962	Hose clamp	2
32	10000047	Base plate	2
33	00002575	Nut GB/T 6183.1 M8	2
34	00002089	Bolt GB/T 5782 M8×50	2
35	10014451	Inner arm 2	1
36	10011770	Collar	5
37	00000822	Screw GB/T 70.3 M5×16	5
38	10000260	Safety arm bushing	2
39	10000259	Safety arm	2
40	00005263	Bolt QC/T 340 M10×30	4
41	10014454	Cable bridge	2
42	10011771	Clamp	5
43	00000565	898-38.1×199.5 Pin	4
44	10000256	Spacer sleeve	4
45	00000568	898-38.1×638.5 Pin	9
46	10000291	Inner arm 4	1
47	10000264	Block	40
48	00002884	Bolt GB/T 16674 M10×100	2
49	10000252	Platform slider	4
50	00002572	Nut GB/T 6183.1 M10	15
51	00002098	896B-38.1×146 Pin	4
52	00000439	8813-38.1×44.45×50.8 Bearing	6
53	10000293	Outer arm 5	1
54	10000296	Inner arm 5	1

**205.1 Scissor Assembly (JCPT1212HA/AC)**

<b>Item</b>	<b>Part No.</b>	<b>Description</b>	<b>Qty.</b>
55	00002891	Bolt GB/T 16674 M10×110	2

206.1 Scissor Assembly (JCPT1412HA/AC)

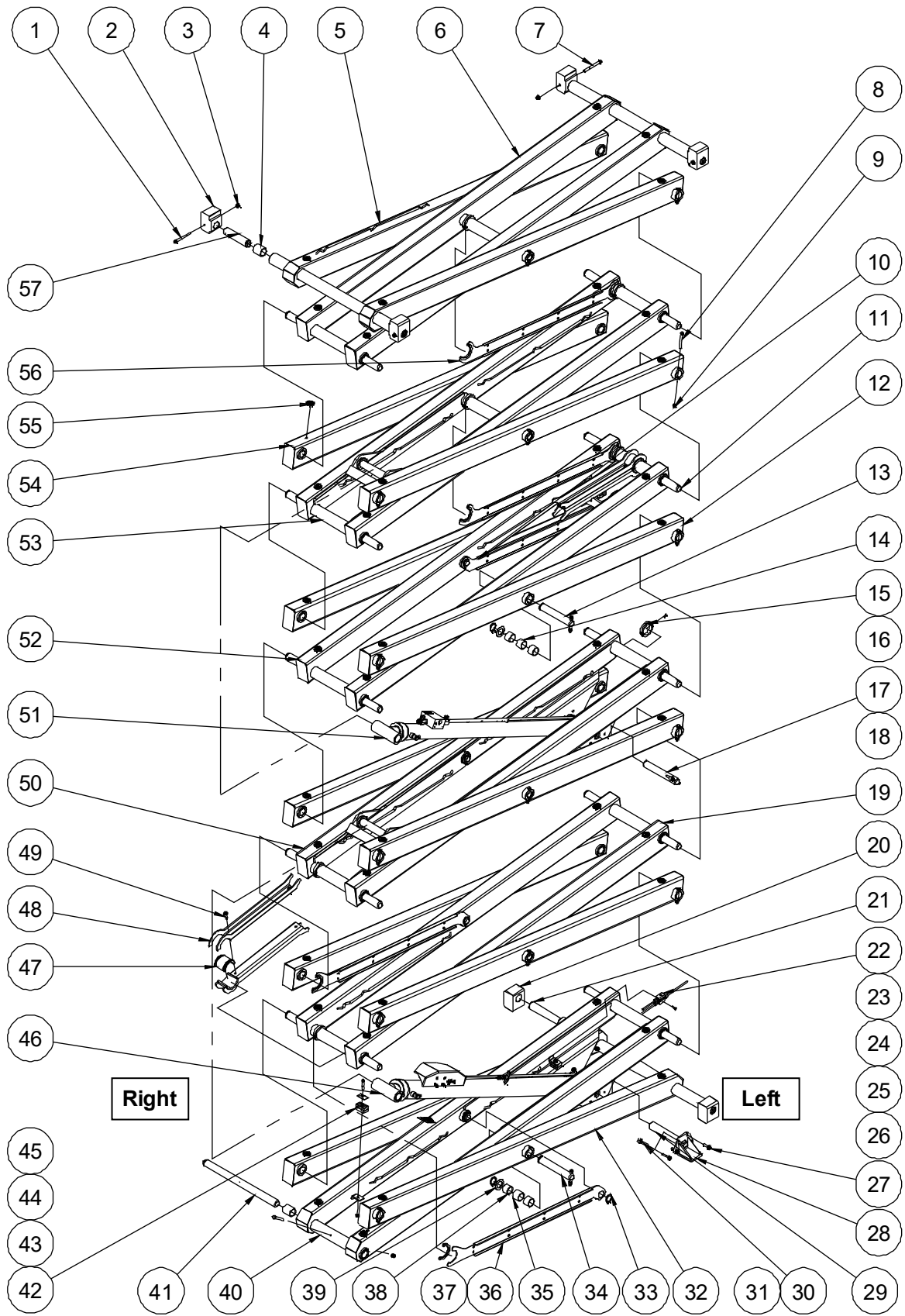

**206.1 Scissor Assembly (JCPT1412HA/AC)**

Item	Part No.	Description	Qty.
1	00002884	Bolt GB/T 16674 M10×100	2
2	10000252	Platform slider	4
3	00002572	Nut GB/T 6183.1 M10	17
4	00000439	8813-38.1×44.45×50.8 Bearing	6
5	10000293	Outer arm 5	1
6	10000739	Inner arm 4	1
7	00002891	Bolt GB/T 16674 M10×110	2
8	00001027	Bolt GB/T 5782 M10×80	23
9	00000623	Nut GB/T 6182 M10	23
10	10000261	Cable bridge	1
11	00000568	898-38.1×638.5 Pin	12
12	10000285	Outer arm	3
--	10014904	Left single link	1
--	10014903	Right single link	1
13	00000565	898-38.1×199.5 Pin	4
14	10000256	Spacer sleeve	4
15	10011770	Collar	7
16	00000822	Screw GB/T 70.3 M5×16	7
17	00000595	895-38.1×220 Pin	3
18	00005413	Bolt GB/T 16674 M10×40	1
19	10014451	Inner arm 2	1
20	10000255	Chassis slider	2
21	00002096	896B-38.1×25A Pin	2
22	10000425	Hydraulic hoses manifolds	1
23	00000832	Screw GB/T 70.3 M6×25	2
24	10000403	Hose (to upper lift cylinder)	1
25	10001171	Hose (to tank)	1
26	10000402	Hose (to lower lift cylinder)	1
27	00002877	Bolt QC/T 340 M10×35	7

**206.1 Scissor Assembly (JCPT1412HA/AC)**

Item	Part No.	Description	Qty.
28	10000265	Pothole pusher	2
29	00000596	895-38.1×236 Pin	1
30	00000220	8902-10080 Pin	4
31	00005412	Bolt GB/T 16674 M10×45	1
32	10000278	Outer arm 1	1
33	00000787	Circlips JB/ZQ 4342-38	20
34	00000566	898-38.1×206.5 Pin	4
35	10000257	Spacer sleeve	4
36	10014454	Cable bridge	2
37	10011771	Clamp	7
38	00000438	8813-38.1×44.45×31.75 Bearing	40
39	10000254	Washer	17
40	10019581	Inner arm 1	1
41	10002371	Pin	1
42	00008962	Hose clamp	2
43	10000047	Base plate	2
44	00002575	Nut GB/T 6183.1 M8	2
45	00002089	Bolt GB/T 5782 M8×50	2
46		Lower lift cylinder assembly (without seal kit) (refer to 401.1)	1
47	10000260	Safety arm bushing	4
48	10000259	Safety arm	4
49	00005263	Bolt QC/T 340 M10×30	6
50	10000286	Inner arm 3	1
51		Upper lift cylinder assembly (without seal kit) (refer to 402.1)	1
52	10000291	Inner arm 4	1
53	10000735	Inner arm 3	1
54	10000736	Outer arm 3	1
--	10014904	Left single link	1

**206.1 Scissor Assembly (JCPT1412HA/AC)**

<b>Item</b>	<b>Part No.</b>	<b>Description</b>	<b>Qty.</b>
--	10014908	Right single link 5	1
55	10000264	Block	48
56	10000044	Cable bridge	2
57	00002098	896B-38.1×146 Pin	4

207.1 Scissor Assembly (JCPT1612HA/AC, JCPT1614HA/AC)

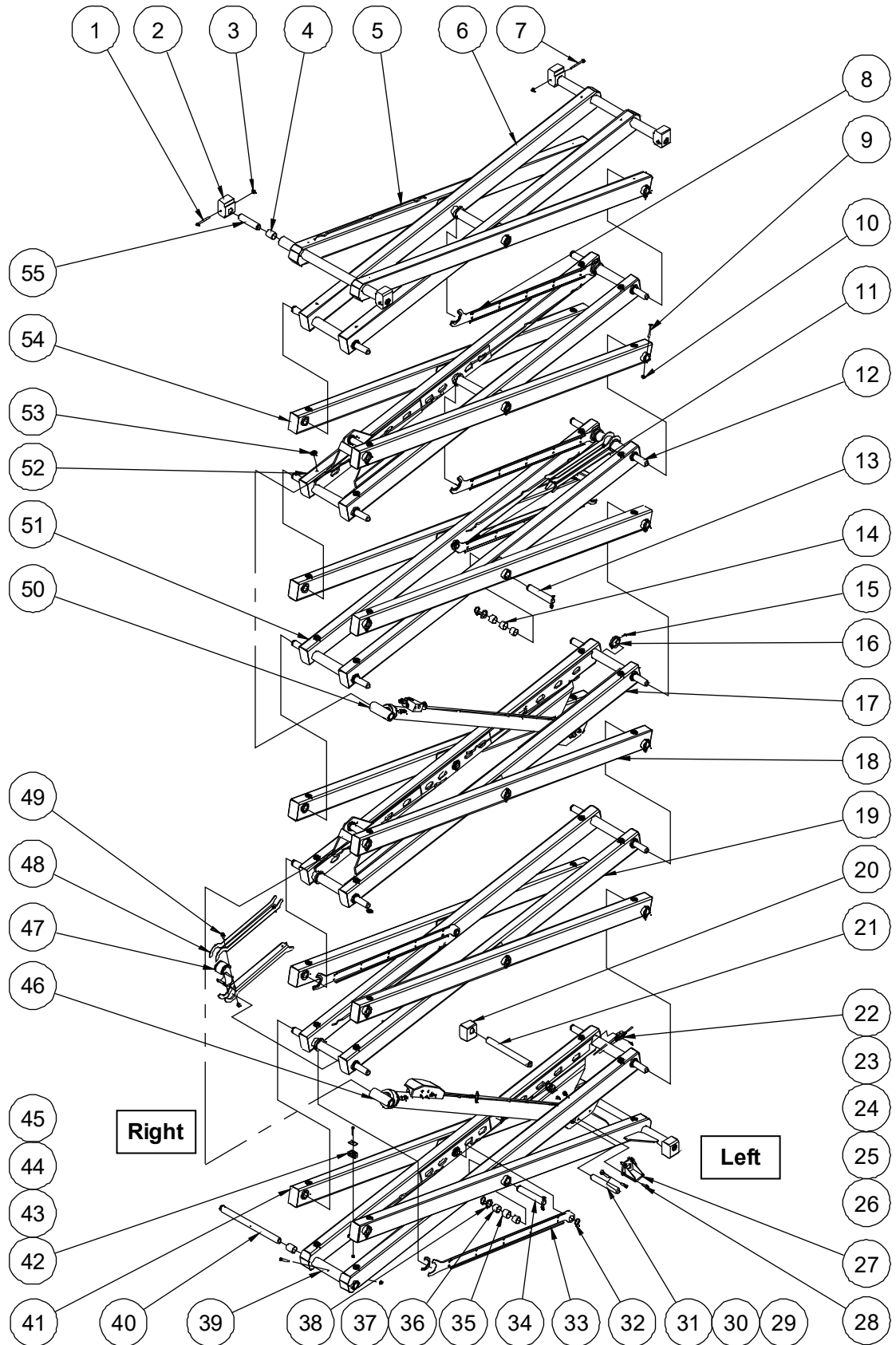

**207.1 Scissor Assembly (JCPT1612HA/AC, JCPT1614HA/AC)**

Item	Part No.	Description	Qty.
1	00002884	Bolt GB/T 16674 M10×100	2
2	10000252	Platform slider	4
3	00002572	Nut GB/T 6183.1 M10	18
4	00000439	8813-38.1×44.45×50.8 Bearing	6
5	10000767	Outer arm 6	1
6	10000769	Inner arm 6	1
7	00002891	Bolt GB/T 16674 M10×110	2
8	10000771	Cable bridge	2
9	00001027	Bolt GB/T 5782 M10×80	23
10	00000623	Nut GB/T 6182 M10	23
11	10000770	Cable bridge	1
12	00000568	898-38.1×638.5 Pin	12
13	00000565	898-38.1×199.5 Pin	4
14	10000256	Spacer sleeve	4
15	00000822	Screw GB/T 70.3 M5×16	7
16	10011770	Collar	7
17	10005558	Inner arm 3	1
18	10000758	Outer arm 2-3	3
--	10014911	Left single link	1
--	10014910	Right single link	1
19	10014457	Inner arm 2	1
20	10000255	Chassis slider	2
21	00002096	896B-38.1×25A Pin (JCPT1612HA/AC)	2
	00002097	896B-38.1×25B Pin (JCPT1614HA/AC)	2
22	10000425	Hydraulic hoses manifolds	1
23	00000832	Screw GB/T 70.3 M6×25	2
24	10000085	Hose (to upper lift cylinder)	1
25	10001172	Hose (to tank)	1
26	10000084	Hose (to lower lift cylinder)	1

**207.1 Scissor Assembly (JCPT1612HA/AC, JCPT1614HA/AC)**

Item	Part No.	Description	Qty.
27	10000265	Pothole pusher	2
28	00002877	Bolt QC/T 340 M10×35	8
29	00005413	Bolt GB/T 16674 M10×40	2
30	00000220	8902-10080 Pin	4
31	00000595	895-38.1×220 Pin	4
32	00000787	Circlips JB/ZQ 4342-38	20
33	10014460	Cable bridge	2
34	00000566	898-38.1×206.5 Pin	4
35	10000257	Spacer sleeve	4
36	00000438	8813-38.1×44.45×31.75 Bearing	40
37	10011771	Clamp	7
38	10000254	Washer	17
39	10019583	Inner arm 1	1
40	10002371	Pin	1
41	10000753	Outer arm 1 (JCPT1612HA/AC)	1
	10000774	Outer arm 1 (JCPT1614HA/AC)	1
42	00000539	Hose clamp	2
43	10000047	Base plate	2
44	00002575	Nut GB/T 6183.1 M8	2
45	00002089	Bolt GB/T 5782 M8×50	2
46		Lower lift cylinder assembly (without seal kit) (refer to 401.1)	1
47	10000260	Safety arm bushing	4
48	10000259	Safety arm	4
49	00005263	Bolt QC/T 340 M10×30	6
50		Upper lift cylinder assembly (without seal kit) (refer to 402.1)	1
51	10000766	Inner arm 4	1
52	10005555	Inner arm 5	1
53	10000264	Block	48

**207.1 Scissor Assembly (JCPT1612HA/AC, JCPT1614HA/AC)**

<b>Item</b>	<b>Part No.</b>	<b>Description</b>	<b>Qty.</b>
54	10000760	Outer arm 5	1
--	10014911	Left single link	1
--	10014912	Right single link 5	1
55	00002098	896B-38.1×146 Pin	4

208.1 Scissor Assembly (JCPT1612HAS/ACS)

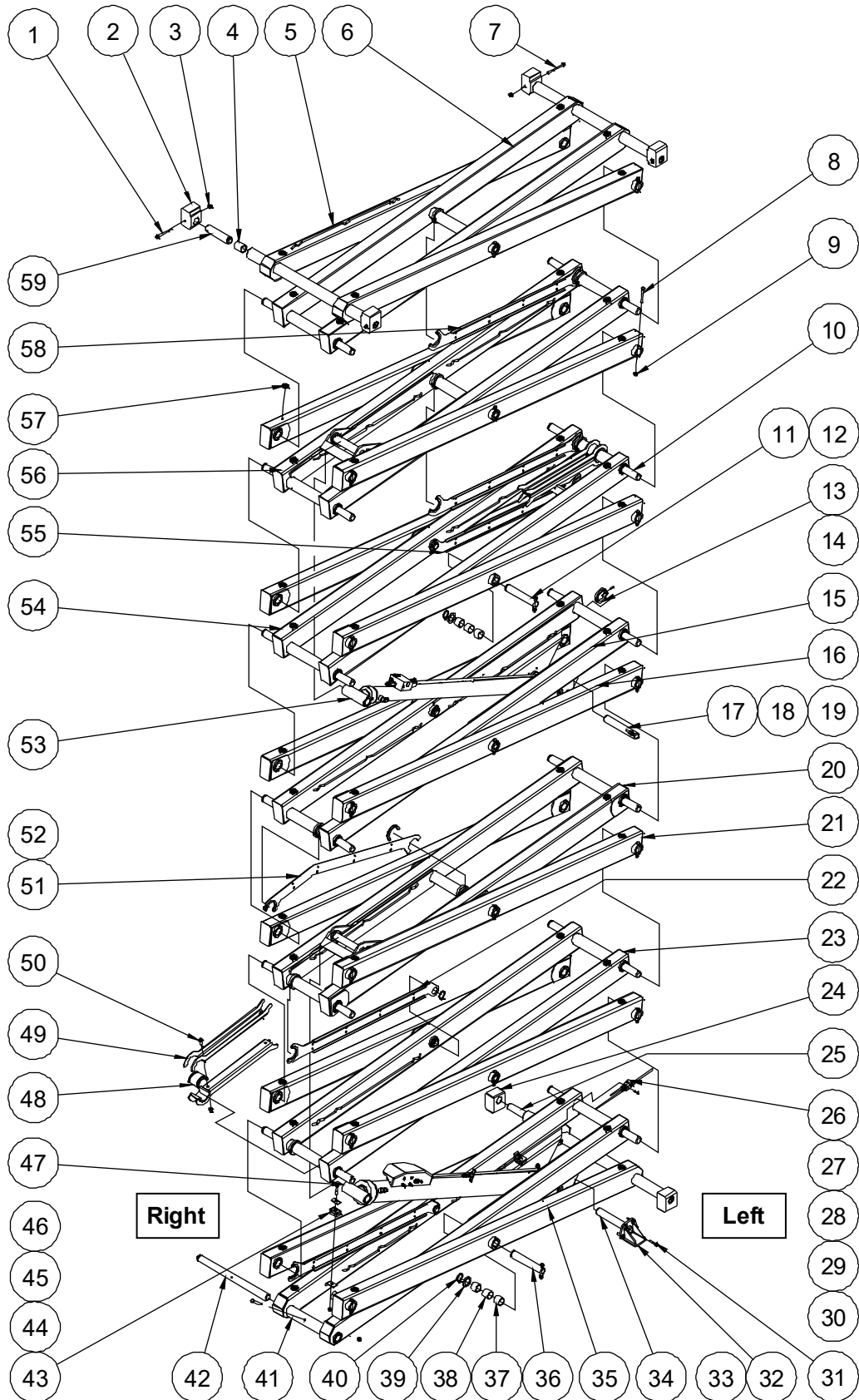

**208.1 Scissor Assembly (JCPT1612HAS/ACS)**

Item	Part No.	Description	Qty.
1	00002884	Bolt GB/T 16674 M10×100	2
2	10000252	Platform slider	4
3	00002572	Nut GB/T 6183.1 M10	17
4	00000439	8813-38.1×44.45×50.8 Bearing	6
5	10000293	Outer arm 5	1
6	10000739	Inner arm 4	1
7	00002891	Bolt GB/T 16674 M10×110	2
8	00001027	Bolt GB/T 5782 M10×80	26
9	00000623	Nut GB/T 6182 M10	26
10	00000568	898-38.1×638.5 Pin	15
11	00000565	898-38.1×199.5 Pin	4
12	10000256	Spacer sleeve	4
13	10011770	Collar	11
14	00000822	Screw GB/T 70.3 M5×16	11
15	10005727	Inner arm 4	1
16	10006738	Outer arm 2	3
--	10014915	Left single link	1
--	10014914	Right single link	1
17	00000595	895-38.1×220 Pin	3
18	00000220	8902-10080 Pin	4
19	00005413	Bolt GB/T 16674 M10×40	1
20	10005812	Inner arm 3	1
21	10007395	Outer arm 3	2
--	10014915	Left single link	1
--	10014916	Right single link 3	1
22	10014454	Cable bridge	2
23	10014451	Inner arm 2	1
24	10000255	Chassis slider	2
25	00002096	896B-38.1×25A Pin	2

**208.1 Scissor Assembly (JCPT1612HAS/ACS)**

Item	Part No.	Description	Qty.
26	10000425	Hydraulic hoses manifolds	1
27	00000832	Screw GB/T 70.3 M6×25	2
28	10000085	Hose (to upper lift cylinder)	1
29	10001171	Hose (to tank)	1
30	10000402	Hose (to lower lift cylinder)	1
31	00005412	Bolt GB/T 16674 M10×45	1
32	10000265	Pothole pusher	2
33	00002877	Bolt QC/T 340 M10×35	7
34	00000596	895-38.1×236 Pin	1
35	10000278	Outer arm 1	1
36	00000566	898-38.1×206.5 Pin	4
37	00000438	8813-38.1×44.45×31.75 Bearing	46
38	10000257	Spacer sleeve	4
39	10000254	Washer	20
40	00000787	Circlips JB/ZQ 4342-38	23
41	10019581	Inner arm 1	1
42	10002371	Pin	1
43	00008962	Hose clamp	2
44	10000047	Base plate	2
45	00002575	Nut GB/T 6183.1 M8	2
46	00002089	Bolt GB/T 5782 M8×50	2
47		Lower lift cylinder assembly (without seal kit) (refer to 401.1)	1
48	10000260	Safety arm bushing	4
49	10000259	Safety arm	4
50	00005263	Bolt QC/T 340 M10×30	6
51	10011841	Cable bridge	1
52	10011771	Clamp	9
53		Upper lift cylinder assembly (without seal kit) (refer to 402.1)	1

**208.1 Scissor Assembly (JCPT1612HAS/ACS)**

<b>Item</b>	<b>Part No.</b>	<b>Description</b>	<b>Qty.</b>
54	10000291	Inner arm 4	1
55	10000261	Cable bridge	1
56	10000735	Inner arm 3	1
57	10000264	Block	56
58	10000044	Cable bridge	2
59	00002098	896B-38.1×146 Pin	4

# **Section 3 Platform**

**301.1 Main Platform Assembly (JCPT0808HA/AC,  
JCPT1008HA/AC)**

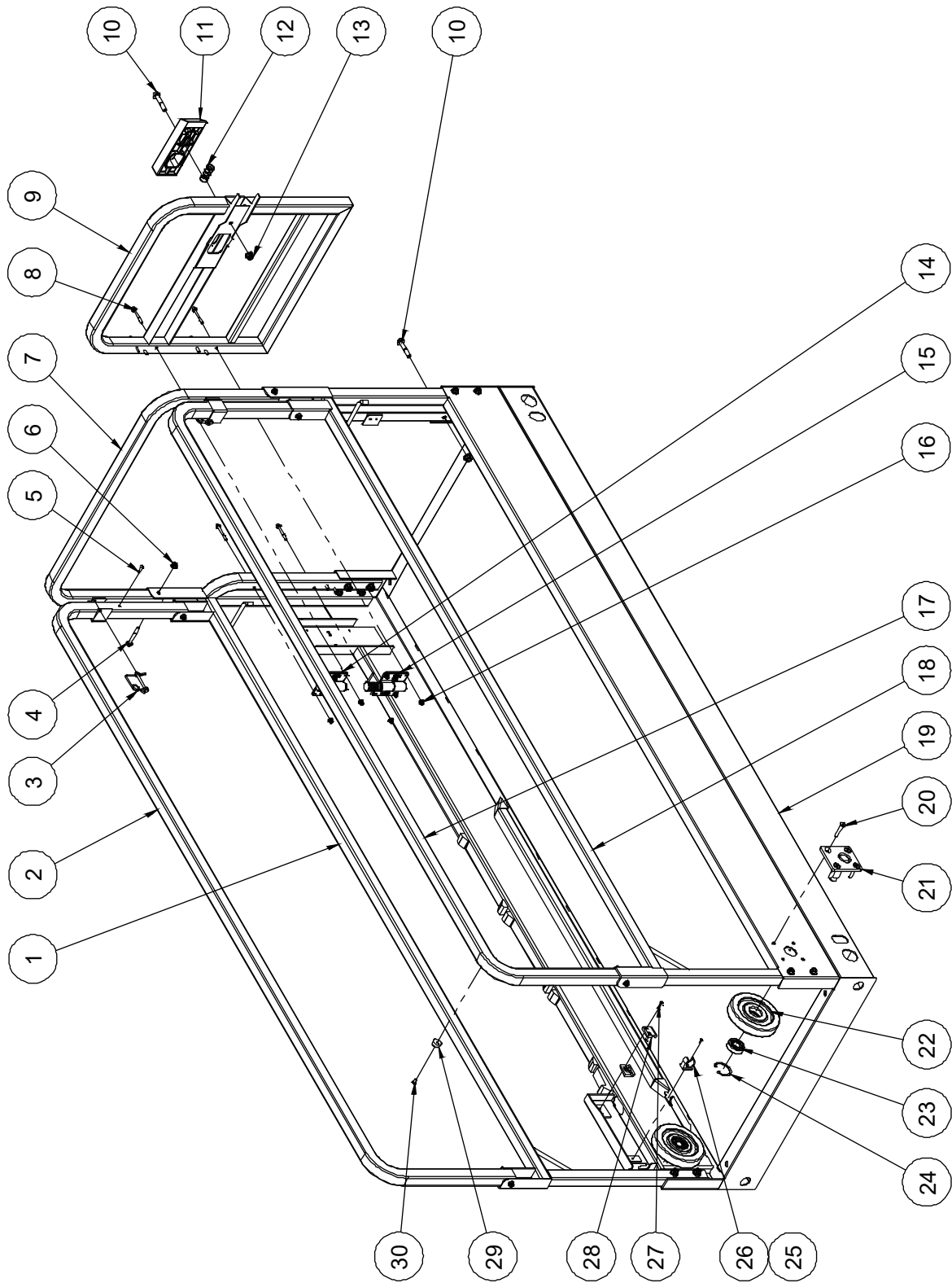

### 301.1 Main Platform Assembly (JCPT0808HA/AC, JCPT1008HA/AC)

Item	Part No.	Description	Qty.
1	10002069	Lower main rail, right	1
2	10000716	Upper main rail, right	1
3	10001178	Inserted pin	2
4	00002568	Bolt GB/T 16674 M8×60	6
5	00001991	Rivet GB/T 12618.4 4.8×16	2
6	00002575	Nut GB/T 6183.1 M8	6
7	10002077	Rear rail	1
8	00002581	Bolt GB/T 16674 M6×50	12
9	10002085	Entry gate	1
10	00002547	Bolt GB/T 16674 M10×55	13
11	10000331	Latch handle	1
12	10000367	Spring	1
13	00002572	Nut GB/T 6183.1 M10	13
14	10000299	Hinge A	1
15	10000302	Hinge B	1
16	00002574	Nut GB/T 6183.1 M6	12
17	10002076	Upper main rail, left	1
18	10002073	Lower main rail, left	1
19	10014879	Main deck weldment	1
20	00001154	Screw GB/T 70.3 M8×45	8
21	10000307	Roller bracket	2
22	10002031	Roller	2
23	00001295	Bearing GB/T 276-1994 - 6204	2
24	00000887	Circlips GB/T 893.1-47	2
25	00004385	Screw GB/T 823 M4×8	1
26	00001823	Clip 24	1
27	00002064	Screw GB/T 70.1 M4×20	2
28	10001776	Wire clip	2

**301.1 Main Platform Assembly (JCPT0808HA/AC,  
JCPT1008HA/AC)**

<b>Item</b>	<b>Part No.</b>	<b>Description</b>	<b>Qty.</b>
29	10000376	Bumper	1
30	00001011	Screw GB/T 973 M5×12	1

**302.1 Platform Extension Assembly (JCPT0808HA/AC,  
JCPT1008HA/AC)**

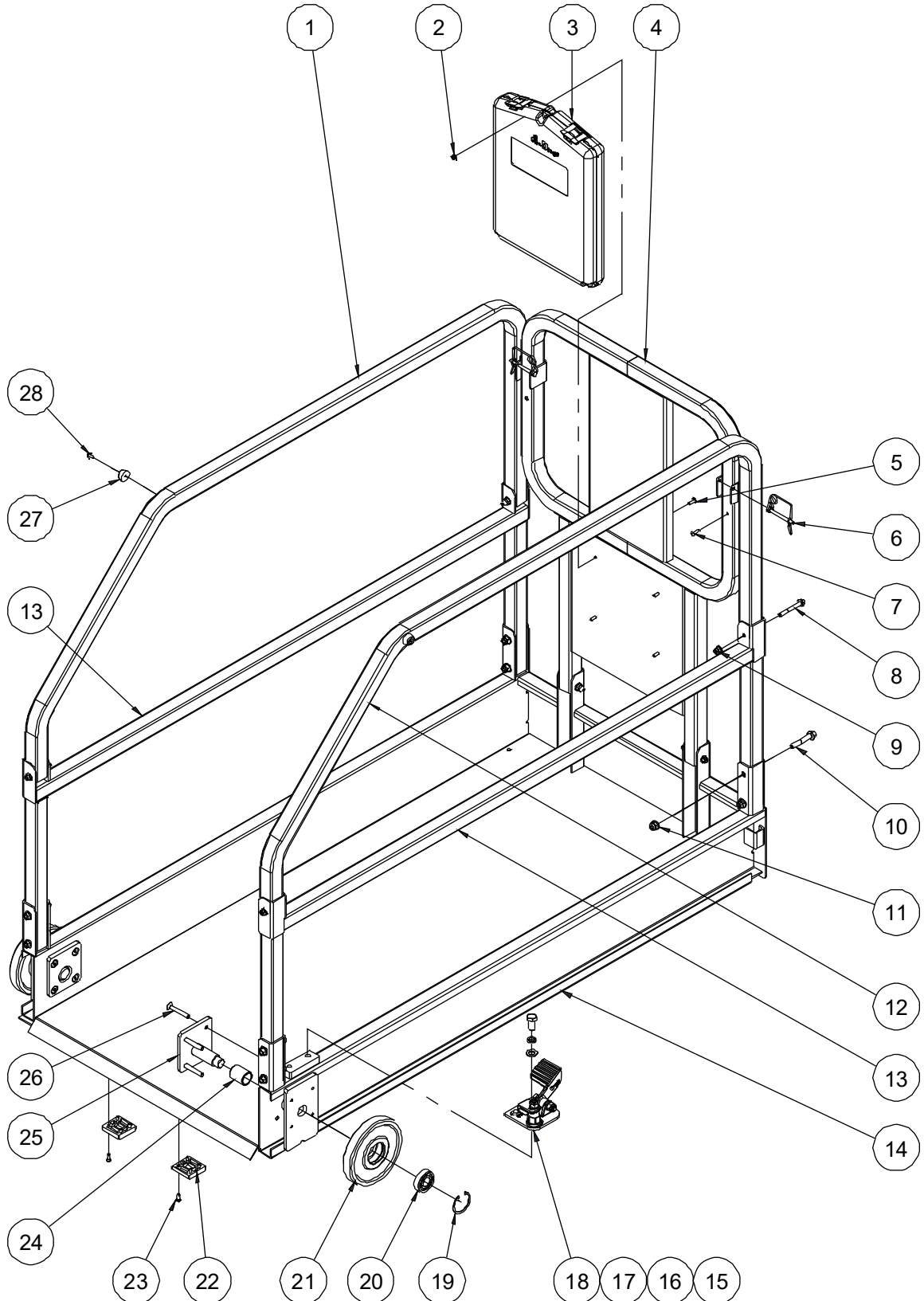

### 302.1 Platform Extension Assembly (JCPT0808HA/AC, JCPT1008HA/AC)

Item	Part No.	Description	Qty.
1	10002074	Left extension rail	1
2	00002573	Nut GB/T 6183.1 M5	4
3	50000555	Manual box	1
4	10000709	Front rail	1
5	00002523	Screw GB/T 973 M5×16	4
6	10001178	Inserted pin	2
7	00001991	Rivet GB/T 12618.4 4.8×16	2
8	00002568	Bolt GB/T 16674 M8×60	6
9	00002575	Nut GB/T 6183.1 M8	6
10	00002547	Bolt GB/T 16674 M10×55	8
11	00002572	Nut GB/T 6183.1 M10	8
12	10000703	Right extension rail	1
13	10002072	Lower extension rail	2
14	10014881	Extension deck weldment	1
15	00000816	Bolt GB/T 5783 M12×25	1
16	00000815	Washer GB/T 93 12	1
17	00000814	Washer GB/T 97.1 12	1
18	10012174	Platform locking device assembly (refer to 305.1)	1
19	00000887	Circlips GB/T 893.1-47	2
20	00001295	Bearing GB/T 276-1994 - 6204	2
21	10000305	Roller 2	2
22	10000046	Slide pad	2
23	00000822	Screw GB/T 70.3 M5×16	8
24	10017994	8812-263036 Bearing	2
25	10000307	Roller bracket	2
26	00001155	Screw GB/T 70.3 M8×55	8
27	10000376	Bumper	2
28	00001011	Screw GB/T 973 M5×12	2

**303.1 Main Platform Assembly (JCPT0812HA/AC, JCPT1012HA/AC, JCPT1212HA/AC, JCPT1412HA/AC, JCPT1612HA/AC, JCPT1612HAS/ACS, JCPT1614HA/AC)**

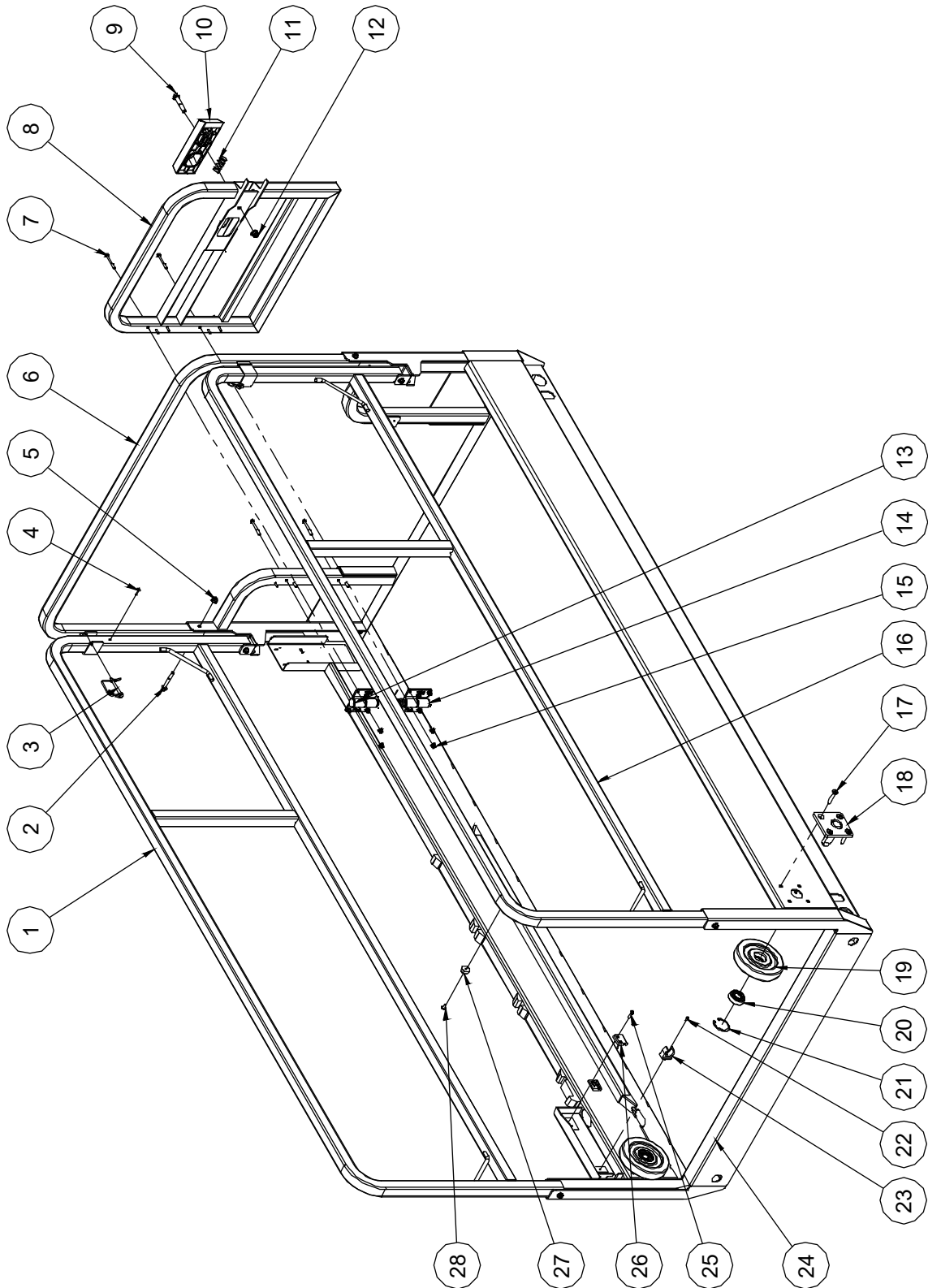

### 303.1 Main Platform Assembly (JCPT0812HA/AC, JCPT1012HA/AC, JCPT1212HA/AC, JCPT1412HA/AC, JCPT1612HA/AC, JCPT1612HAS/ACS, JCPT1614HA/AC)

Item	Part No.	Description	Qty.
1	10016095	Right main rail (JCPT0812HA/AC, JCPT1012HA/AC, JCPT1212HA/AC, JCPT1412HA/AC, JCPT1612HAS/ACS)	1
	10000891	Right main rail (JCPT1612HA/AC, JCPT1614HA/AC)	1
2	00002568	Bolt GB/T 16674 M8×60	6
3	10001178	Inserted pin	2
4	00001991	Rivet GB/T 12618.4 4.8×16	2
5	00002575	Nut GB/T 6183.1 M8	6
6	10000374	Rear rail	1
7	00002581	Bolt GB/T 16674 M6×50	12
8	10000368	Entry gate	1
9	00002547	Bolt GB/T 16674 M10×55	1
10	10000331	Latch handle	1
11	10000367	Spring	1
12	00002572	Nut GB/T 6183.1 M10	1
13	10000299	Hinge A	1
14	10000302	Hinge B	1
15	00002574	Nut GB/T 6183.1 M6	12
16	10016094	Left main rail (JCPT0812HA/AC, JCPT1012HA/AC, JCPT1212HA/AC, JCPT1412HA/AC, JCPT1612HAS/ACS)	1
	10000887	Left main rail (JCPT1612HA/AC, JCPT1614HA/AC)	1
17	00001154	Screw GB/T 70.3 M8×45	8
18	10000307	Roller bracket	2
19	10002031	Roller	2
20	00001295	Bearing GB/T 276-1994 - 6204	2
21	00000887	Circlips GB/T 893.1-47	2
22	00004385	Screw GB/T 823 M4×8	1
23	00001823	Clip 24	1

**303.1 Main Platform Assembly (JCPT0812HA/AC,  
JCPT1012HA/AC, JCPT1212HA/AC, JCPT1412HA/AC,  
JCPT1612HA/AC, JCPT1612HAS/ACS, JCPT1614HA/AC)**

Item	Part No.	Description	Qty.
24	10012801	Main deck weldment (JCPT0812HA/AC, JCPT1012HA/AC, JCPT1212HA/AC, JCPT1412HA/AC, JCPT1612HAS/ACS)	1
	10012813	Main deck weldment (JCPT1612HA/AC, JCPT1614HA/AC)	1
25	00002064	Screw GB/T 70.1 M4×20	2
26	10001776	Wire clip	2
27	10000376	Bumper	1
28	00001011	Screw GB/T 973 M5×12	1

**304.1 Platform Extension Assembly (JCPT0812HA/AC, JCPT1012HA/AC, JCPT1212HA/AC, JCPT1412HA/AC, JCPT1612HA/AC JCPT1612HAS/ACS, JCPT1614HA/AC)**

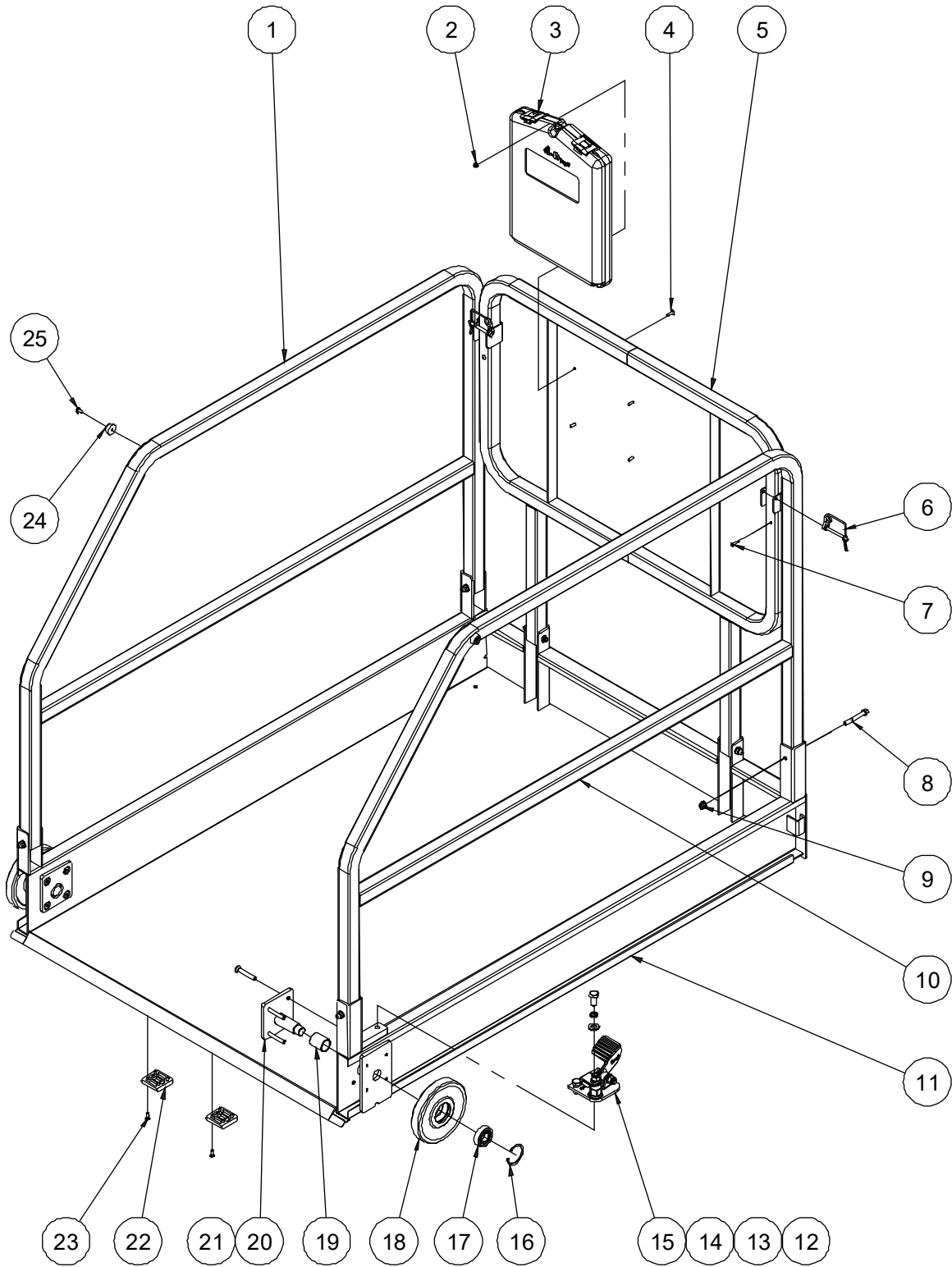

**304.1 Platform Extension Assembly (JCPT0812HA/AC, JCPT1012HA/AC, JCPT1212HA/AC, JCPT1412HA/AC, JCPT1612HA/AC JCPT1612HAS/ACS, JCPT1614HA/AC)**

Item	Part No.	Description	Qty.
1	10000354	Left extension rail	1
2	00002573	Nut GB/T 6183.1 M5	4
3	50000555	Manual box	1
4	00002523	Screw GB/T 973 M5×16	4
5	10000357	Front rail	1
6	10001178	Inserted pin	2
7	00001991	Rivet GB/T 12618.4 4.8×16	2
8	00002568	Bolt GB/T 16674 M8×60	6
9	00002575	Nut GB/T 6183.1 M8	6
10	10000361	Right extension rail	1
11	10012808	Extension deck weldment	1
12	00000814	Washer GB/T 97.1 12	1
13	00000815	Washer GB/T 93 12	1
14	00000816	Bolt GB/T 5783 M12×25	2
15	10012174	Platform locking device assembly (refer to 305.1)	1
16	00000887	Circlips GB/T 893.1-47	2
17	00001295	Bearing GB/T 276-1994 - 6204	2
18	10000305	Roller 2	2
19	10017994	8812-263036 Bearing	2
20	10000307	Roller bracket	2
21	00001155	Screw GB/T 70.3 M8×55	8
22	10000046	Slide pad	2
23	00000822	Screw GB/T 70.3 M5×16	8
24	10000376	Bumper	2
25	00001011	Screw GB/T 973 M5×12	2

### 305.1 Platform Locking Device Assembly

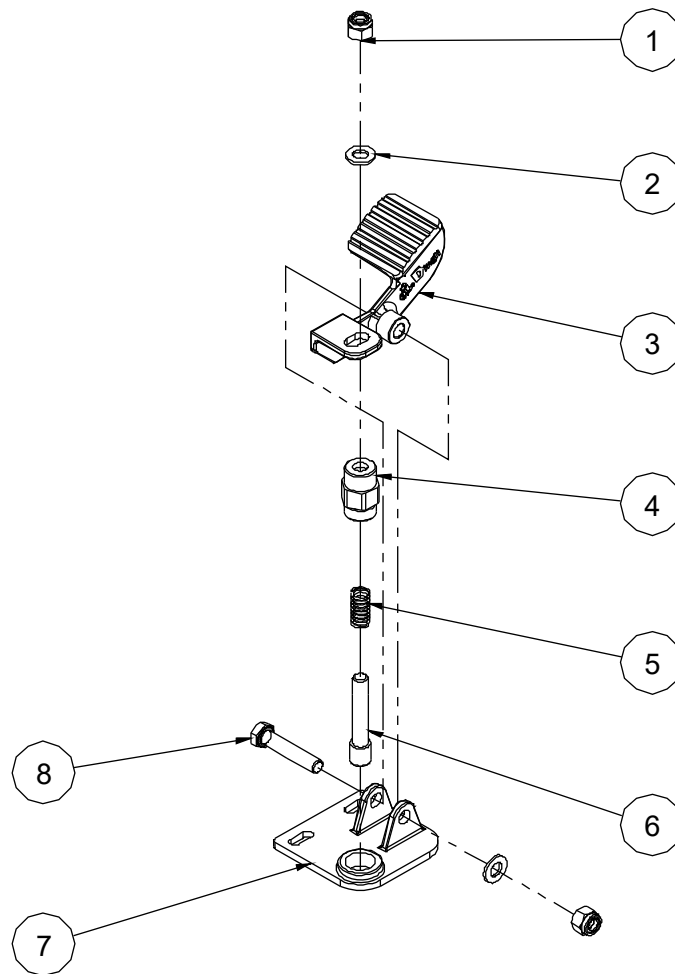

### 305.1 Platform Locking Device Assembly

Item	Part No.	Description	Qty.
1	00000623	Nut GB/T 6182 M10	2
2	00000615	Washer GB/T 97.1 10	2
3	10000334	Foot pedal	1
4	10000337	Lock pin housing	1
5	10000336	Spring	1
6	10000338	Lock pin	1
7	10012175	Bracket	1
8	00002030	Bolt GB/T 5782 M10×50	1

**306.1 Platform Control Assembly**

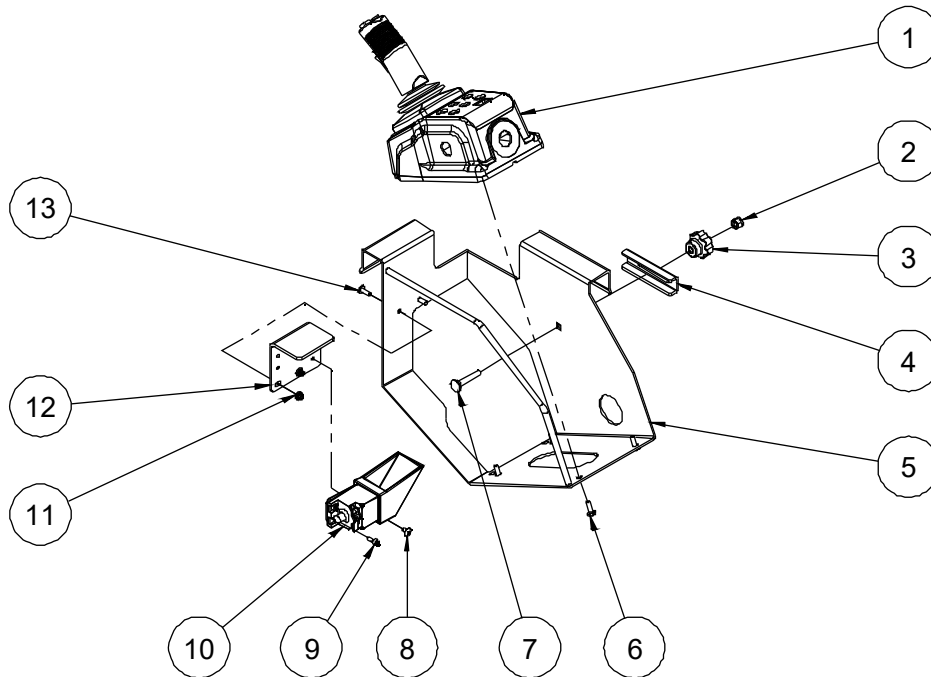

**306.1 Platform Control Assembly**

Item	Part No.	Description	Qty.
1	00006872	Platform control box assembly (refer to 307.1)	1
2	00001163	Nut GB/T 6182 M8	1
3	10004827	Handle	1
4	10002023	Locating plate	1
5	10000390	Platform control box mount bracket	1
6	00001986	Screw GB/T 818 M6×16 - H	4
7	00004384	Bolt GB/T 801 M8×45	1
8	00001010	Screw GB/T 973 M5×8 (option)	1
9	00001252	Screw GB/T 70.1 M5×12 (option)	2
10	00006871	Ultrasonic sensor (option)	1
11	00002573	Nut GB/T 6183.1 M5 (option)	2
12	10012853	Sensor bracket (option)	1
13	00002523	Screw GB/T 973 M5×16 (option)	2

### 307.1 Platform Control Box Assembly

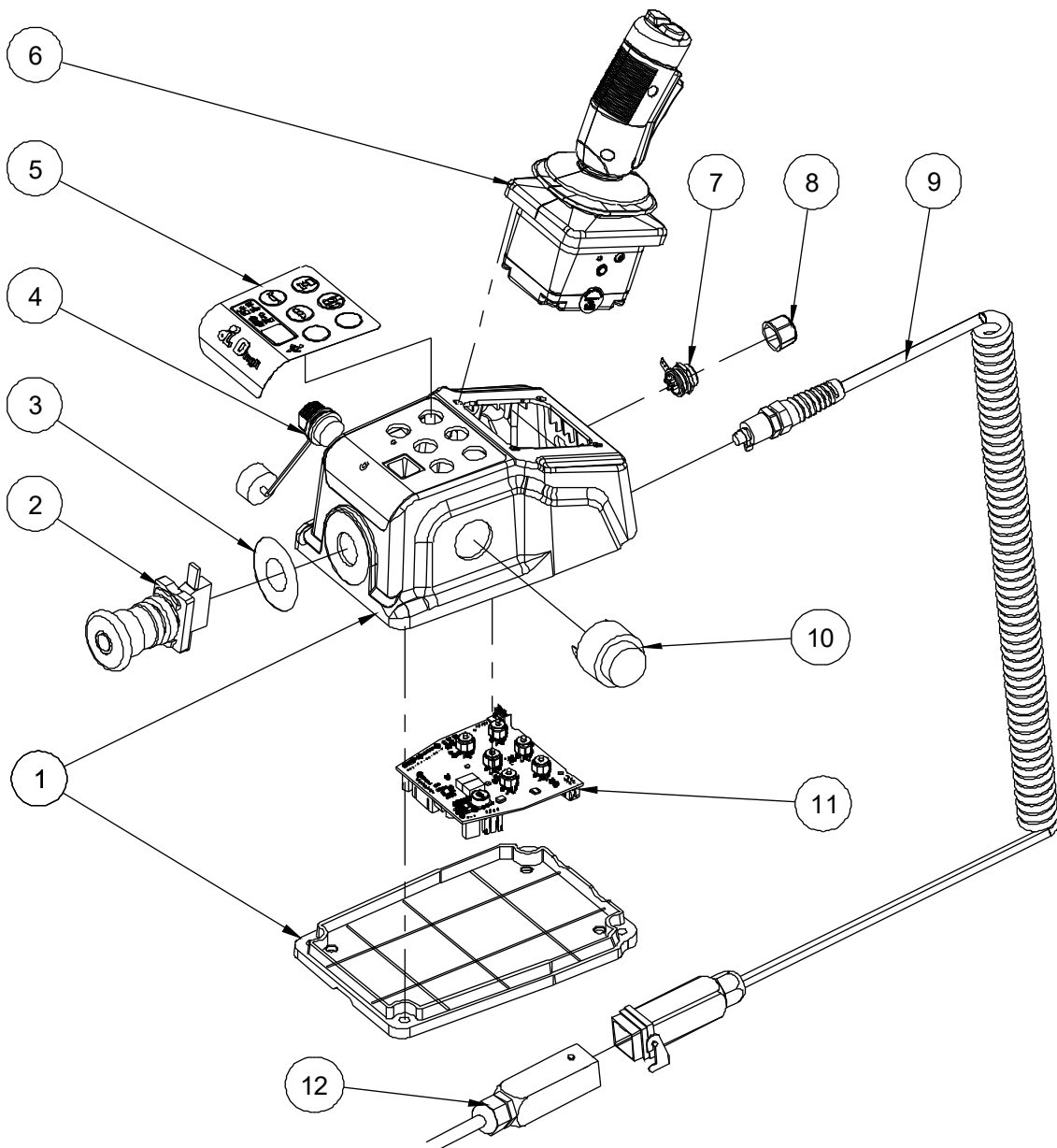

**307.1 Platform Control Box Assembly**

Item	Part No.	Description	Qty.
1	00008649	Shell components	1
2	00000713	Emergency stop switch	1
--	00003045	Red mushroom head	1
--	00003046	Base with 1 NO contact	1
3	00002328	Decal, Emergency stop panel	1
4	00008650	USB Cable	1
5	00008646	Decal, Platform control panel	1
6	00009010	Joystick	1
--	00003033	Function enable switch	1
--	00009012	Joystick cover	1
--	00003035	Joystick steer switch	1
--	00003036	Switch boot	1
7	00008651	Connector	1
8	00008652	Connector Cap	1
9	00008647	Coil cord	1
--	00007855	Hood	1
--	00007856	Female insert	1
--	00007857	Female contacts	5
--	00003043	Cable gland	1
10	00000712	Alarm	1
--	00003044	Alarm nut	1
11	00008648	PCU Main board	1
12	00007728	Platform control box harness (JCPT0808HA/AC)	1
	00008450	Platform control box harness (JCPT0812HA/AC)	1
	00007726	Platform control box harness (JCPT1008HA/AC)	1
	00007722	Platform control box harness (JCPT1012HA/AC)	5
	00007705	Platform control box harness (JCPT1212HA/AC)	1
	00007701	Platform control box harness (JCPT1412HA/AC)	1

**307.1 Platform Control Box Assembly**

<b>Item</b>	<b>Part No.</b>	<b>Description</b>	<b>Qty.</b>
12	00007716	Platform control box harness (JCPT1612HA/AC, JCPT1614HA/AC)	1
	00008547	Platform control box harness (JCPT1612HAS/ACS)	1
--	00008172	Housing	1
--	00008174	Male insert	1
--	00008642	Male contacts	5
--	00003043	Cable gland	1

**308.1 Protective Device Assembly (JCPT0808HA/AC,  
JCPT1008HA/AC) (Option)**

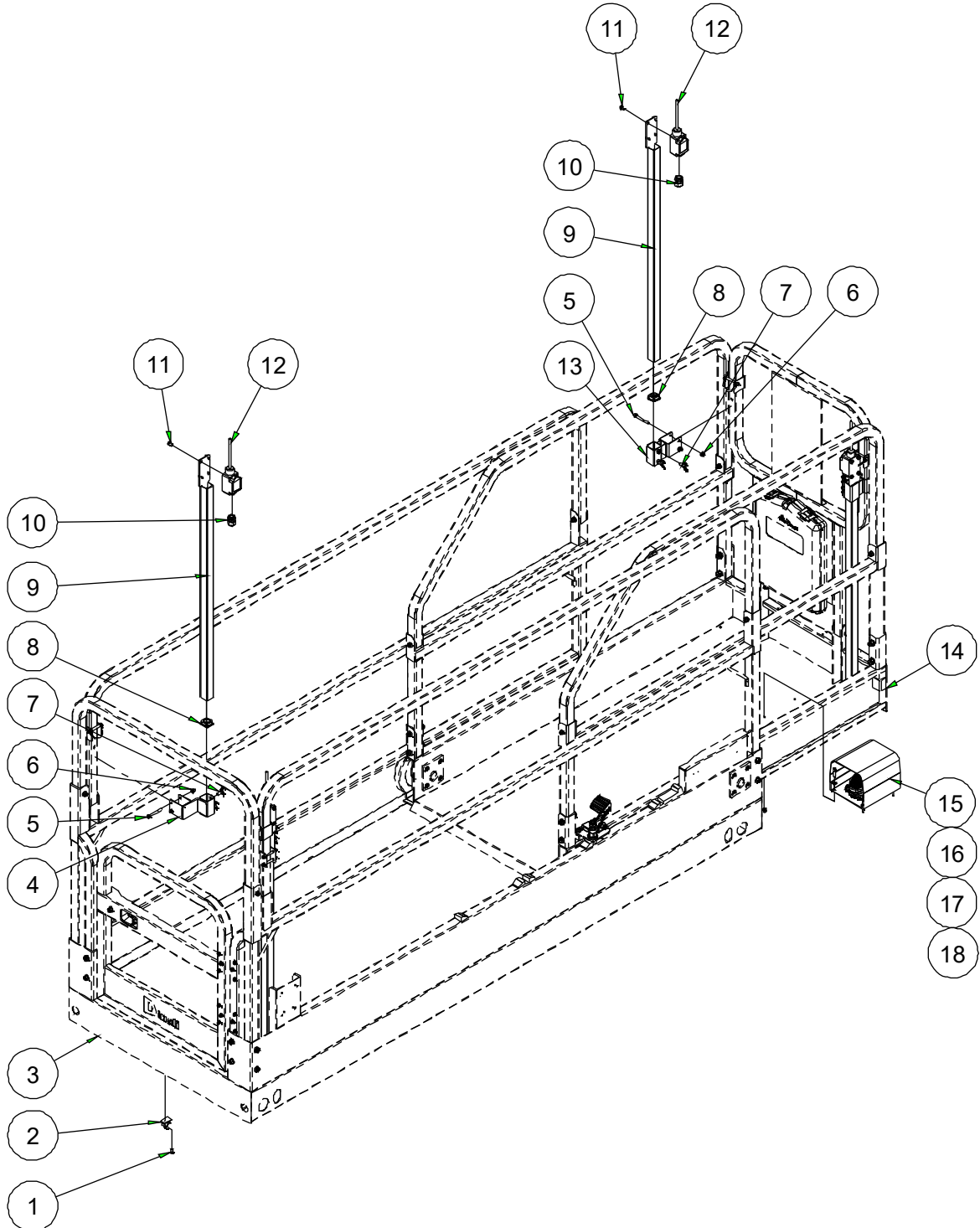

### 308.1 Protective Device Assembly (JCPT0808HA/AC, JCPT1008HA/AC) (Option)

Item	Part No.	Description	Qty.
1	00003950	Screw GB/T 819 M4×10 - H	1
2	00002758	Wire clip	1
3	10017849	Main deck weldment	1
4	10002137	Bracket	2
5	00002569	Bolt GB/T 16674 M6×55	8
6	00002574	Nut GB/T 6183.1 M6	8
7	00002586	Screw M8×16	8
8	10003413	Plug	4
9	10001704	Switch rod	4
10	00001827	Water-proof joint M18	4
11	00001060	Screw GB/T 818 M6×12 - H	16
12	00002606	Limit switch	4
13	10001745	Bracket	2
14	10017850	Extension deck weldment	1
15	00007858	Footswitch	1
16	00001034	Screw GB/T 70.1 M6×25	4
17	00000620	Washer GB/T 97.1 6	4
18	00002574	Nut GB/T 6183.1 M6	4

**309.1 Protective Device Assembly (JCPT1012HA/AC, JCPT1212HA/AC, JCPT1412HA/AC, JCPT1612HA/AC) (Option)**

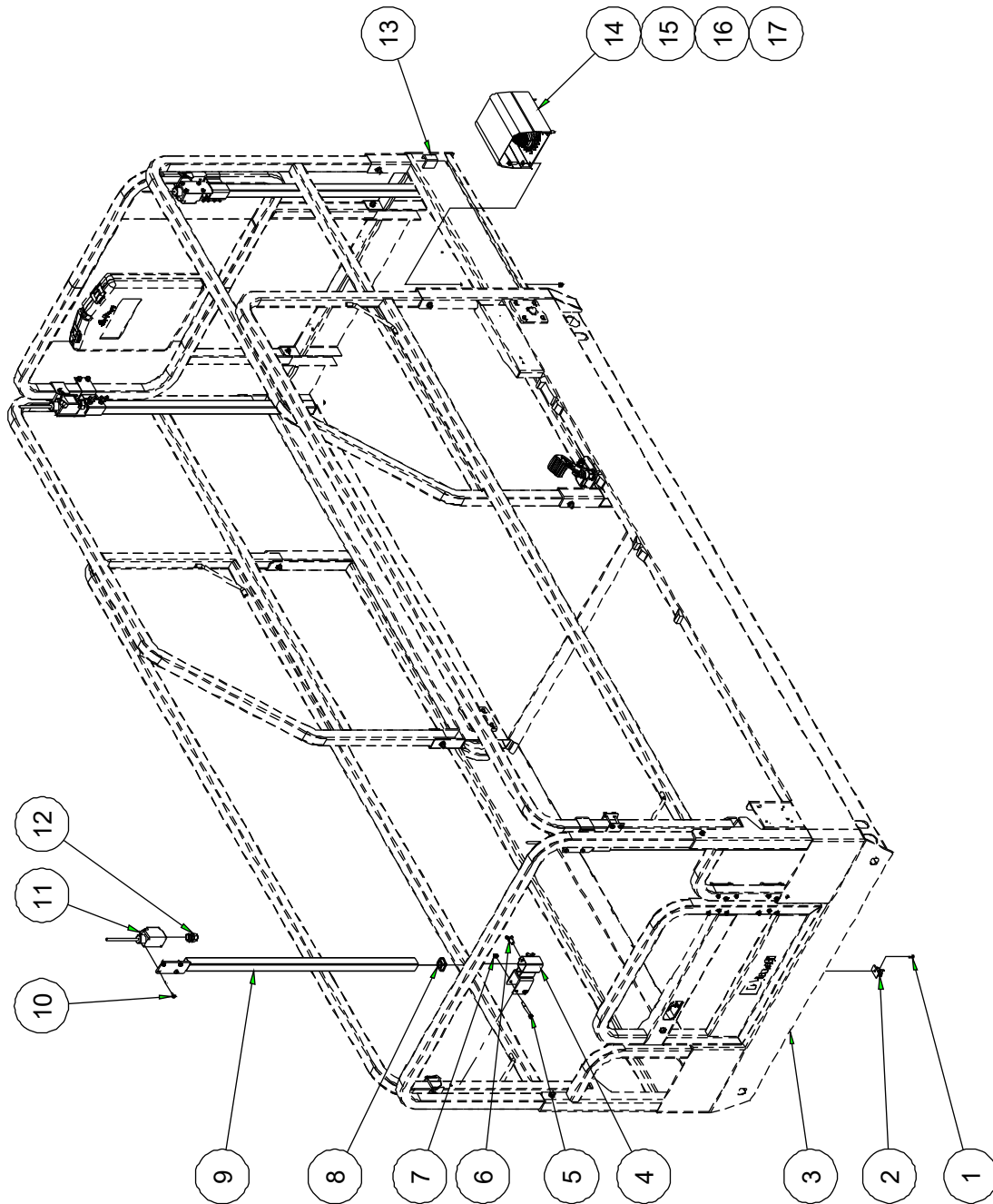

### 309.1 Protective Device Assembly (JCPT1012HA/AC, JCPT1212HA/AC, JCPT1412HA/AC, JCPT1612HA/AC) (Option)

Item	Part No.	Description	Qty.
1	00003950	Screw GB/T 819 M4×10 - H	1
2	00002758	Wire clip	1
3	10017833	Main deck weldment (JCPT1012HA/AC, JCPT1212HA/AC, JCPT1412HA/AC)	1
	10017845	Main deck weldment (JCPT1612HA/AC)	1
4	10001745	Bracket	4
5	00002569	Bolt GB/T 16674 M6×55	8
6	00002586	Screw M8×16	8
7	00002574	Nut GB/T 6183.1 M6	8
8	10003413	Plug	4
9	10001704	Switch rod	4
10	00001060	Screw GB/T 818 M6×12 - H	16
11	00002606	Limit switch	4
12	00001827	Water-proof joint M18	4
13	10017832	Extension deck weldment	1
14	00007858	Footswitch	1
15	00001034	Screw GB/T 70.1 M6×25	4
16	00000620	Washer GB/T 97.1 6	4
17	00002574	Nut GB/T 6183.1 M6	4

# **Section 4 Hydraulic System**



**401.1 Lower Lift Cylinder Assembly**

Item	Part No.	Description	Qty.
1	10000441	Lower lift cylinder (JCPT0808HA/AC, JCPT0812HA/AC, JCPT1008HA/AC, JCPT1012HA/AC, JCPT1212HA/AC, JCPT1412HA/AC)	1
	10020360	Lower lift cylinder (JCPT1612HA/AC, JCPT1614HA/AC)	1
	10005729	Lower lift cylinder (JCPT1612HAS/ACS)	1
2	00007393	Pressure sensor (current signal)	1
	00000696	Pressure sensor (voltage signal)	1
	00001073	Plug VSTI14×1.5ED (no pressure sensor)	1
3	00001073	Plug VSTI14×1.5ED	1
4	00003027	Orifice $\Phi$ 1.5 (JCPT0808HA/AC, JCPT0812HA/AC, JCPT1008HA/AC, JCPT1012HA/AC, JCPT1212HA/AC, JCPT1412HA/AC, JCPT1612HA/AC, JCPT1614HA/AC)	1
	00003014	Orifice $\Phi$ 1.1 (JCPT1612HA/AC, JCPT1614HA/AC)	1
	00005410	Orifice 3/8-16_ $\Phi$ 1.2 (JCPT1612HAS/ACS)	1
5	00002998	Plug SAE4	1
6	10000404	Check valve	1
7	00001292	Straight fitting	1
8	00001833	Elbow (JCPT1212HA/AC, JCPT1412HA/AC, JCPT1612HA/AC, JCPT1612HAS/ACS, JCPT1614HA/AC)	1
9	00001238	Tee fitting (JCPT1212HA/AC, JCPT1412HA/AC, JCPT1612HA/AC, JCPT1612HAS/ACS, JCPT1614HA/AC)	1
10	10000410	Lowering knob JB/T 7274.6 BM5×70	1
11	10001177	Emergency down cable assembly (JCPT0808HA/AC, JCPT0812HA/AC, JCPT1008HA/AC, JCPT1012HA/AC, JCPT1212HA/AC, JCPT1412HA/AC, JCPT1612HAS/ACS)	1
	10011006	Emergency down cable assembly (JCPT1612HA/AC, JCPT1614HA/AC)	1
12	00001054	Screw GB/T 70.1 M4×12	1
13	10000413	Cable connector	1
14	00003020	Nut	1
15	00003019	Coil	1
16	00003022	Solenoid valve spool	1
17	00000876	Screw GB/T 70.1 M6×16	2

**401.1 Lower Lift Cylinder Assembly**

Item	Part No.	Description	Qty.
18	00000621	Washer GB/T 93 6	2
19	00000620	Washer GB/T 97.1 6	2
20	10000431	Valve cover	1
21	10000462	Nut	1
22	10000464	Fitting	1
23	00002519	Washer BS/A 13.74	2
24	10000465	Fitting	1
25	00003026	Seal kit (JCPT0808HA/AC, JCPT0812HA/AC, JCPT1008HA/AC, JCPT1012HA/AC, JCPT1212HA/AC, JCPT1412HA/AC)	1
	00004635	Seal kit (JCPT1612HA/AC, JCPT1614HA/AC)	1
	00004829	Seal kit (JCPT1612HAS/ACS)	1

**402.1 Upper Lift Cylinder Assembly**

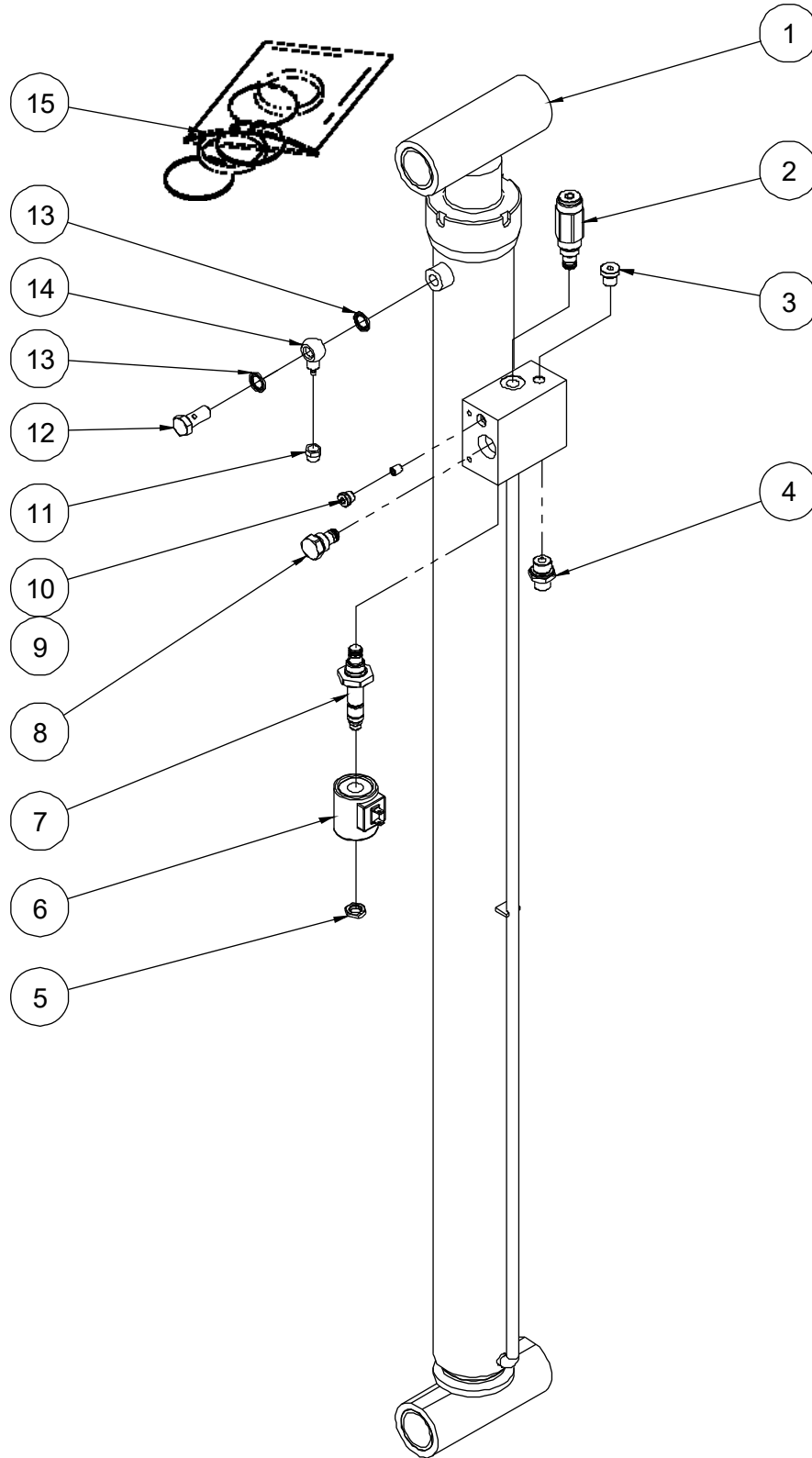

**402.1 Upper Lift Cylinder Assembly**

Item	Part No.	Description	Qty.
1	10000448	Upper lift cylinder (JCPT1212HA/AC, JCPT1412HA/AC, JCPT1612HAS/ACS)	1
	10020362	Upper lift cylinder (JCPT1612HA/AC, JCPT1614HA/AC)	1
2	10000086	Relief valve	1
3	00001073	Plug VST114×1.5ED	1
4	00001292	Straight fitting	1
5	00003017	Nut	1
6	00003018	Coil	1
7	00004686	Solenoid valve spool	1
8	10000404	Check valve	1
9	00003000	Orifice $\Phi 1.0$ (JCPT1212HA/AC, JCPT1412HA/AC, JCPT1612HAS/ACS)	1
	00003578	Orifice $\Phi 0.8$ (JCPT1612HA/AC, JCPT1614HA/AC)	1
10	00002998	Plug SAE4	1
11	10000462	Nut	1
12	10000464	Fitting	1
13	00002519	Washer BS/A 13.74	2
14	10000465	Fitting	1
15	00003025	Seal kit	1

**403.1 Function manifold (Hydraulic Motor Drive)**

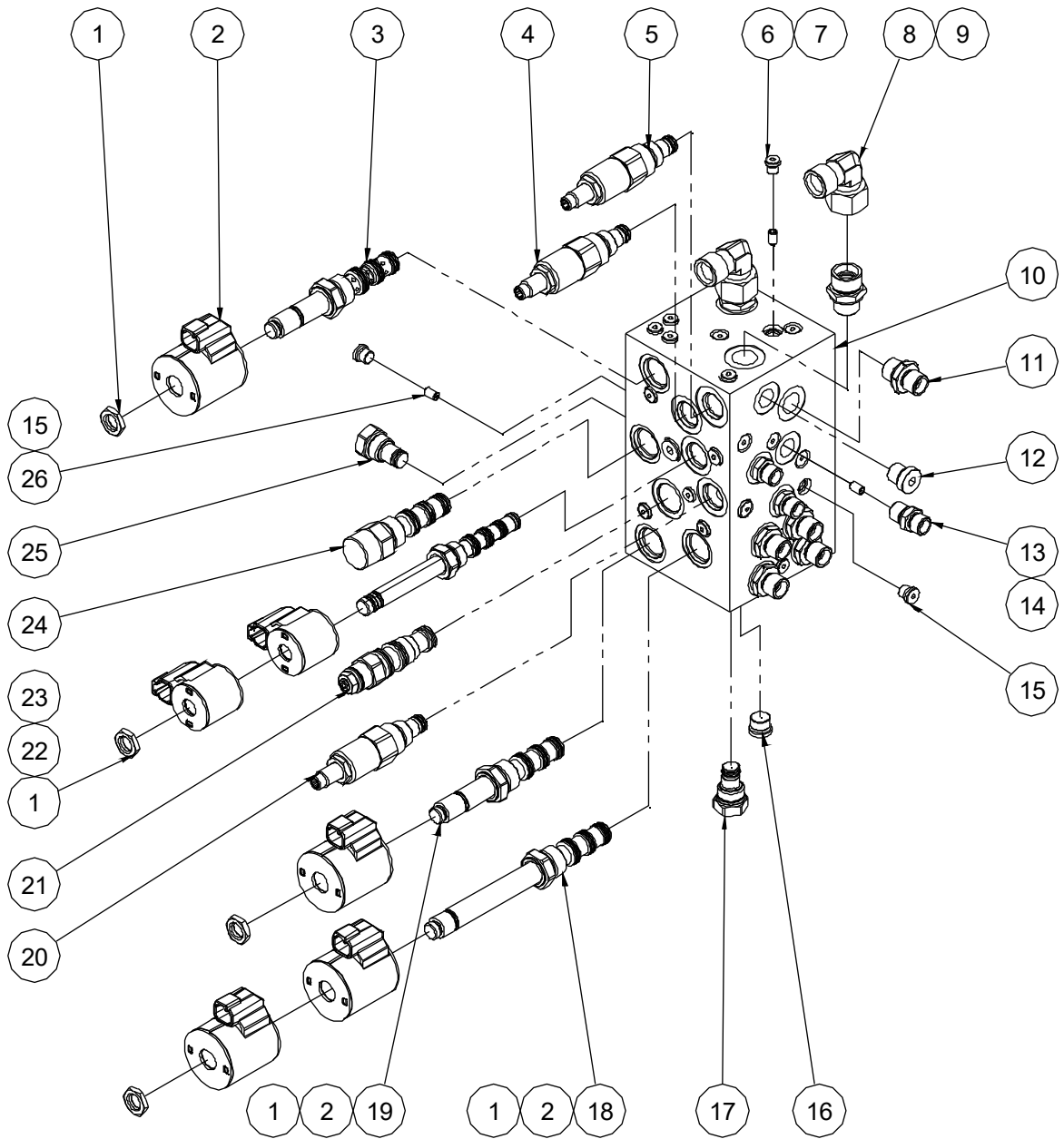

**403.1 Function manifold (Hydraulic Motor Drive)**

Item	Part No.	Description	Qty.
1	00003017	Nut	4
2	00006793	Coil	4
3	00003003	Solenoid valve spool (SV2)	1
4	00006792	Relief valve (RV2)	1
5	00006791	Relief valve (RV1)	1
6	00002999	Plug SAE2	24
7	00006934	Orifice M6_Φ0.8	1
8	00001835	Elbow	2
9	00001264	Straight fitting	2
10	00006790	Valve body	1
11	00001291	Straight fitting	5
12	00001073	Plug VST114×1.5ED	1
13	00001282	Straight fitting	3
14	00006935	Orifice M6_Φ1.3	2
15	00002997	Plug SAE3	11
16	00003361	Plug SAE6	2
17	10000404	Check valve (CV1)	1
18	00003011	Solenoid valve spool (SV4)	1
19	00003010	Solenoid valve spool (SV3)	1
20	00007654	Relief valve (RV3)	1
21	00008022	Counterbalance valve spool (CB1)	1
22	00006770	Coil	2
23	00006789	Solenoid valve spool (SV1)	1
24	00006785	Flow control valve (EC1)	1
25	00006786	Check valve (CV2)	1
26	00006936	Orifice M6_Φ1.5	1

**404.1 Function manifold (Electric Motor Drive)**

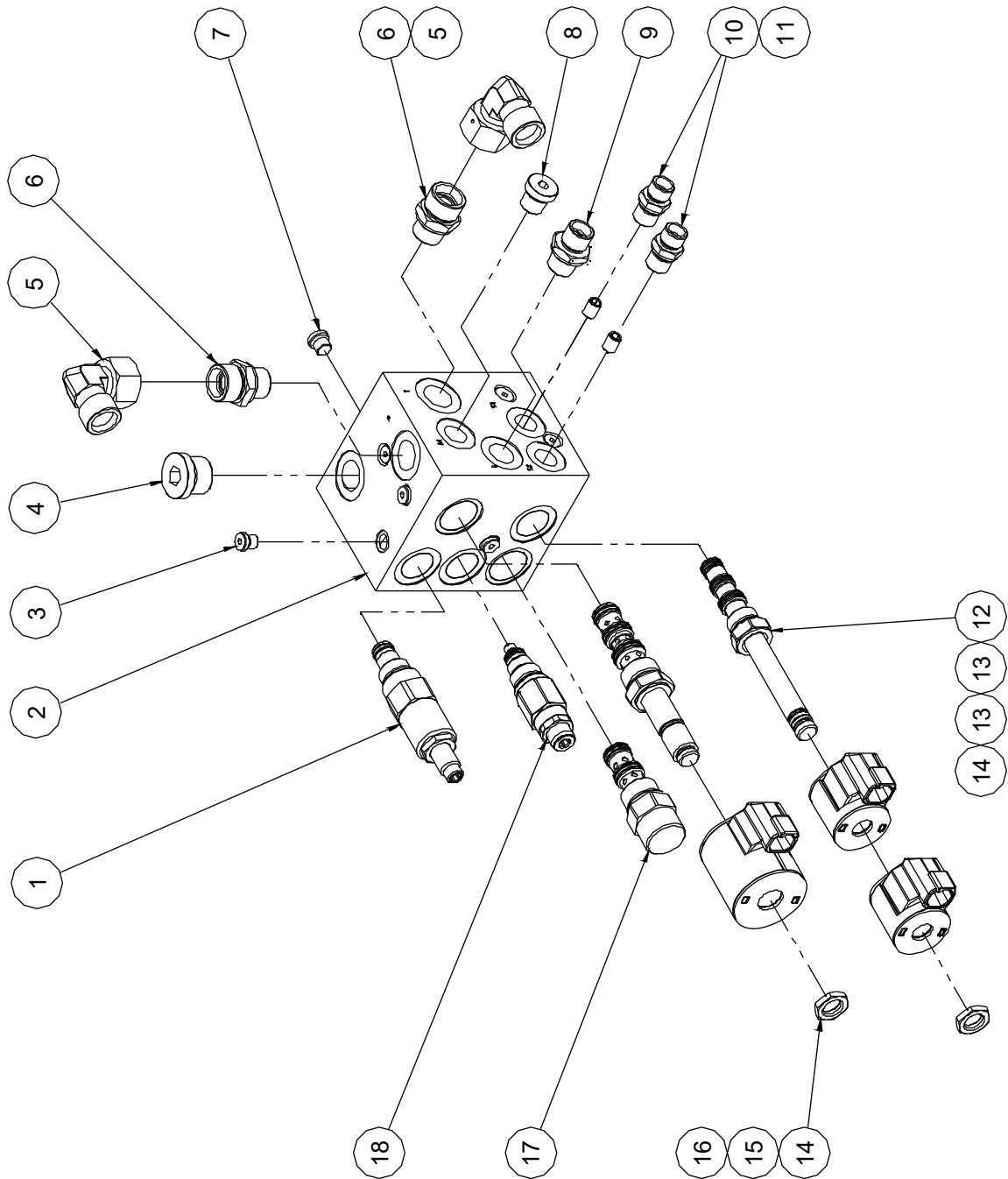

**404.1 Function manifold (Electric Motor Drive)**

Item	Part No.	Description	Qty.
1	00006792	Relief valve (RV1)	1
2	00007753	Valve body	1
3	00002999	Plug SAE2	13
4	00001077	Plug VST122×1.5ED	1
5	00001835	Elbow	2
6	00001264	Straight fitting	2
7	00002997	Plug SAE3	3
8	00001073	Plug VST114×1.5ED	1
9	00001291	Straight fitting	1
10	00001282	Straight fitting	2
11	00003000	Orifice $\Phi 1.0$	2
12	00003004	Solenoid valve spool (SV1)	1
13	00006770	Coil	2
14	00003017	Nut	2
15	00006793	Coil	1
16	00003003	Solenoid valve spool (SV2)	1
17	00003012	Flow control valve (FR1)	1
18	00007654	Relief valve (RV2)	1

**405.1 Hydraulic Hoses and Fittings (JCPT0808HA, JCPT0812HA, JCPT1008HA, JCPT1012HA)**

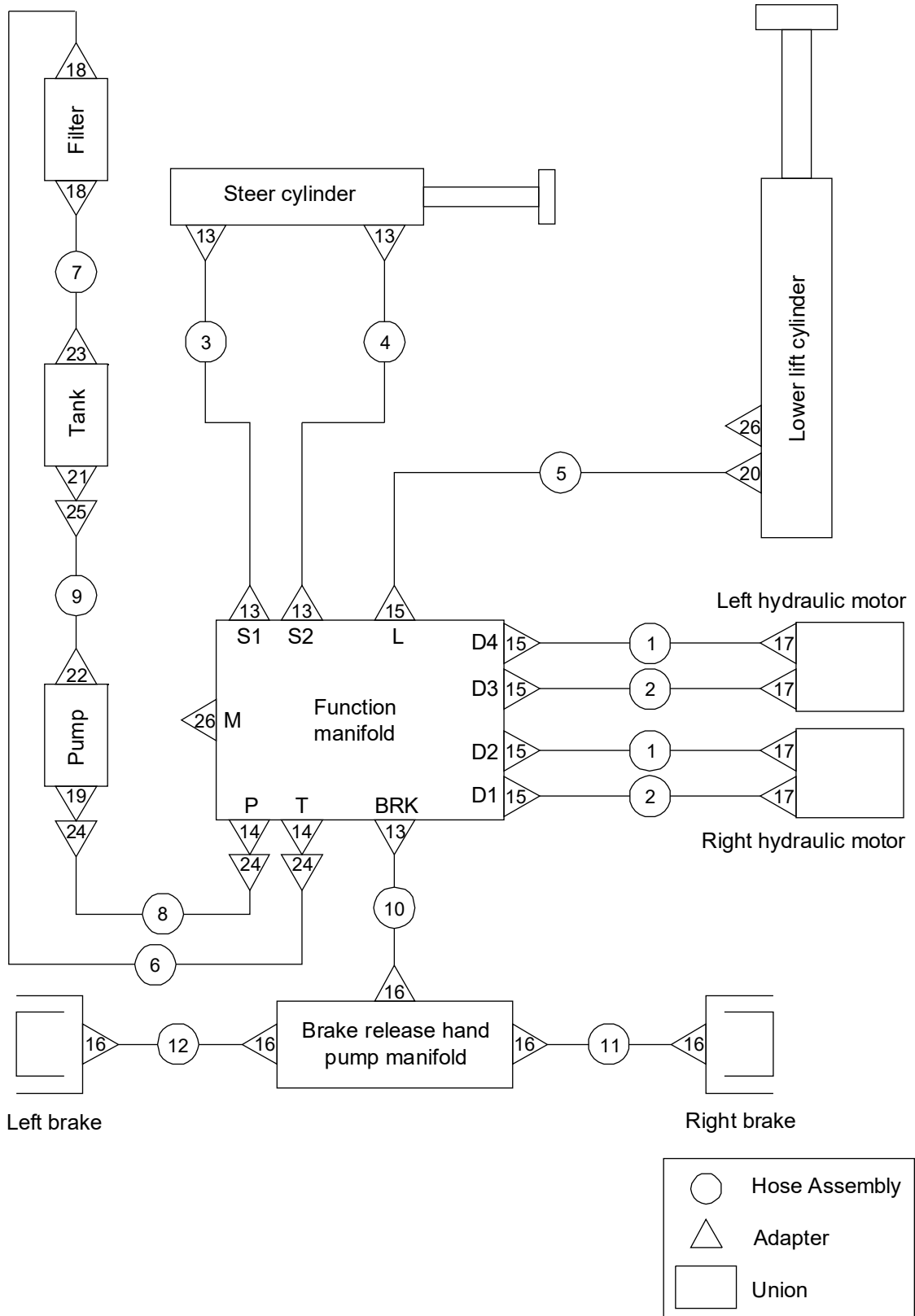

### 405.1 Hydraulic Hoses and Fittings (JCPT0808HA, JCPT0812HA, JCPT1008HA, JCPT1012HA)

Item	Part No.	Description	Qty.
1	00002278	Hose assembly (JCPT0808HA, JCPT1008HA)	2
	00002187	Hose assembly (JCPT0812HA, JCPT1012HA)	2
2	00002279	Hose assembly (JCPT0808HA, JCPT1008HA)	2
	00002188	Hose assembly (JCPT0812HA, JCPT1012HA)	2
3	00002280	Hose assembly (JCPT0808HA, JCPT1008HA)	1
	00002189	Hose assembly (JCPT0812HA, JCPT1012HA)	1
4	00002281	Hose assembly (JCPT0808HA, JCPT1008HA)	1
	00002190	Hose assembly (JCPT0812HA, JCPT1012HA)	1
5	00002192	Hose assembly	1
6	00007797	Hose assembly	1
7	00002194	Hose assembly	1
8	00002195	Hose assembly	1
9	00006927	Hose assembly	1
10	00002282	Hose assembly (JCPT0808HA, JCPT1008HA)	1
	00002197	Hose assembly (JCPT0812HA, JCPT1012HA)	1
11	00002284	Hose assembly (JCPT0808HA, JCPT1008HA)	1
	00002198	Hose assembly (JCPT0812HA, JCPT1012HA)	1
12	00002283	Hose assembly (JCPT0808HA, JCPT1008HA)	1
	00002199	Hose assembly (JCPT0812HA, JCPT1012HA)	1
13	00001282	Straight fitting	5
14	00001264	Straight fitting	2
15	00001291	Straight fitting	5
16	00001769	Straight fitting	5
17	00001771	Straight fitting	4
18	00001508	Straight fitting	2
19	00001776	Straight fitting	1
20	00001292	Straight fitting	1
21	00001268	Straight fitting	1

**405.1 Hydraulic Hoses and Fittings (JCPT0808HA,  
JCPT0812HA, JCPT1008HA, JCPT1012HA)**

<b>Item</b>	<b>Part No.</b>	<b>Description</b>	<b>Qty.</b>
22	00001778	Straight fitting	1
23	10000466	Fitting	1
24	00001835	Elbow	3
25	00006447	Elbow	1
26	00001073	Plug VSTI14×1.5ED	2

**406.1 Hydraulic Hoses and Fittings (JCPT0808AC, JCPT0812AC, JCPT1008AC, JCPT1012AC)**

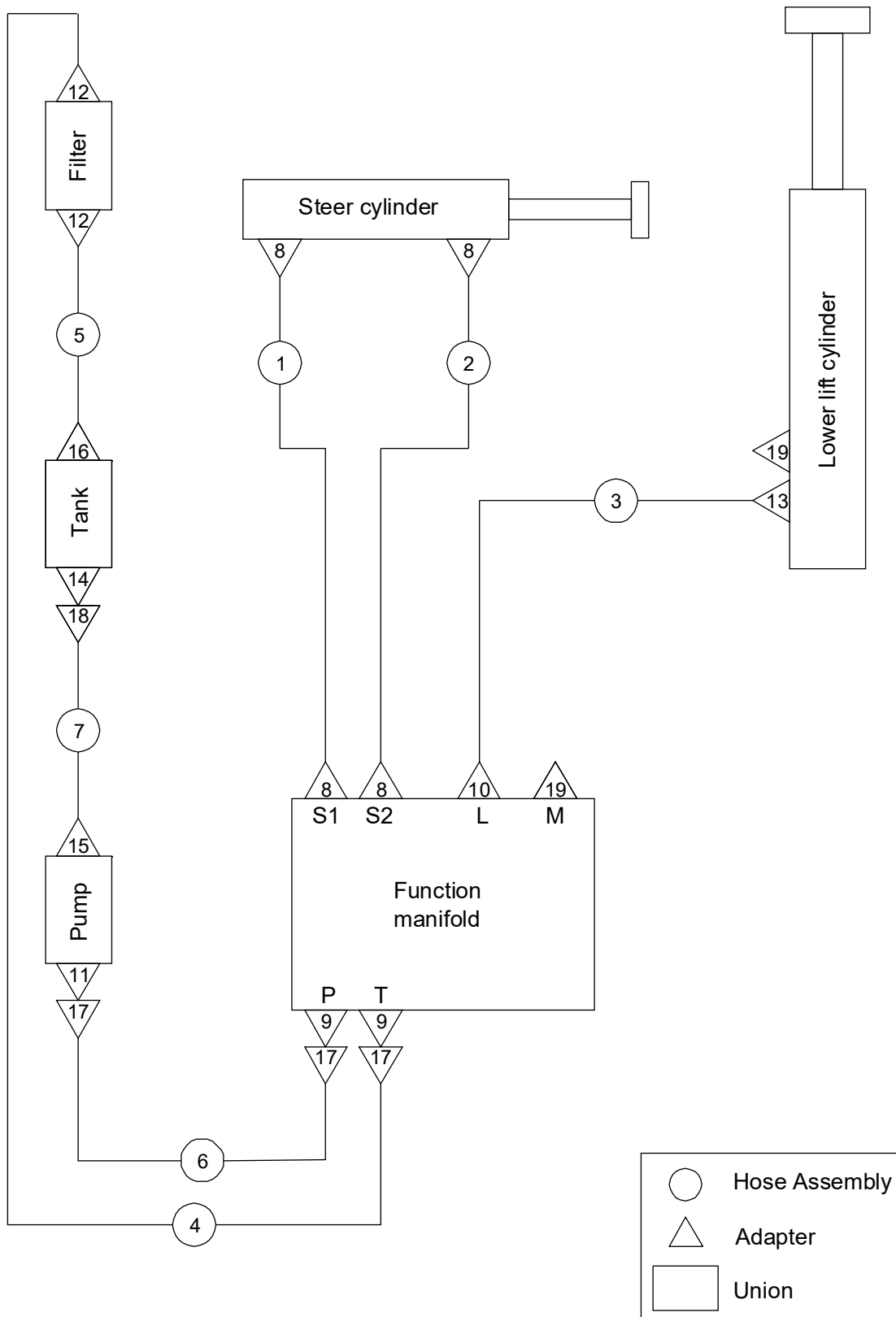

### 406.1 Hydraulic Hoses and Fittings (JCPT0808AC, JCPT0812AC, JCPT1008AC, JCPT1012AC)

Item	Part No.	Description	Qty.
1	00002280	Hose assembly (JCPT0808AC, JCPT1008AC)	1
	00002189	Hose assembly (JCPT0812AC, JCPT1012AC)	1
2	00002281	Hose assembly (JCPT0808AC, JCPT1008AC)	1
	00002190	Hose assembly (JCPT0812AC, JCPT1012AC)	1
3	00002192	Hose assembly	1
4	00002276	Hose assembly	1
5	00002194	Hose assembly	1
6	00002277	Hose assembly	1
7	00006927	Hose assembly	1
8	00001282	Straight fitting	4
9	00001264	Straight fitting	2
10	00001291	Straight fitting	1
11	00001776	Straight fitting	1
12	00001508	Straight fitting	2
13	00001292	Straight fitting	1
14	00001268	Straight fitting	1
15	00001778	Straight fitting	1
16	10000466	Fitting	1
17	00001835	Elbow	3
18	00006447	Elbow	1
19	00001073	Plug VSTI14×1.5ED	2

**407.1 Hydraulic Hoses and Fittings (JCPT1212HA, JCPT1412HA, JCPT1612HAS)**

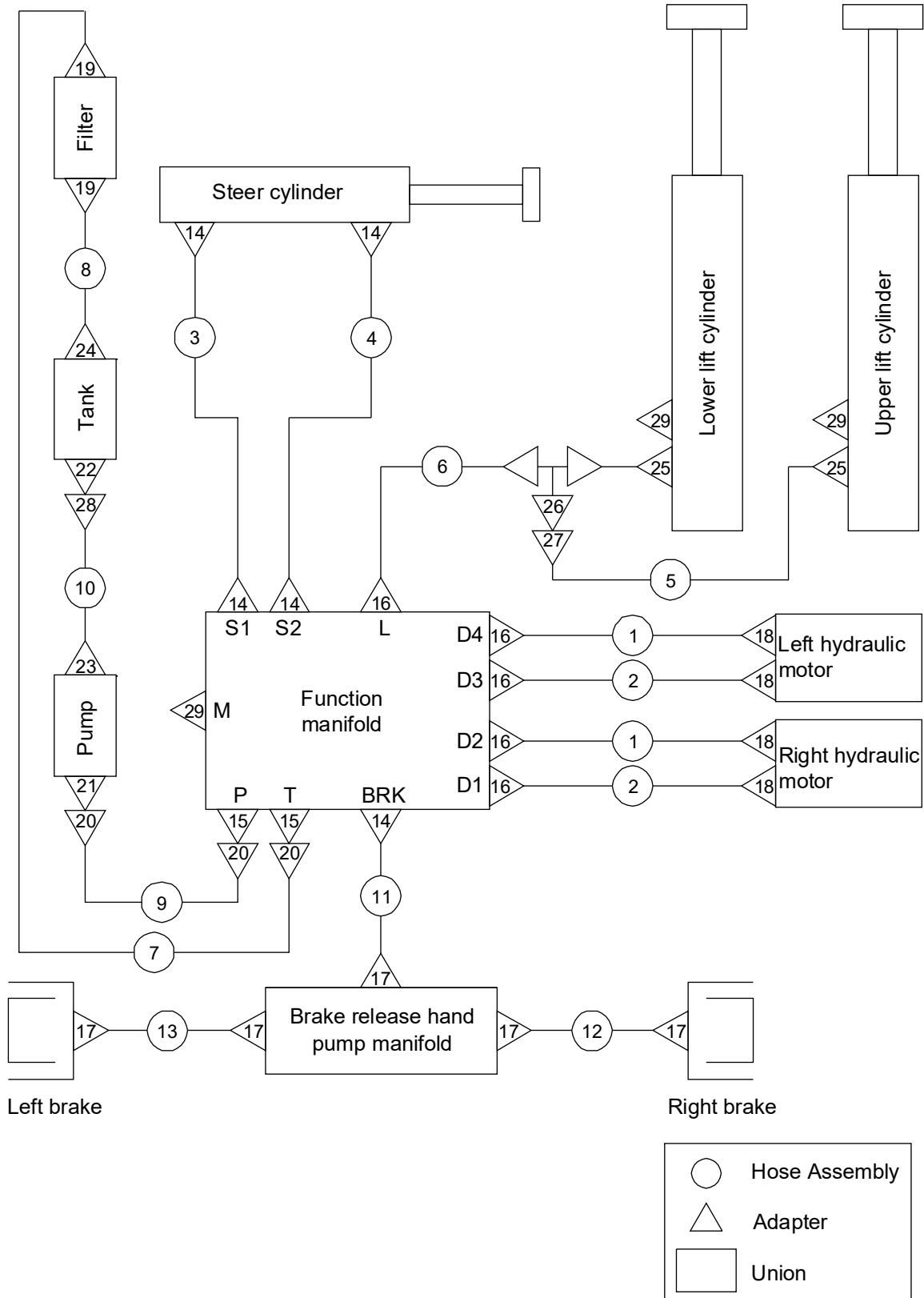

### 407.1 Hydraulic Hoses and Fittings (JCPT1212HA, JCPT1412HA, JCPT1612HAS)

Item	Part No.	Description	Qty.
1	00002187	Hose assembly	2
2	00002188	Hose assembly	2
3	00002189	Hose assembly	1
4	00002190	Hose assembly	1
5	00002191	Hose assembly (JCPT1212HA, JCPT1412HA)	1
	00005411	Hose assembly (JCPT1612HAS)	1
6	00002192	Hose assembly	1
7	00007797	Hose assembly	1
8	00002194	Hose assembly	1
9	00002195	Hose assembly	1
10	00006927	Hose assembly	1
11	00002197	Hose assembly	1
12	00002198	Hose assembly	1
13	00002199	Hose assembly	1
14	00001282	Straight fitting	5
15	00001264	Straight fitting	2
16	00001291	Straight fitting	5
17	00001769	Straight fitting	5
18	00001771	Straight fitting	4
19	00001508	Straight fitting	2
20	00001835	Elbow	3
21	00001776	Straight fitting	1
22	00001268	Straight fitting	1
23	00001778	Straight fitting	1
24	10000466	Fitting	1
25	00001292	Straight fitting	2
26	00001238	Tee fitting	1
27	00001833	Elbow	1

**407.1 Hydraulic Hoses and Fittings (JCPT1212HA, JCPT1412HA,  
JCPT1612HAS)**

<b>Item</b>	<b>Part No.</b>	<b>Description</b>	<b>Qty.</b>
28	00006447	Elbow	1
29	00001073	Plug VST114×1.5ED	3

**408.1 Hydraulic Hoses and Fittings (JCPT1212AC, JCPT1412AC, JCPT1612ACS)**

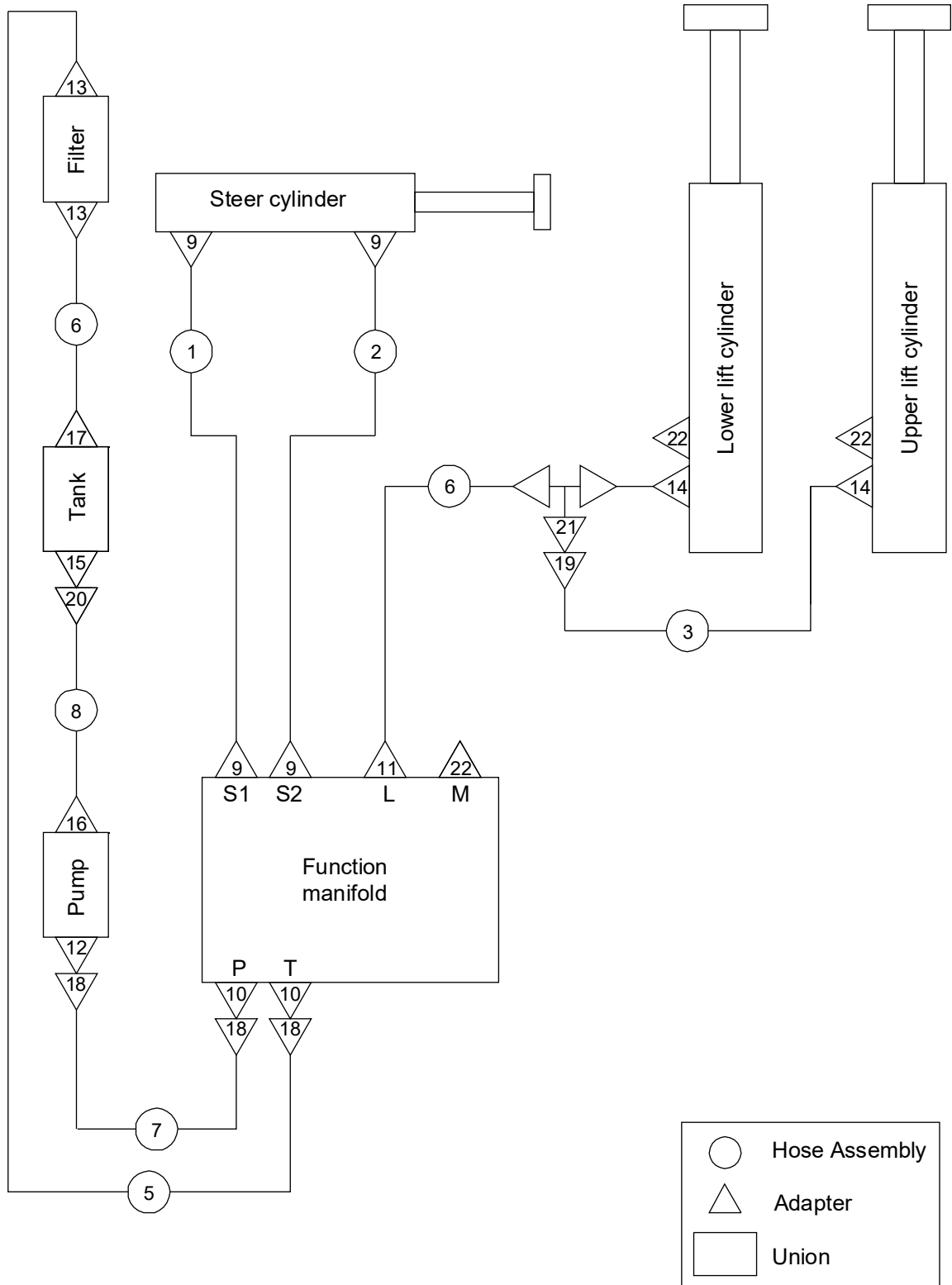

### 408.1 Hydraulic Hoses and Fittings (JCPT1212AC, JCPT1412AC, JCPT1612ACS)

Item	Part No.	Description	Qty.
1	00002189	Hose assembly	1
2	00002190	Hose assembly	1
3	00002191	Hose assembly (JCPT1212AC, JCPT1412AC)	1
	00005411	Hose assembly (JCPT1612ACS)	1
4	00002192	Hose assembly	1
5	00002276	Hose assembly	1
6	00002194	Hose assembly	1
7	00002277	Hose assembly	1
8	00006927	Hose assembly	1
9	00001282	Straight fitting	4
10	00001264	Straight fitting	2
11	00001291	Straight fitting	1
12	00001776	Straight fitting	1
13	00001508	Straight fitting	2
14	00001292	Straight fitting	2
15	00001268	Straight fitting	1
16	00001778	Straight fitting	1
17	10000466	Fitting	1
18	00001835	Elbow	3
19	00001833	Elbow	1
20	00006447	Elbow	1
21	00001238	Tee fitting	1
22	00001073	Plug VST114×1.5ED	3

**409.1 Hydraulic Hoses and Fittings (JCPT1612HA, JCPT1614HA)**

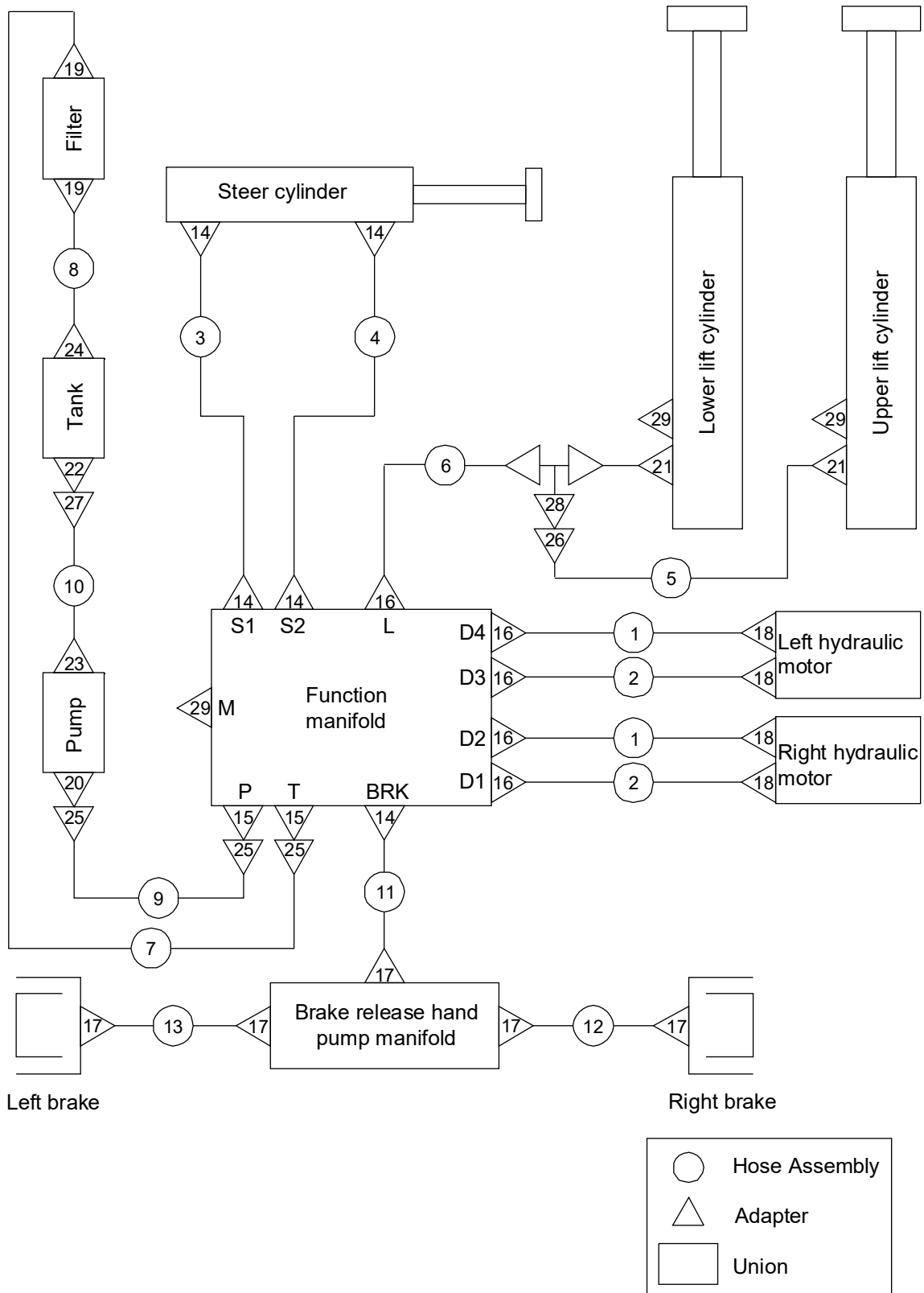

**409.1 Hydraulic Hoses and Fittings (JCPT1612HA, JCPT1614HA)**

Item	Part No.	Description	Qty.
1	00002292	Hose assembly (JCPT1612HA)	2
	00002293	Hose assembly (JCPT1614HA)	2
2	00002293	Hose assembly (JCPT1612HA)	2
	00002753	Hose assembly (JCPT1614HA)	2
3	00002288	Hose assembly (JCPT1612HA)	1
	00002295	Hose assembly (JCPT1614HA)	1
4	00002287	Hose assembly (JCPT1612HA)	1
	00002294	Hose assembly (JCPT1614HA)	1
5	00005172	Hose assembly	1
6	00005173	Hose assembly	1
7	00002193	Hose assembly	1
8	00002194	Hose assembly	1
9	00002277	Hose assembly	1
10	00006927	Hose assembly	1
11	00002289	Hose assembly	1
12	00002291	Hose assembly	1
13	00002290	Hose assembly	1
14	00001282	Straight fitting	5
15	00001264	Straight fitting	2
16	00001291	Straight fitting	5
17	00001769	Straight fitting	5
18	00001771	Straight fitting	4
19	00001508	Straight fitting	2
20	00001776	Straight fitting	1
21	00001292	Straight fitting	2
22	00001268	Straight fitting	1
23	00001778	Straight fitting	1
24	10000466	Fitting	1
25	00001835	Elbow	3

**409.1 Hydraulic Hoses and Fittings (JCPT1612HA, JCPT1614HA)**

<b>Item</b>	<b>Part No.</b>	<b>Description</b>	<b>Qty.</b>
26	00001833	Elbow	1
27	00006447	Elbow	1
28	00001238	Tee fitting	1
29	00001073	Plug VSTI14×1.5ED	3

**410.1 Hydraulic Hoses and Fittings (JCPT1612AC, JCPT1614AC)**

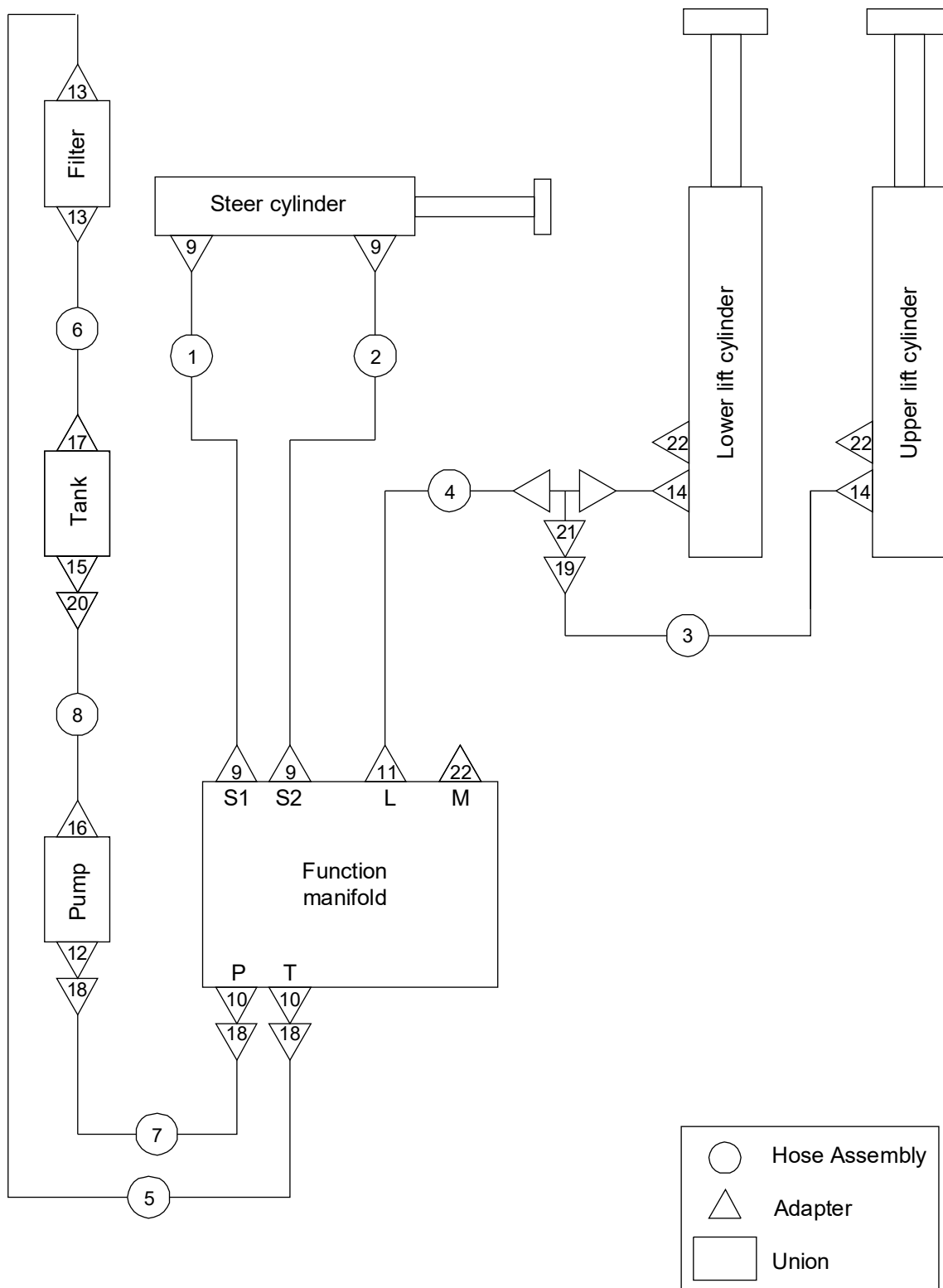

**410.1 Hydraulic Hoses and Fittings (JCPT1612AC, JCPT1614AC)**

Item	Part No.	Description	Qty.
1	00002288	Hose assembly (JCPT1612AC)	1
	00002295	Hose assembly (JCPT1614AC)	1
2	00002287	Hose assembly (JCPT1612AC)	1
	00002294	Hose assembly (JCPT1614AC)	1
3	00005172	Hose assembly	1
4	00005173	Hose assembly	1
5	00006986	Hose assembly	1
6	00002194	Hose assembly	1
7	00007946	Hose assembly	1
8	00006927	Hose assembly	1
9	00001282	Straight fitting	4
10	00001264	Straight fitting	2
11	00001291	Straight fitting	1
12	00001776	Straight fitting	1
13	00001508	Straight fitting	2
14	00001292	Straight fitting	2
15	00001268	Straight fitting	1
16	00001778	Straight fitting	1
17	10000466	Fitting	1
18	00001835	Elbow	3
19	00001833	Elbow	1
20	00006447	Elbow	1
21	00001238	Tee fitting	1
22	00001073	Plug VST114×1.5ED	3

# **Section 5 Electrical System**

**501.1 Electrical Harness (Hydraulic Motor Drive) (Lead-acid Battery)**

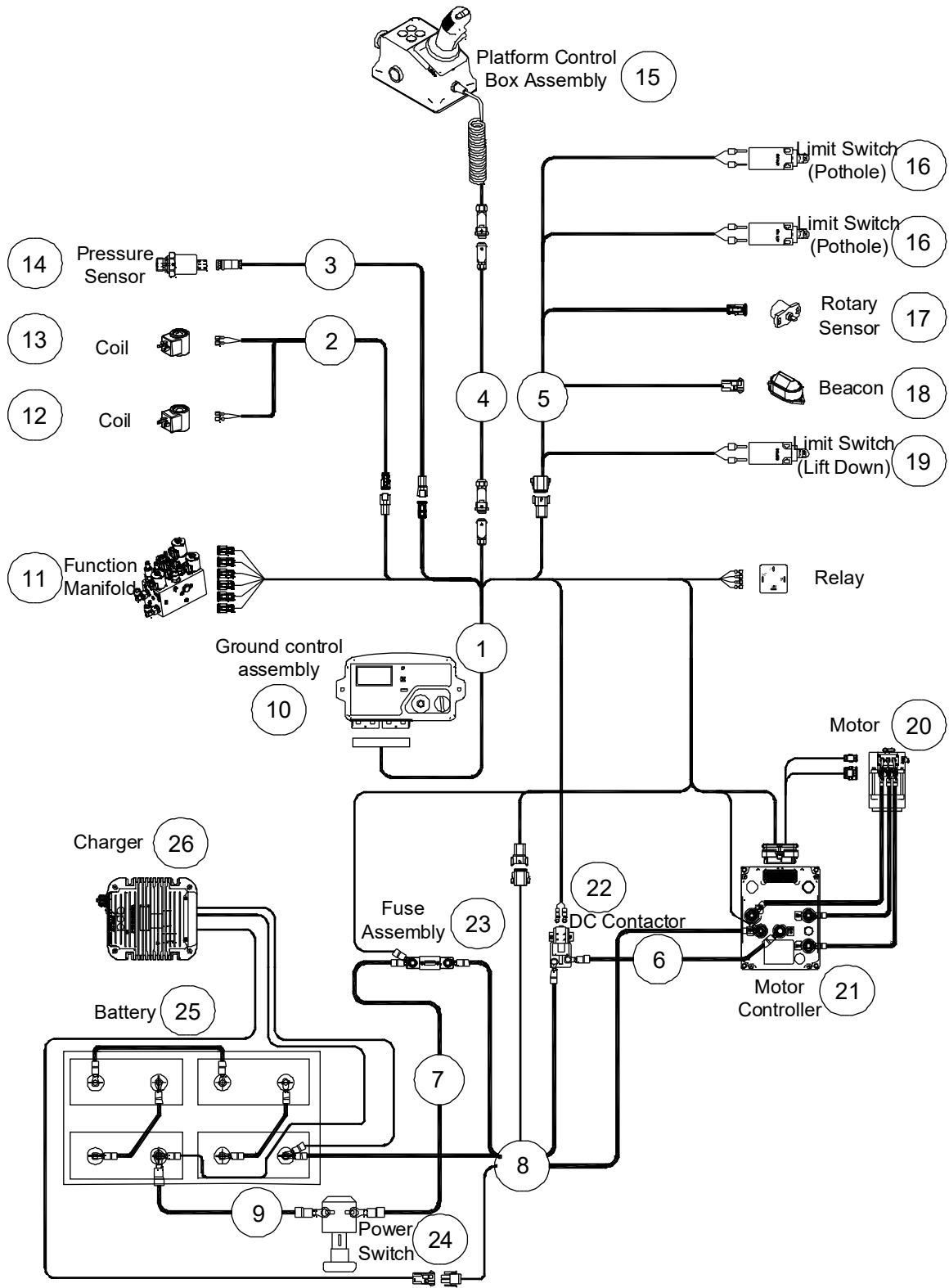

### 501.1 Electrical Harness (Hydraulic Motor Drive) (Lead-acid Battery)

Item	Part No.	Description	Qty.
1	00008020	ECU Harness	1
2	00008038	Lowering valve harness (JCPT0808HA, JCPT0812HA, JCPT1008HA, JCPT1012HA)	1
	00008037	Lowering valve harness (JCPT1212HA, JCPT1412HA)	1
	00008586	Lowering valve harness (JCPT1612HAS)	1
	00008039	Lowering valve harness (JCPT1612HA, JCPT1614HA)	1
3	00008040	Pressure sensor harness (JCPT0808HA, JCPT0812HA, JCPT1008HA, JCPT1012HA, JCPT1212HA, JCPT1412HA, JCPT1612HAS) (matching with 00007393 pressure sensor)	1
	00008373	Pressure sensor harness (JCPT0808HA, JCPT0812HA, JCPT1008HA, JCPT1012HA, JCPT1212HA, JCPT1412HA, JCPT1612HAS) (matching with 00000696 pressure sensor)	1
	00008041	Pressure sensor harness (JCPT1612HA, JCPT1614HA) (matching with 00007393 pressure sensor)	1
	00008375	Pressure sensor harness (JCPT1612HA, JCPT1614HA) (matching with 00000696 pressure sensor)	1
4	00007728	Platform control box harness (JCPT0808HA)	1
	00008450	Platform control box harness (JCPT0812HA)	1
	00007726	Platform control box harness (JCPT1008HA)	1
	00007722	Platform control box harness (JCPT1012HA)	1
	00007705	Platform control box harness (JCPT1212HA)	1
	00007701	Platform control box harness (JCPT1412HA)	1
	00007716	Platform control box harness (JCPT1612HA, JCPT1614HA)	1
	00008547	Platform control box harness (JCPT1612HAS)	1
5	00008036	Limit switch harness (JCPT0808HA, JCPT1008HA)	1
	00008035	Limit switch harness (JCPT0812HA, JCPT1012HA, JCPT1212HA, JCPT1412HA, JCPT1612HAS)	1
	00008034	Limit switch harness (JCPT1612HA, JCPT1614HA)	1
6	00007496	Power harness	1
7	00007677	Power harness	1

### 501.1 Electrical Harness (Hydraulic Motor Drive) (Lead-acid Battery)

Item	Part No.	Description	Qty.
8	00008058	Battery harness (JCPT0808HA, JCPT1008HA)	1
	00008029	Battery harness (JCPT0812HA, JCPT1012HA, JCPT1212HA, JCPT1412HA, JCPT1612HAS)	1
	00008027	Battery harness (JCPT1612HA, JCPT1614HA)	1
9	00007356	Power harness	1
10	00007543	Ground control assembly (without IOT module)	1
	00006801	Ground control assembly (with IOT module)	1
11	00006788	Function manifold	1
12	00003019	Coil	1
13	00003018	Coil (JCPT1212HA, JCPT1412HA, JCPT1612HA, JCPT1612HAS, JCPT1614HA)	1
14	00007393	Pressure sensor (current signal)	1
	00000696	Pressure sensor (voltage signal)	1
15	00006872	Platform control box assembly	1
16	00007930	Limit switch, pothole	2
17	00004796	Rotary sensor	1
18	00000740	Beacon	1
19	00007932	Limit switch, lift down	1
20	00007927	Motor	1
21	00006263	Motor controller	1
22	00006900	DC Contactor	1
23	00007674	250A Fuse assembly	1
24	00000655	Power switch	1
25	00008417	Battery (JCPT0808HA, JCPT0812HA, JCPT1008HA, JCPT1012HA)	4
	00008416	Battery (JCPT1212HA) (Need to install the liner 10018772)	4
	00008412	Battery (JCPT1412HA, JCPT1612HA JCPT1612HAS, JCPT1614HA)	4
26	00000689	Charger (GPSC)	1
	00007684	Charger (EPC)	1

### 501.2 Electrical harness (Hydraulic Motor Drive) (Lithium Battery)

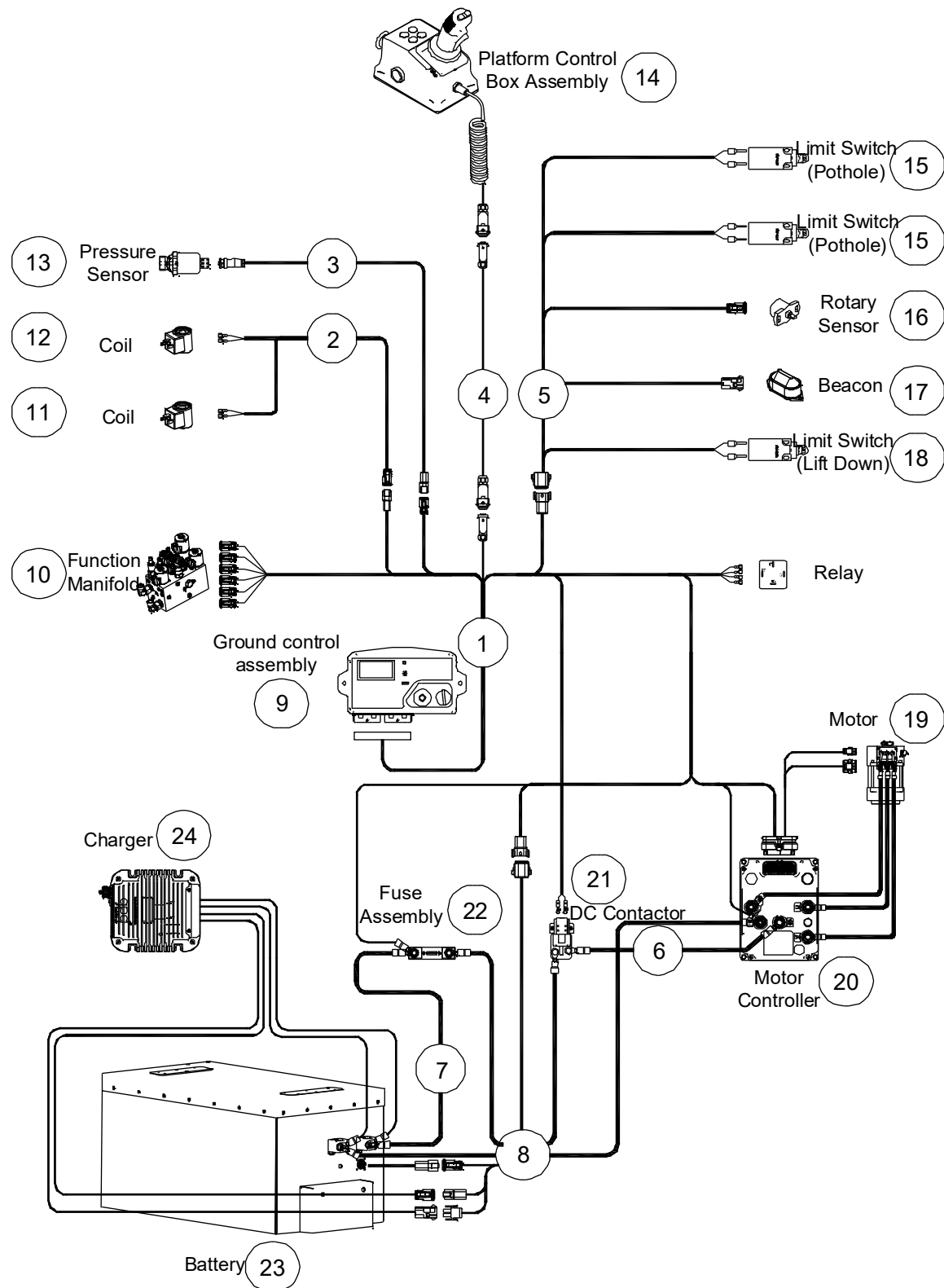

## 501.2 Electrical harness (Hydraulic Motor Drive) (Lithium Battery)

Item	Part No.	Description	Qty.
1	00008020	ECU Harness	1
2	00008038	Lowering valve harness (JCPT0808HA, JCPT0812HA, JCPT1008HA, JCPT1012HA)	1
	00008037	Lowering valve harness (JCPT1212HA, JCPT1412HA)	1
	00008586	Lowering valve harness (JCPT1612HAS)	1
	00008039	Lowering valve harness (JCPT1612HA, JCPT1614HA)	1
3	00008040	Pressure sensor harness (JCPT0808HA, JCPT0812HA, JCPT1008HA, JCPT1012HA, JCPT1212HA, JCPT1412HA, JCPT1612HAS) (matching with 00007393 pressure sensor)	1
	00008373	Pressure sensor harness (JCPT0808HA, JCPT0812HA, JCPT1008HA, JCPT1012HA, JCPT1212HA, JCPT1412HA, JCPT1612HAS) (matching with 00000696 pressure sensor)	1
	00008041	Pressure sensor harness (JCPT1612HA, JCPT1614HA) (matching with 00007393 pressure sensor)	1
	00008375	Pressure sensor harness (JCPT1612HA, JCPT1614HA) (matching with 00000696 pressure sensor)	1
4	00007728	Platform control box harness (JCPT0808HA)	1
	00008450	Platform control box harness (JCPT0812HA)	1
	00007726	Platform control box harness (JCPT1008HA)	1
	00007722	Platform control box harness (JCPT1012HA)	1
	00007705	Platform control box harness (JCPT1212HA)	1
	00007701	Platform control box harness (JCPT1412HA)	1
	00007716	Platform control box harness (JCPT1612HA, JCPT1614HA)	1
	00008547	Platform control box harness (JCPT1612HAS)	1
5	00008036	Limit switch harness (JCPT0808HA, JCPT1008HA)	1
	00008035	Limit switch harness (JCPT0812HA, JCPT1012HA, JCPT1212HA, JCPT1412HA, JCPT1612HAS)	1
	00008034	Limit switch harness (JCPT1612HA, JCPT1614HA)	1
6	00007469	Power harness	1
7	00007763	Power harness	1

## 501.2 Electrical harness (Hydraulic Motor Drive) (Lithium Battery)

Item	Part No.	Description	Qty.
8	00008059	Battery harness (JCPT0808HA, JCPT1008HA)	1
	00008049	Battery harness (JCPT0812HA, JCPT1012HA, JCPT1212HA, JCPT1412HA, JCPT1612HAS)	1
	00008047	Battery harness (JCPT1612HA, JCPT1614HA)	1
9	00007543	Ground control assembly (without IOT module)	1
	00006801	Ground control assembly (with IOT module)	1
10	00006788	Function manifold	1
11	00003019	Coil	1
12	00003018	Coil (JCPT1212HA, JCPT1412HA, JCPT1612HA, JCPT1612HAS, JCPT1614HA)	1
13	00007393	Pressure sensor (current signal)	1
	00000696	Pressure sensor (voltage signal)	1
14	00006872	Platform control box assembly	1
15	00007930	Limit switch, pothole	2
16	00004796	Rotary sensor	1
17	00000740	Beacon	1
18	00007932	Limit switch, lift down	1
19	00007927	Motor	1
20	00006263	Motor controller	1
21	00006900	DC Contactor	1
22	00007674	250A Fuse assembly	1
23	00007777	Battery (JCPT0808HA, JCPT0812HA, JCPT1008HA, JCPT1012HA)	1
	00007778	Battery (JCPT1212HA, JCPT1412HA, JCPT1612HA, JCPT1612HAS, JCPT1614HA)	1
24	00000689	Charger (GPSC)	1
	00007684	Charger (EPC)	1

**502.1 Electrical harness (Electric Motor Drive) (Lead-acid Battery)**

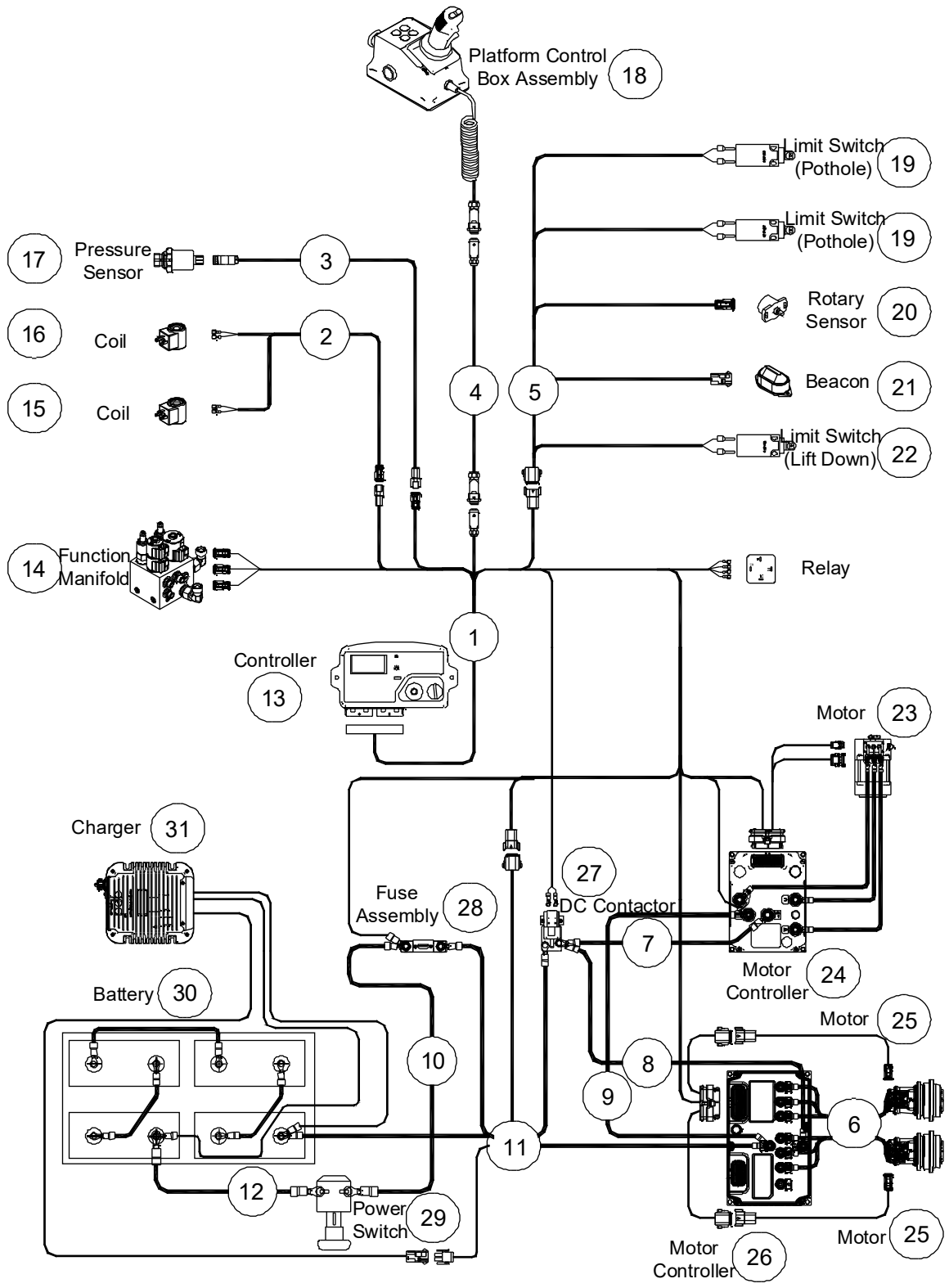

### 502.1 Electrical harness (Electric Motor Drive) (Lead-acid Battery)

Item	Part No.	Description	Qty.
1	00008019	ECU Harness	1
2	00008038	Lowering valve harness (JCPT0808AC, JCPT0812AC, JCPT1008AC, JCPT1012AC)	1
	00008037	Lowering valve harness (JCPT1212AC, JCPT1412AC)	1
	00008586	Lowering valve harness (JCPT1612ACS)	1
	00008039	Lowering valve harness (JCPT1612AC, JCPT1614AC)	1
3	00008040	Pressure sensor harness (JCPT0808AC, JCPT0812AC, JCPT1008AC, JCPT1012AC, JCPT1212AC, JCPT1412AC, JCPT1612ACS) (matching with 00007393 pressure sensor)	1
	00008373	Pressure sensor harness (JCPT0808AC, JCPT0812AC, JCPT1008AC, JCPT1012AC, JCPT1212AC, JCPT1412AC, JCPT1612ACS) (matching with 00000696 pressure sensor)	1
	00008041	Pressure sensor harness (JCPT1612AC, JCPT1614AC) (matching with 00007393 pressure sensor)	1
	00008375	Pressure sensor harness (JCPT1612AC, JCPT1614AC) (matching with 00000696 pressure sensor)	1
4	00007728	Platform control box harness (JCPT0808AC)	1
	00008450	Platform control box harness (JCPT0812AC)	1
	00007726	Platform control box harness (JCPT1008AC)	1
	00007722	Platform control box harness (JCPT1012AC)	1
	00007705	Platform control box harness (JCPT1212AC)	1
	00007701	Platform control box harness (JCPT1412AC)	1
	00007716	Platform control box harness (JCPT1612AC, JCPT1614AC)	1
	00008547	Platform control box harness (JCPT1612ACS)	1
5	00008036	Limit switch harness (JCPT0808AC, JCPT1008AC)	1
	00008035	Limit switch harness (JCPT0812AC, JCPT1012AC, JCPT1212AC, JCPT1412AC, JCPT1612ACS)	1
	00008034	Limit switch harness (JCPT1612AC, JCPT1614AC)	1
6	00008368	Drive motor harness(JCPT0808AC, JCPT1008AC)	1
	00008367	Drive motor harness (JCPT0812AC, JCPT1012AC, JCPT1212AC, JCPT1412AC, JCPT1612ACS)	1
	00008407	Drive motor harness(JCPT1612AC)	1
	00008514	Drive motor harness(JCPT1614AC)	1

### 502.1 Electrical harness (Electric Motor Drive) (Lead-acid Battery)

Item	Part No.	Description	Qty.
7	00007496	Power harness	1
8	00006909	Power harness	1
9	00006912	Power harness	1
10	00007677	Power harness	1
11	00008030	Battery harness (JCPT0808AC, JCPT1008AC)	1
	00008028	Battery harness (JCPT0812AC, JCPT1012AC, JCPT1212AC, JCPT1412AC, JCPT1612ACS)	1
	00008024	Battery harness (JCPT1612AC, JCPT1614AC)	1
12	00007356	Power harness	1
13	00007543	Ground control assembly (without IOT module)	1
	00006801	Ground control assembly (with IOT module)	1
14	00007736	Function manifold	1
15	00003019	Coil	1
16	00003018	Coil (JCPT1212AC, JCPT1412AC, JCPT1612AC, JCPT1612ACS, JCPT1614AC)	1
17	00007393	Pressure sensor (current signal)	1
	00000696	Pressure sensor (voltage signal)	1
18	00006872	Platform control box assembly	1
19	00007930	Limit switch, pothole	2
20	00004796	Rotary sensor	1
21	00000740	Beacon	1
22	00007932	Limit switch, lift down	1
23	00007927	Motor	1
24	00006263	Motor controller	1
25	00007685	Motor	2
26	00006262	Motor controller	1
27	00006900	DC contactor	1
28	00007675	300A Fuse assembly	1
29	00000655	Power switch	1

**502.1 Electrical harness (Electric Motor Drive) (Lead-acid Battery)**

Item	Part No.	Description	Qty.
30	00008417	Battery (JCPT0808AC, JCPT0812AC, JCPT1008AC, JCPT1012AC)	4
	00008416	Battery (JCPT1212AC) (Need to install the liner 10018772)	4
	00008412	Battery (JCPT1412AC, JCPT1612AC, JCPT1612ACS, JCPT1614AC)	4
31	00000689	Charger (GPSC)	1
	00007684	Charger (EPC)	1

**502.2 Electrical harness (Electric Motor Drive) (Lithium Battery)**

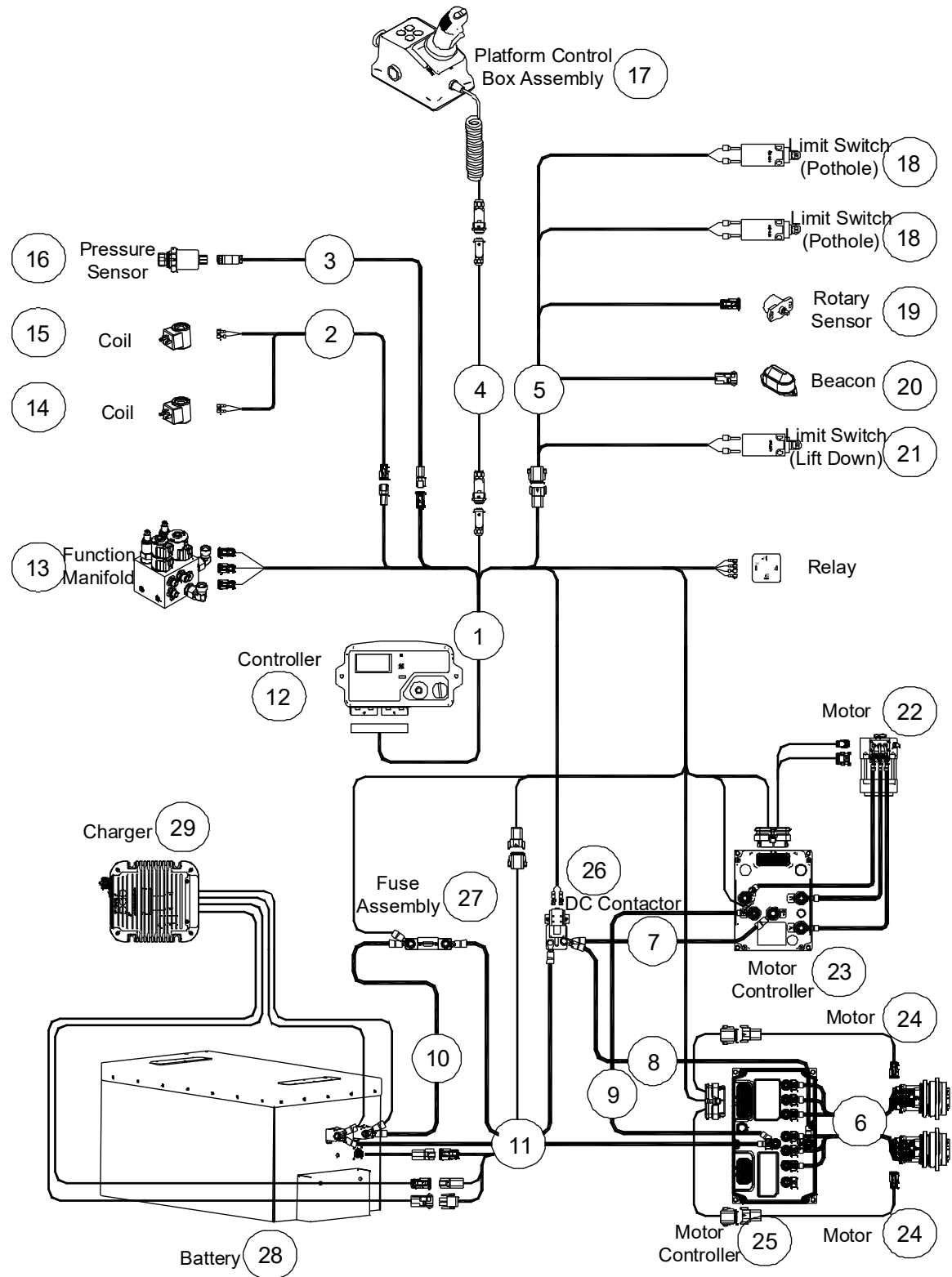

## 502.2 Electrical harness (Electric Motor Drive) (Lithium Battery)

Item	Part No.	Description	Qty.
1	00008019	ECU Harness	1
2	00008038	Lowering valve harness (JCPT0808AC, JCPT0812AC, JCPT1008AC, JCPT1012AC)	1
	00008037	Lowering valve harness (JCPT1212AC, JCPT1412AC)	1
	00008586	Lowering valve harness (JCPT1612ACS)	1
	00008039	Lowering valve harness (JCPT1612AC, JCPT1614AC)	1
3	00008040	Pressure sensor harness (JCPT0808AC, JCPT0812AC, JCPT1008AC, JCPT1012AC, JCPT1212AC, JCPT1412AC, JCPT1612ACS) (matching with 00007393 pressure sensor)	1
	00008373	Pressure sensor harness (JCPT0808AC, JCPT0812AC, JCPT1008AC, JCPT1012AC, JCPT1212AC, JCPT1412AC, JCPT1612ACS) (matching with 00000696 pressure sensor)	1
	00008041	Pressure sensor harness (JCPT1612AC, JCPT1614AC) (matching with 00007393 pressure sensor)	1
	00008375	Pressure sensor harness (JCPT1612AC, JCPT1614AC) (matching with 00000696 pressure sensor)	1
4	00007728	Platform control box harness (JCPT0808AC)	1
	00008450	Platform control box harness (JCPT0812AC)	1
	00007726	Platform control box harness (JCPT1008AC)	1
	00007722	Platform control box harness (JCPT1012AC)	1
	00007705	Platform control box harness (JCPT1212AC)	1
	00007701	Platform control box harness (JCPT1412AC)	1
	00007716	Platform control box harness (JCPT1612AC, JCPT1614AC)	1
	00008547	Platform control box harness (JCPT1612ACS)	1
5	00008036	Limit switch harness (JCPT0808AC, JCPT1008AC )	1
	00008035	Limit switch harness (JCPT0812AC, JCPT1012AC, JCPT1212AC, JCPT1412AC, JCPT1612ACS)	1
	00008034	Limit switch harness (JCPT1612AC, JCPT1614AC)	1
6	00008368	Drive motor harness(JCPT0808AC, JCPT1008AC)	1
	00008367	Drive motor harness (JCPT0812AC, JCPT1012AC, JCPT1212AC, JCPT1412AC, JCPT1612ACS)	1
	00008407	Drive motor harness(JCPT1612AC)	1
	00008514	Drive motor harness(JCPT1614AC)	1

### 502.2 Electrical harness (Electric Motor Drive) (Lithium Battery)

Item	Part No.	Description	Qty.
7	00007496	Power harness	1
8	00006909	Power harness	1
9	00006912	Power harness	1
10	00007763	Power harness	1
11	00008057	Power harness (JCPT0808AC, JCPT1008AC)	1
	00008043	Power harness (JCPT0812AC, JCPT1012AC, JCPT1212AC, JCPT1412AC, JCPT1612ACS)	1
	00008045	Power harness (JCPT1612AC, JCPT1614AC)	1
12	00007543	Ground control assembly (without IOT module)	1
	00006801	Ground control assembly (with IOT module)	1
13	00007736	Function manifold	1
14	00003019	Coil	1
15	00003018	Coil (JCPT1212AC, JCPT1412AC, JCPT1612AC, JCPT1612ACS, JCPT1614AC)	1
16	00007393	Pressure sensor (current signal)	1
	00000696	Pressure sensor (voltage signal)	1
17	00006872	Platform control box assembly	1
18	00007930	Limit switch, pothole	2
19	00004796	Rotary sensor	1
20	00000740	Beacon	1
21	00007932	Limit switch, lift down	1
22	00007927	Motor	1
23	00006263	Motor controller	1
24	00007685	Motor	2
25	00006262	Motor controller	1
26	00006900	DC contactor	1
27	00007675	300A Fuse assembly	1
28	00007777	Battery (JCPT0808AC, JCPT0812AC, JCPT1008AC, JCPT1012AC)	1
	00007778	Battery (JCPT1212AC, JCPT1412AC, JCPT1612AC, JCPT1612ACS, JCPT1614AC)	1

**502.2 Electrical harness (Electric Motor Drive) (Lithium Battery)**

<b>Item</b>	<b>Part No.</b>	<b>Description</b>	<b>Qty.</b>
29	00000689	Charger (GPSC)	1
	00007684	Charger (EPC)	1

### 503.1 Power to Platform

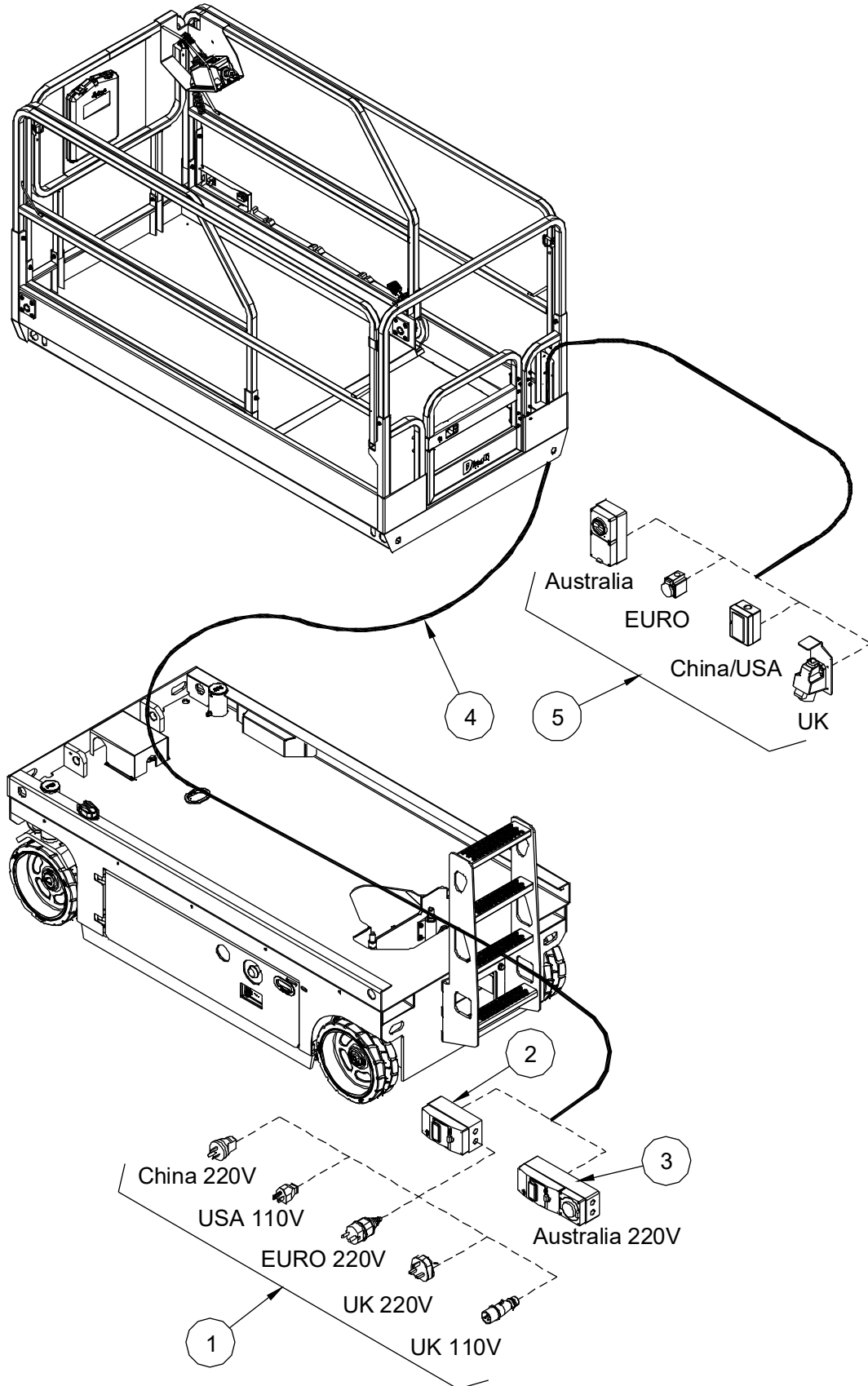

**503.1 Power to Platform**

Item	Part No.	Description	Qty.
1	00003148	AC plug (China 220V)	1
	00003149	AC plug (USA 110V)	1
	00003151	AC plug (European 220V)	1
	00003150	AC plug (UK 220V)	1
	00002615	AC plug (UK 110V)	1
2	00002634	Circuit breaker (Option)	1
3	00003147	AC plug (Australia 220V)	1
4	00003152	Wire cable, platform AC power (JCPT0808HA/AC)	1
	00007759	Wire cable, platform AC power (JCPT0812HA/AC)	1
	00003153	Wire cable, platform AC power (JCPT1008HA/AC)	1
	00003154	Wire cable, platform AC power (JCPT1012HA/AC)	1
	00003155	Wire cable, platform AC power (JCPT1212HA/AC)	1
	00003156	Wire cable, platform AC power (JCPT1412HA/AC)	1
	00003157	Wire cable, platform AC power (JCPT1612HA/AC, JCPT1614HA/AC)	1
	00005735	Wire cable, platform AC power (JCPT1612HAS/ACS)	1
5	00002617	AC socket (Australia)	1
	00002709	AC socket (European)	1
	00000668	AC socket (China/USA)	1
	00004771	AC socket (UK) (AC socket bracket: 10016048)	1

# Section 6 Decal

601.1 Decals with Words (CE)

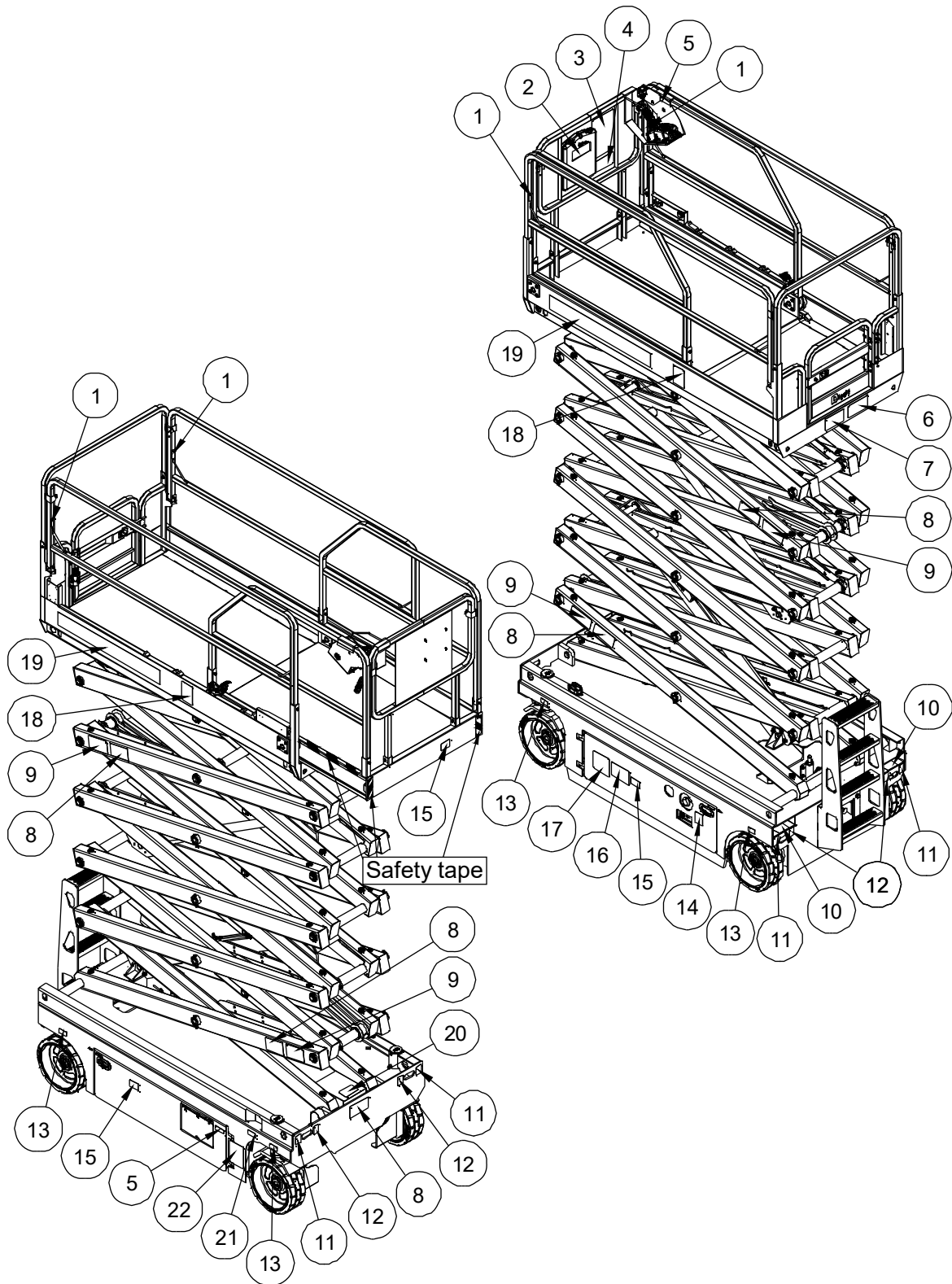

**601.1 Decals with Words (CE)**

Item	Part No.	Description	Qty.
1	09440011	Decal, Label-Lanyard anchorage point	4
2	09340001	Decal, Notice-Keep the manual with the machine	1
3	09440001	Decal, Danger-General safety rules	1
4	09440003	Decal, Danger-Tip-over hazard, tilt-alarm	1
5	09340003	Decal, Instructions-Refer the operator to the instructions for use	2
6	09440013	Decal, Label-Capacity 380kg (JCPT0808HA/AC)	1
	09440300	Decal, Label-Capacity 540kg (JCPT0812HA/AC)	1
	09440014	Decal, Label-Capacity 230kg (JCPT1008HA/AC)	1
	09440015	Decal, Label-Capacity 450kg (JCPT1012HA/AC)	1
	09440016	Decal, Label-Capacity 320kg (JCPT1212HA/AC)	1
	09440017	Decal, Label-Capacity 320kg (JCPT1412HA/AC)	1
	09440038	Decal, Label-Capacity 250kg (JCPT1612HA/AC, JCPT1612HAS/ACS)	1
7	09440005	Decal, Warning-Use indoors only (JCPT1008HA/AC, JCPT1412HA/AC, JCPT1612HA/AC, JCPT1612HAS/ACS)	1
8	09430003	Decal, Danger-Keep away from moving parts (JCPT0808HA/AC, JCPT0812HA/AC, JCPT1008HA/AC, JCPT1012HA/AC, JCPT1212HA/AC)	3
	09430003	Decal, Danger-Keep away from moving parts (JCPT1412HA/AC, JCPT1612HA/AC, JCPT1612HAS/ACS)	5
9	09430001	Decal, Danger-Safety arm (JCPT0808HA/AC, JCPT0812HA/AC, JCPT1008HA/AC, JCPT1012HA/AC, JCPT1212HA/AC)	2
	09430001	Decal, Danger-Safety arm (JCPT1412HA/AC, JCPT1612HA/AC, JCPT1612HAS/ACS)	4
10	09310001	Decal, Instructions-Forklift pockets	2
11	09310003	Decal, Instructions-Tie down point	4
12	09310002	Decal, Instructions-Lift point	4
13	09310008	Decal, Instructions-Maximum wheel load 1000kg (JCPT0808HA/AC, JCPT0812HA/AC,)	4
	09310010	Decal, Instructions-Maximum wheel load 960kg (JCPT1008HA/AC)	4
	09310012	Decal, Instructions-Maximum wheel load 1240kg (JCPT1012HA/AC)	4

**601.1 Decals with Words (CE)**

Item	Part No.	Description	Qty.
13	09310014	Decal, Instructions-Maximum wheel load 1310kg (JCPT1212HA/AC)	4
	09310016	Decal, Instructions-Maximum wheel load 1280kg (JCPT1412HA/AC)	4
	09310018	Decal, Instructions-Maximum wheel load 1350kg (JCPT1612HA/AC, JCPT1612HAS/ACS)	4
14	09310006	Decal, Notice-Main power switch operation	1
15	09540001	Decal, Label-CE	3
16	09410129	Decal, Warning-Charge warning	1
17	09410001	Decal, Danger-Explosion/burn hazard	1
18	09440009	Decal, Caution-Max. manual force 400N (Indoor)200N (Outdoor) (JCPT0808HA/AC, JCPT1212HA/AC)	2
	09440007	Decal, Caution-Max. manual force 400N (JCPT0812HA/AC, JCPT1008HA/AC, JCPT1012HA/AC, JCPT1412HA/AC, JCPT1612HA/AC, JCPT1612HAS/ACS)	2
19	09640124	Decal, Cosmetic-JCPT0808HA (JCPT0808HA)	2
	09640125	Decal, Cosmetic-JCPT0808AC (JCPT0808AC)	2
	09640121	Decal, Cosmetic-JCPT0812HA (JCPT0812HA)	2
	09640120	Decal, Cosmetic-JCPT0812AC (JCPT0812AC)	2
	09640126	Decal, Cosmetic-JCPT1008HA (JCPT1008HA)	2
	09640127	Decal, Cosmetic-JCPT1008AC (JCPT1008AC)	2
	09640128	Decal, Cosmetic-JCPT1012HA (JCPT1012HA)	2
	09640129	Decal, Cosmetic-JCPT1012AC (JCPT1012AC)	2
	09640130	Decal, Cosmetic-JCPT1212HA (JCPT1212HA)	2
	09640131	Decal, Cosmetic-JCPT1212AC (JCPT1212AC)	2
	09640132	Decal, Cosmetic-JCPT1412HA (JCPT1412HA)	2
	09640133	Decal, Cosmetic-JCPT1412AC (JCPT1412AC)	2
	09640134	Decal, Cosmetic-JCPT1612HA (JCPT1612HA)	2
	09640135	Decal, Cosmetic-JCPT1612AC (JCPT1612AC)	2
	09640119	Decal, Cosmetic-JCPT1612HAS (JCPT1612HAS)	2
	09640118	Decal, Cosmetic-JCPT1612ACS (JCPT1612ACS)	2
20	09410005	Decal, Danger-Do not alter or disable limit switch	1

**601.1 Decals with Words (CE)**

<b>Item</b>	<b>Part No.</b>	<b>Description</b>	<b>Qty.</b>
21	09310004	Decal, Instructions-Emergency lower	1
22	09410003	Decal, Warning-Inspected and operation properly	1

601.1 Decals with Words (CE)

① 09440011

② 09340001

NOTICE

KEEP THE OPERATION AND SAFETY MANUAL WITH THE MACHINE

③ 09440001

DANGER

Failure to read, understand and obey the operator's manual and the following safety rules will result in death or serious injury.

**Improper Use Hazard**

- Never use the machine as a crane.
- Always perform a pre-operation inspection.
- Always use the function keys per name.
- Read the manual.
- Only use the machine as it was intended.

Do not operate unless you are properly trained to safely operate this machine or personal, unapproved workday.

- Manufacturers instructions and safety rules.
- Operator's manual and guard.
- Operator's safety rules.
- Applicable government regulations.

**Electrocution Hazard**

This machine is not electrically insulated and will not provide protection from contact with or proximity to electrical current.

Maximum safe approach (minimum clearance)	Voltage (kV)	Distance (m)
0.30 m	0.15	0.30
0.45 m	0.25	0.45
0.60 m	0.35	0.60
0.75 m	0.50	0.75
0.90 m	0.75	0.90
1.05 m	1.00	1.05

**Tip-over Hazard**

- Do not exceed rated load capacity.
- Do not use platform unless machine is on a firm surface.
- A platform with holes and unstable or slippery surfaces.
- Do not raise platform unless machine is on a level surface.
- Do not drive machine on a slope that exceeds the maximum slope or angle rating for the machine.
- Do not drive the machine on or near uneven terrain, unstable surfaces or other hazardous conditions with the platform raised.
- Do not push off or pull toward any object out side of the platform.
- Do not place or attach protruding loads to any part of the machine.
- Use extreme care and slow speeds when driving the machine in lower position.
- Always use proper tie-off, daisy chain, snap hook or rigging methods and use holes and drag-offs.

**Crushing Hazard**

- Always use handrails and safety rules.
- Do not use platform when wind speeds may exceed 12.5 m/s.
- Do not use platform when wind speeds may exceed 12.5 m/s.
- Do not increase surface area of platform or load increasing area exposed to wind will decrease machine stability.

**Fall Protection**

Manufacturer recommends that all persons in the platform wear a full body harness with a lanyard attached to an authorized lanyard attachment point while operating this machine.

ALL PEPE must comply with applicable government regulations and must be installed and used in accordance with the manufacturer's instructions.

**Fall Hazard**

- When in operation, ensure all gates and caps are fastened and locked in their proper position.
- Do not sit, stand or climb on the platform guard rails.
- Always use a full footing on the platform floor at all times.
- Do not lean back over the platform when raised.

**Crushing Hazard**

- Always use handrails and safety rules.
- Do not use platform when driving or climbing.
- Do not use platform when driving or climbing.
- Do not use platform when driving or climbing.
- Do not use platform when driving or climbing.

**Collision Hazard**

- Be aware of blind spot distance and blind spots when driving or climbing.
- Do not use platform when driving or climbing.
- Do not use platform when driving or climbing.
- Do not use platform when driving or climbing.

**Damaged Machine Hazard**

- Do not use a damaged or malfunctioning machine.
- Do not use a damaged or malfunctioning machine.
- Do not use a damaged or malfunctioning machine.
- Do not use a damaged or malfunctioning machine.

④ 09440003

DANGER

**Tip-over Hazard**

If tilt alarm sounds, stop on a severe slope. Death or serious injury could occur.

1. Lower the platform.

2. Move the machine to level surface.

⑤ 09340003

Refer the operator to the instructions for use.

⑥ 09440013

0m/s

400N

12.5m/s

200N

⑥ 09440015

0m/s

400N

12.5m/s

200N

⑥ 09440014

0m/s

400N

12.5m/s

200N

⑥ 09440016

0m/s

400N

12.5m/s

200N

⑥ 09440017

0m/s

400N

12.5m/s

200N

⑥ 09440300

0m/s

400N

12.5m/s

400N

⑥ 09440038

0m/s

400N

12.5m/s

400N

⑦ 09440005

WARNING

**Tip-over Hazard**

This machine is intended for USE INDOORS ONLY, and must not be used outdoors as wind forces may make it unstable. MAX. allowed wind speed: 8 m/s.

⑧ 09430003

DANGER

**Crushing Hazard**

Contact with moving parts will result in death or serious injury.

- Do not stand under or around platform during operation.
- Keep away from moving parts.
- Failure to follow these instructions could result in death or serious injury.

⑨ 09430001















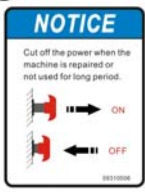

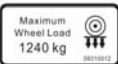

DANGER

**Crushing Hazard**

Death or serious injury can result from contact with moving scissor arms.

- Don't engage safety arm unless scissor platform.
- Engage all safety arms before performing maintenance or repair.

601.1 Decals with Words (CE)

<p>⑩ 09310001</p> 	<p>⑪ 09310003</p> 	<p>⑬ 09310008</p> 	<p>⑬ 09310014</p> 	<p>⑭ 09310006</p> 
	<p>⑫ 09310002</p> 	<p>⑬ 09310010</p> 	<p>⑬ 09310016</p> 	
		<p>⑬ 09310012</p> 	<p>⑬ 09310018</p> 	<p>⑮ 09540001</p> 
<p>⑲ 09640124</p> <p><b>JCPT0808HA</b></p>	<p>⑲ 09640125</p> <p><b>JCPT0808AC</b></p>	<p>⑯ 09410129</p> 	<p>⑱ 09440007</p> 	
<p>⑲ 09640121</p> <p><b>JCPT0812HA</b></p>	<p>⑲ 09640120</p> <p><b>JCPT0812AC</b></p>	<p>⑰ 09410001</p> 	<p>⑱ 09440009</p> 	
<p>⑲ 09640126</p> <p><b>JCPT1008HA</b></p>	<p>⑲ 09640127</p> <p><b>JCPT1008AC</b></p>	<p>⑳ 09410003</p> 	<p>㉑ 09410005</p> 	
<p>⑲ 09640128</p> <p><b>JCPT1012HA</b></p>	<p>⑲ 09640129</p> <p><b>JCPT1012AC</b></p>			
<p>⑲ 09640130</p> <p><b>JCPT1212HA</b></p>	<p>⑲ 09640131</p> <p><b>JCPT1212AC</b></p>			
<p>⑲ 09640132</p> <p><b>JCPT1412HA</b></p>	<p>⑲ 09640133</p> <p><b>JCPT1412AC</b></p>			
<p>⑲ 09640134</p> <p><b>JCPT1612HA</b></p>	<p>⑲ 09640135</p> <p><b>JCPT1612AC</b></p>	<p>⑲ 09640119</p> <p><b>JCPT1612HAS</b></p>	<p>⑲ 09640118</p> <p><b>JCPT1612ACS</b></p>	<p>㉒ 09310004</p> 

### 602.1 Decals with Symbols (CE)

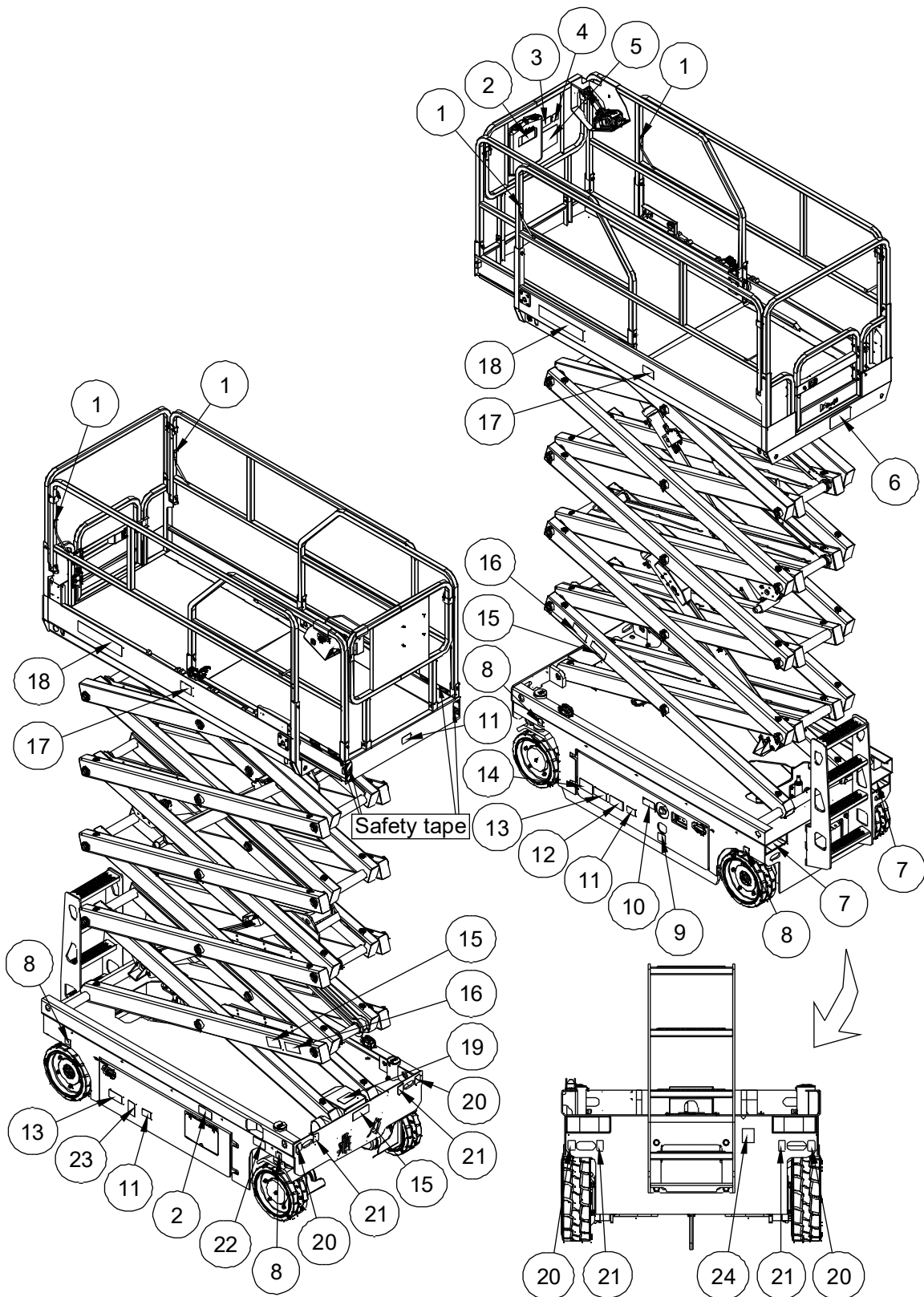

**602.1 Decals with Symbols (CE)**

Item	Part No.	Description	Qty.
1	09440089	Decal, Label-Lanyard anchorage point	4
2	09340026	Decal, Symbols-Refer the operator to the instructions for use	2
3	09440090	Decal, Symbols-Tip-over hazard, tilt-alarm	1
4	09340027	Decal, Instructions-Directional arrows	1
5	09440091	Decal, Symbols-General safety rules	1
6	09440013	Decal, Label-Capacity 380kg (JCPT0808HA/AC)	1
	09440300	Decal, Label-Capacity 540kg (JCPT0812HA/AC)	1
	09440014	Decal, Label-Capacity 230kg (JCPT1008HA/AC)	1
	09440015	Decal, Label-Capacity 450kg (JCPT1012HA/AC)	1
	09440016	Decal, Label-Capacity 320kg (JCPT1212HA/AC)	1
	09440017	Decal, Label-Capacity 320kg (JCPT1412HA/AC)	1
	09440038	Decal, Label-Capacity 250kg (JCPT1612HA/AC, JCPT1612HAS/ACS)	1
7	09310001	Decal, Instructions-Forklift pockets	2
8	09310086	Decal, Instructions-Maximum wheel load: 1000kg (JCPT0808HA/AC, JCPT0812HA/AC)	4
	09310087	Decal, Instructions-Maximum wheel load: 960kg (JCPT1008HA/AC)	4
	09310088	Decal, Instructions-Maximum wheel load: 1240kg (JCPT1012HA/AC)	4
	09310089	Decal, Instructions-Maximum wheel load: 1310kg (JCPT1212HA/AC)	4
	09310090	Decal, Instructions-Maximum wheel load: 1280kg (JCPT1412HA/AC)	4
	09310091	Decal, Instructions-Maximum wheel load: 1350kg (JCPT1612HA/AC, JCPT1612HAS/ACS)	4
9	09310099	Decal, Symbols-Battery charging instructions	1
10	09310078	Decal, Symbols-Main power switch operation	1
11	09540001	Decal, Label-CE	3
12	09410048	Decal, Symbols-Explosion/burn hazard	1
13	09410049	Decal, Symbols-Electrocution hazard	2
14	09410147	Decal, Symbols-Charge warning	1

**602.1 Decals with Symbols (CE)**

Item	Part No.	Description	Qty.
15	09430009	Decal, Symbols-Keep away from moving parts (JCPT0808HA/AC, JCPT0812HA/AC, JCPT1008HA/AC, JCPT1012HA/AC, JCPT1212HA/AC)	3
	09430009	Decal, Symbols-Keep away from moving parts (JCPT1412HA/AC, JCPT1612HA/AC, JCPT1612HAS/ACS)	5
16	09430008	Decal, Symbols-Safety arm (JCPT0808HA/AC, JCPT0812HA/AC, JCPT1008HA/AC, JCPT1012HA/AC, JCPT1212HA/AC)	2
	09430008	Decal, Symbols-Safety arm (JCPT1412HA/AC, JCPT1612HA/AC, JCPT1612HAS/ACS)	4
17	09440085	Decal, Symbols-Max. manual force 400N (Indoor) 200N (Outdoor) (JCPT0808HA/AC, JCPT1212HA/AC)	2
	09440086	Decal, Symbols-Max. manual force 400N (Indoor) (JCPT1008HA/AC, JCPT1612HA/AC, JCPT1612HAS/ACS)	2
	09440087	Decal, Symbols-Max. manual force 400N (Indoor) 400N (Outdoor) (JCPT0812HA/AC, JCPT1012HA/AC)	2
	09440088	Decal, Symbols-Max. manual force 400N (Indoor) (JCPT1412HA/AC)	2
18	09640124	Decal, Cosmetic-JCPT0808HA (JCPT0808HA)	2
	09640125	Decal, Cosmetic-JCPT0808AC (JCPT0808AC)	2
	09640121	Decal, Cosmetic-JCPT0812HA (JCPT0812HA)	2
	09640120	Decal, Cosmetic-JCPT0812AC (JCPT0812AC)	2
	09640126	Decal, Cosmetic-JCPT1008HA (JCPT1008HA)	2
	09640127	Decal, Cosmetic-JCPT1008AC (JCPT1008AC)	2
	09640128	Decal, Cosmetic-JCPT1012HA (JCPT1012HA)	2
	09640129	Decal, Cosmetic-JCPT1012AC (JCPT1012AC)	2
	09640130	Decal, Cosmetic-JCPT1212HA (JCPT1212HA)	2
	09640131	Decal, Cosmetic-JCPT1212AC (JCPT1212AC)	2
	09640132	Decal, Cosmetic-JCPT1412HA (JCPT1412HA)	2
	09640133	Decal, Cosmetic-JCPT1412AC (JCPT1412AC)	2
	09640134	Decal, Cosmetic-JCPT1612HA (JCPT1612HA)	2
	09640135	Decal, Cosmetic-JCPT1612AC (JCPT1612AC)	2
	09640119	Decal, Cosmetic-JCPT1612HAS (JCPT1612HAS)	2
09640118	Decal, Cosmetic-JCPT1612ACS (JCPT1612ACS)	2	

**602.1 Decals with Symbols (CE)**

<b>Item</b>	<b>Part No.</b>	<b>Description</b>	<b>Qty.</b>
19	09410051	Decal, Symbols-Do not alter or disable limit switch	1
20	09310003	Decal, Instructions-Tie down point	4
21	09310002	Decal, Instructions-Lift point	4
22	09310096	Decal, Symbols-Emergency lower	1
23	09410050	Decal, Symbols-Injection hazard	1
24	09310098	Decal, Symbols-Platform power instructions	1

602.1 Decals with Symbols (CE)

<p>① 09440089</p>	<p>② 09340026</p>	<p>③ 09440090</p>	<p>⑤ 09440091</p>
<p>⑥ 09440013</p>	<p>④ 09340027</p>	<p>⑦ 09310001</p>	
<p>⑥ 09440015</p>	<p>⑧ 09310086</p>	<p>⑧ 09310087</p>	
<p>⑥ 09440016</p>	<p>⑧ 09310088</p>	<p>⑧ 09310089</p>	
<p>⑥ 09440300</p>	<p>⑧ 09310090</p>	<p>⑧ 09310091</p>	
<p>⑥ 09440014</p>	<p>⑨ 09310099</p>	<p>⑩ 09310078</p>	<p>⑪ 09540001</p>
<p>⑥ 09440017</p>	<p>⑥ 09440038</p>	<p>⑫ 09410048</p>	

602.1 Decals with Symbols (CE)

<p>⑬ 09410049</p>	<p>⑮ 09430009</p>	<p>⑰ 09440085</p>	<p>⑰ 09440086</p>
<p>⑭ 09410147</p>	<p>⑯ 09430008</p>	<p>⑰ 09440087</p>	<p>⑰ 09440088</p>
<p>⑱ 09640124</p> <p><b>JCPT0808HA</b></p>	<p>⑲ 09410051</p>	<p>⑳ 09310003</p>	
<p>⑱ 09640125</p> <p><b>JCPT0808AC</b></p>	<p>㉒ 09310096</p>	<p>㉑ 09310002</p>	
<p>⑱ 09640121</p> <p><b>JCPT0812HA</b></p>	<p>㉓ 09410050</p>	<p>㉔ 09310098</p>	
<p>⑱ 09640120</p> <p><b>JCPT0812AC</b></p>			
<p>⑱ 09640126</p> <p><b>JCPT1008HA</b></p>			
<p>⑱ 09640127</p> <p><b>JCPT1008AC</b></p>			
<p>⑱ 09640128</p> <p><b>JCPT1012HA</b></p>			
<p>⑱ 09640129</p> <p><b>JCPT1012AC</b></p>			
<p>⑱ 09640130</p> <p><b>JCPT1212HA</b></p>	<p>⑱ 09640134</p> <p><b>JCPT1612HA</b></p>		
<p>⑱ 09640131</p> <p><b>JCPT1212AC</b></p>	<p>⑱ 09640135</p> <p><b>JCPT1612AC</b></p>		
<p>⑱ 09640132</p> <p><b>JCPT1412HA</b></p>	<p>⑱ 09640119</p> <p><b>JCPT1612HAS</b></p>		
<p>⑱ 09640133</p> <p><b>JCPT1412AC</b></p>	<p>⑱ 09640118</p> <p><b>JCPT1612ACS</b></p>		