

Haulotte

Compact 10 EN 280

2420327810 - e 10.05 Ind. A



F

Pièces de rechange



GB

Spare parts



D

Ersatzteile



NL

Onderdelen



DK

Reservedele



E

Piezas de repuesto



I

Pezzi di ricambio



P

Peças sobressalentes



S

Reservdel



SF

Varaosä



Haulotte Groupe - La Péronnière - BP 9 - 42152 l'Horme - France • Tél : +33 (0)4 77 29 24 24 - Fax : +33 (0)4 77 29 43 95

Haulotte 
GROUP

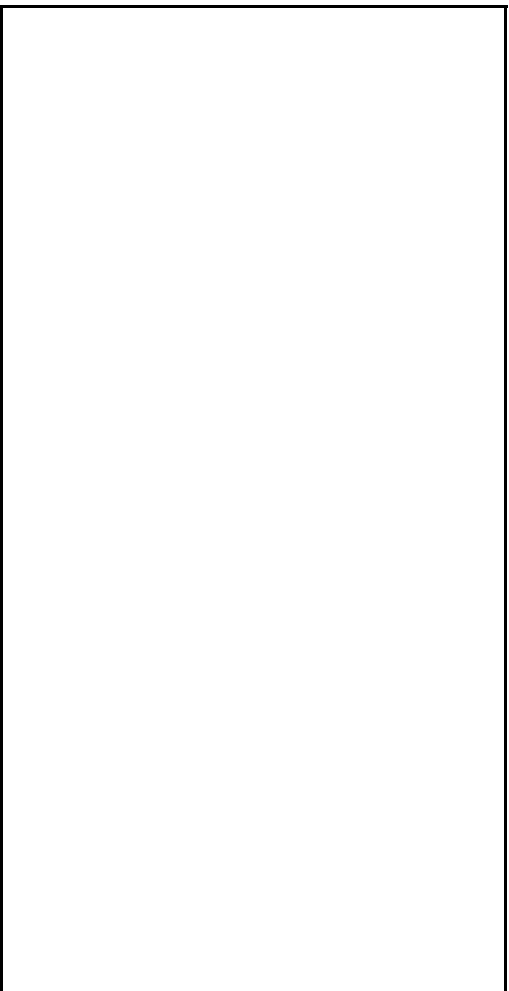

Haulotte France
Tél / Phone +33 (0)4 72 88 05 70
Fax / Fax +33 (0)4 72 88 01 43



**Centre Mondial Pièces de Rechange
Spare Parts International Centre**
Tél / Phone +33 (0)4 77 29 24 51
Fax / Fax +33 (0)4 77 29 98 88



Haulotte Hubarbeitsbühnen
Tél / Phone +49 76 33 806 920
Fax / Fax +49 76 33 806 82 18



Haulotte Portugal
Tél / Phone +351 21 955 98 10
Fax / Fax +351 21 995 98 19



Haulotte UK
Tél / Phone +44 (0) 1952 292753
Fax / Fax² +44 (0) 1952 292758



Haulotte U.S. Inc.
Main tool free 1-877-HAULOTTE
Service tool free 1-877-HAULOT-S



Haulotte Asia
Tél / Phone +65 6536 3989
Fax / Fax +65 6536 3969



Haulotte Netherlands BV
Tél / Phone +31 162 670 707
Fax / Fax +31 162 670 710



Haulotte Australia PTY Ltd
Tél / Phone +61 3 9706 6787
Fax / Fax +61 3 9706 6797



Haulotte Italia
Tél / Phone +39 05 17 80 813
Fax / Fax +39 05 16 05 33 28



Haulotte Do Brazil
Tél / Phone +55 11 3026 9177
Fax / Fax +55 3026 9178



Haulotte Scandinavia AB u.b.
Tél / Phone +46 31 744 32 90
Fax / Fax +46 31 744 32 99



Haulotte Iberica - Madrid
Tél / Phone +34 91 656 97 77
Fax / Fax +34 91 656 97 81



Haulotte Portugal
Tél / Phone +351 21 955 98 10
Fax / Fax +351 21 995 98 19



Haulotte Iberica - Sevilla
Tél / Phone +34 95 493 44 75
Fax / Fax +34 95 463 69 44

Pourquoi n'utiliser que des pièces de rechange d'origine Haulotte ?

1. REMISE EN CAUSE DE LA DECLARATION DE CONFORMITE CE

Les remplacements ou modifications de composants autres que ceux recommandés par **Pinguely-Haulotte**, peuvent remettre en cause les conditions initiales de la sécurité de notre matériel **Haulotte**.

Toute opération de ce type sur notre matériel **Haulotte** sera à la charge entière de celui qui sera intervenu et mettra en cause la validité du marquage CE délivré par **Pinguely-Haulotte**. La déclaration CE de conformité devient caduque et **Pinguely-Haulotte** dégage sa responsabilité réglementaire.

2. ARRET DE LA GARANTIE

La garantie contractuelle offerte par **Pinguely-Haulotte** sur ses équipements **Haulotte** n'est plus opposable à **Pinguely-Haulotte** dès que vous utilisez des pièces de rechange autres que les pièces d'origine.

3. RESPONSABILITE CIVILE ET PENALE

La contrefaçon et la concurrence déloyale de pièces sont condamnées par la loi civile et pénale.

La contrefaçon engage la responsabilité civile et pénale du fabricant, du revendeur, voir dans certains cas de l'utilisateur des pièces de contrefaçon.

La concurrence déloyale engage la responsabilité civile du fabricant du revendeur d'une « copie servile » qui tirant de cette opération un avantage injustifié, fausse, les règles normales de la concurrence et réalise un acte de « parasitisme » en détournant les efforts de conception, de mise au point, de recherche de la meilleure adéquation, et le savoir faire de **Pinguely-Haulotte**.

POURQUOI PRENDRE DES RISQUES INUTILES ?

POUR VOTRE SECURITE , EXIGEZ DES PIECES D'ORIGINE HAULOTTE



4. QUALITE

L'utilisation de pièces d'origines **Pinguely-Haulotte** c'est l'assurance :

- D'un contrôle qualité performant
- Des dernières évolutions technologiques
- D'une parfaite sécurité
- De meilleures performances
- D'une meilleure durée de vie de votre équipement **Haulotte**
- De la garantie **Pinguely-Haulotte**
- Du support technique de nos techniciens et agents réparateurs

5. DISPONIBILITE

Utiliser des pièces d'origine **Pinguely-Haulotte**, c'est profiter de la disponibilité de 40 000 références en stock permanent et d'un taux de service de 98%.

POURQUOI NE PAS EN PROFITER ?

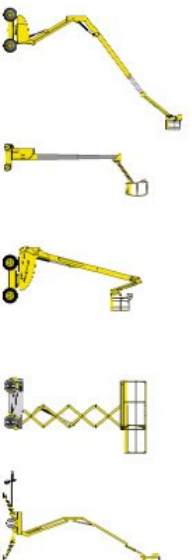

Why use only Haulotte original spare-parts ?

1. RECALLING THE EEC DECLARATION OF CONFORMITY IN QUESTION

Components, substitutions, or modifications other than the ones recommended by **Pinguely-Haulotte** may recall in question the initial security conditions of our **Haulotte** equipment. The person who would have intervened for any operation of this kind will take responsibility and recall in question the EEC marking validity granted by **Pinguely-Haulotte**. The EEC declaration will become null and void and **Pinguely-Haulotte** will disclaim regulation responsibility.

2. END OF THE WARRANTY

The contractual warranty offered by **Pinguely-Haulotte** for its equipment will no longer be applied after spare-parts other than original ones are used.

3. PUBLIC AND PENAL LIABILITY

The manufacture and unfair competition of fake spare-parts will be sentenced by public and penal law. The usage of fake spare-parts will invoke the civil and penal liability of the manufacturer, of the retailer, and, in some cases, of the person who used the fake spare-parts.

Unfair competition invokes the civil liability of the manufacturer and the retailer of a “slavish copy” which, taking unjustified advantage of this operation, distorts the normal rules of competition and creates a “parasitism” act by diverting efforts of design, perfection, research of best suitability, and the know-how of **Pinguely-Haulotte**.

FOR YOUR SECURITY, REQUIRE HAULOTTE ORIGINAL SPARE-PARTS



4. QUALITY

Using **Pinguely-Haulotte** original spare-parts means guarantee of :

- Efficient quality control
- The last technological evolution
- Perfect security
- Best performance
- The best useful life of your **Haulotte** equipment
- The **Pinguely-Haulotte** warranty
- Our technicians' and repair agents' technical support

5. AVAILABILITY

Using Haulotte original spare-parts means taking advantage of 40 000 references available in our permanent stock and a 98% service rate.

WHY NOT TAKE ADVANTAGE ?



C

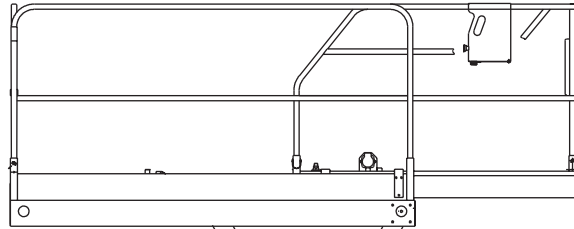

B

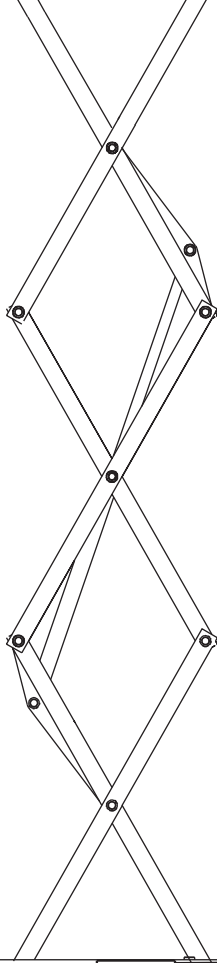

A

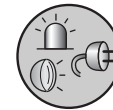
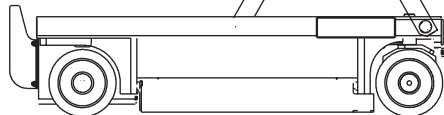

D

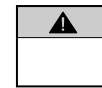

E



F

D16082 b

**▲ Groupes Machine
Machine groups**

Compact 10 - Compact 2747E

Rep.	Désignation	Designation
A	Partie basse	Bottom part
B	Ensemble ciseaux	Scissor lift platform unit
C	Plate-forme	Platform
D	Option	Option
E	Etiquettes	Labels
F	Electricité	Electricity

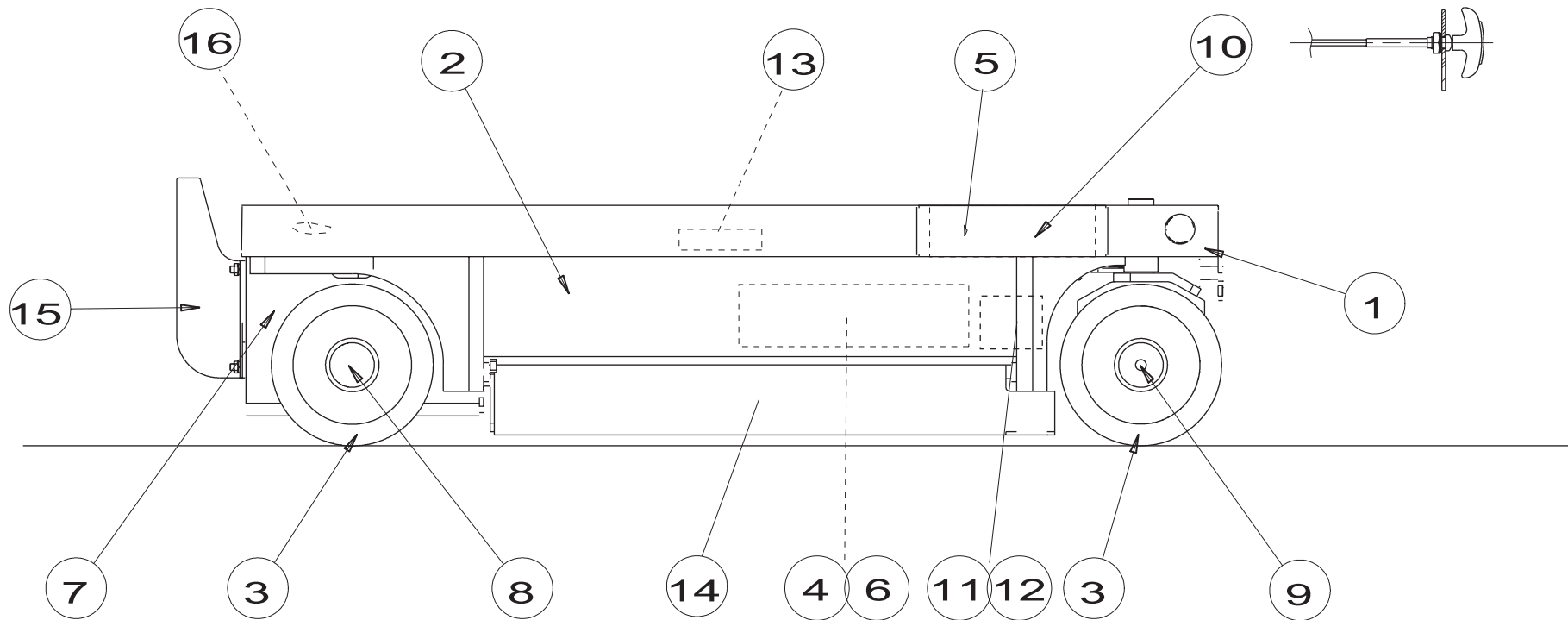

D16076a

▲ Partie basse
Bottom part



Rep.	Désignation	Designation	Specification	Up to / jusqu'à
1	Châssis	Frame		
2	Capotage châssis	Frame cowling		
3	Roues	Wheels		
4	Installation hydraulique	Hydraulic installation		
4	Schéma hydraulique	Hydraulic diagram		
5	Ensemble pupitre	Control panel unit		
5	Kit compos. élec.	Electrical component kit		
5	Ens. montage pupitre	Plate mounting unit		
6	Centrale hydraulique	Central hydraulic plant		
7	Coffre à batterie	Battery box		
8	Essieu AR	Rear axle		
9	Essieu moto-directeur	Motor guiding axle		
10	Commande de secours	Emergency control		
11	Détecteur de dévers	Tilt detector		
12	Coupure G.V.	High Speed cut-off		
13	Fin de course levage	End of travel		
14	Pothole	Anti-tipping over device		
15	Marche pied	Step		
16	Capteur d'angle	Angle sensor		

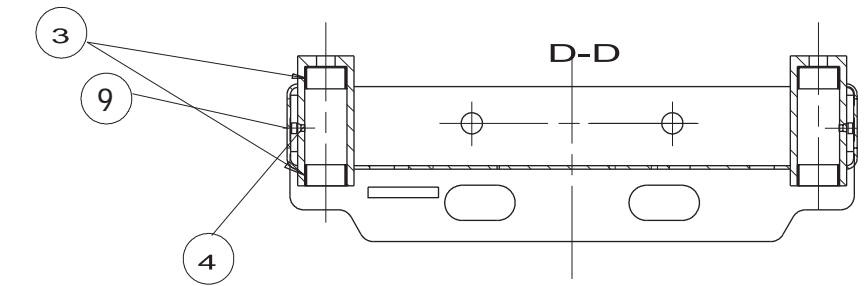
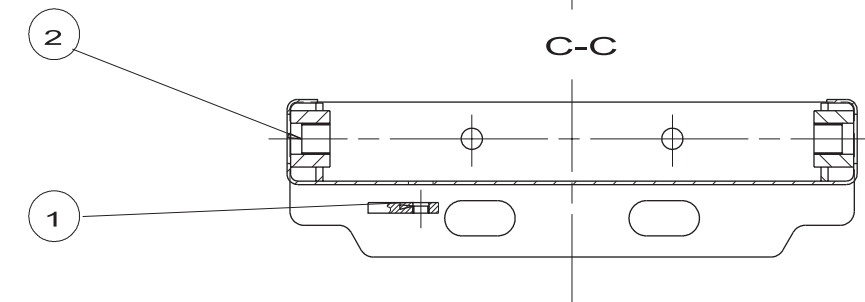
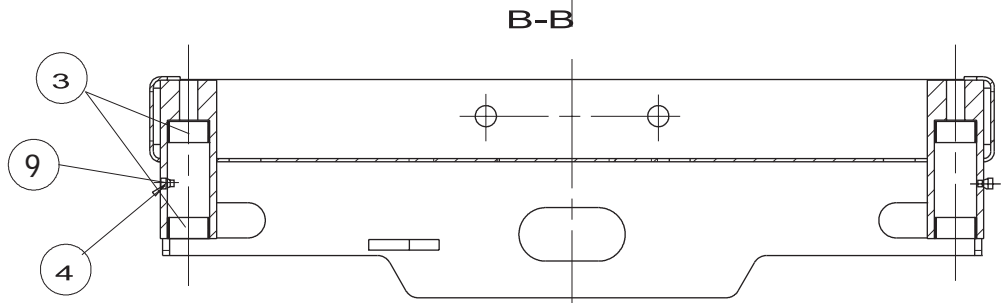
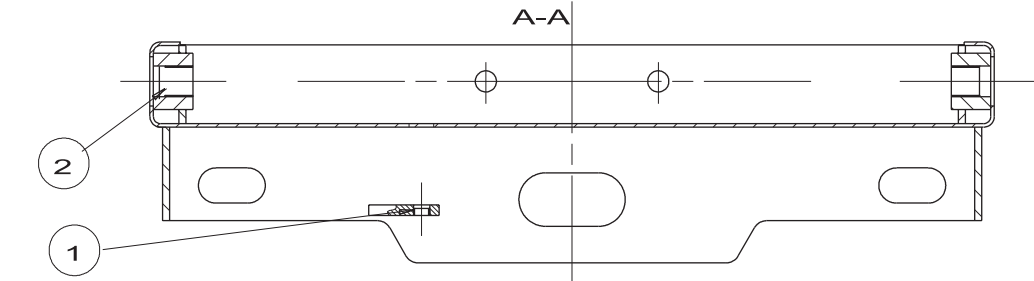
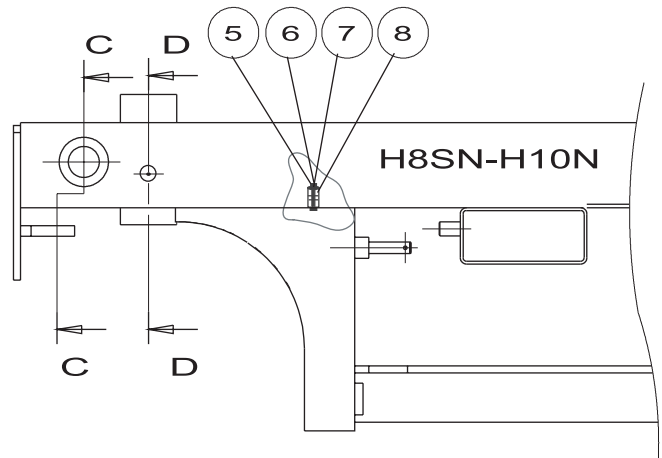
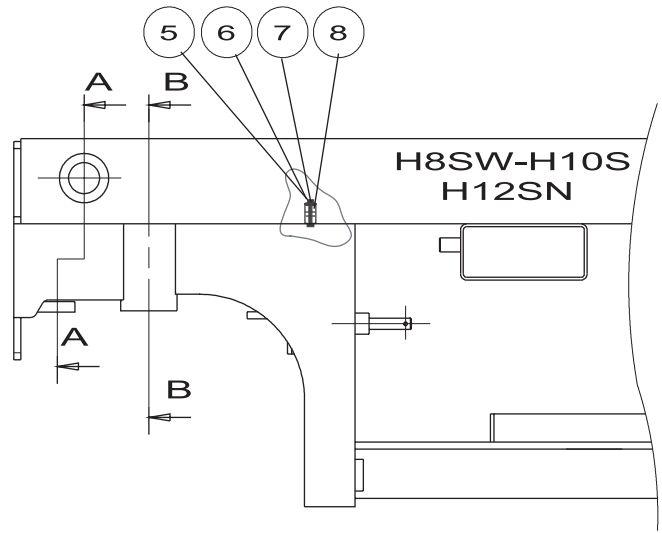

C 15171 e

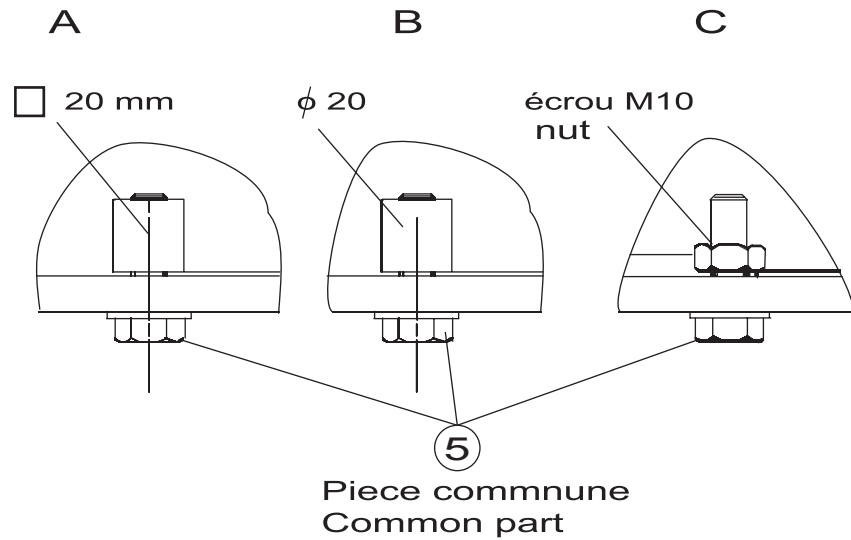
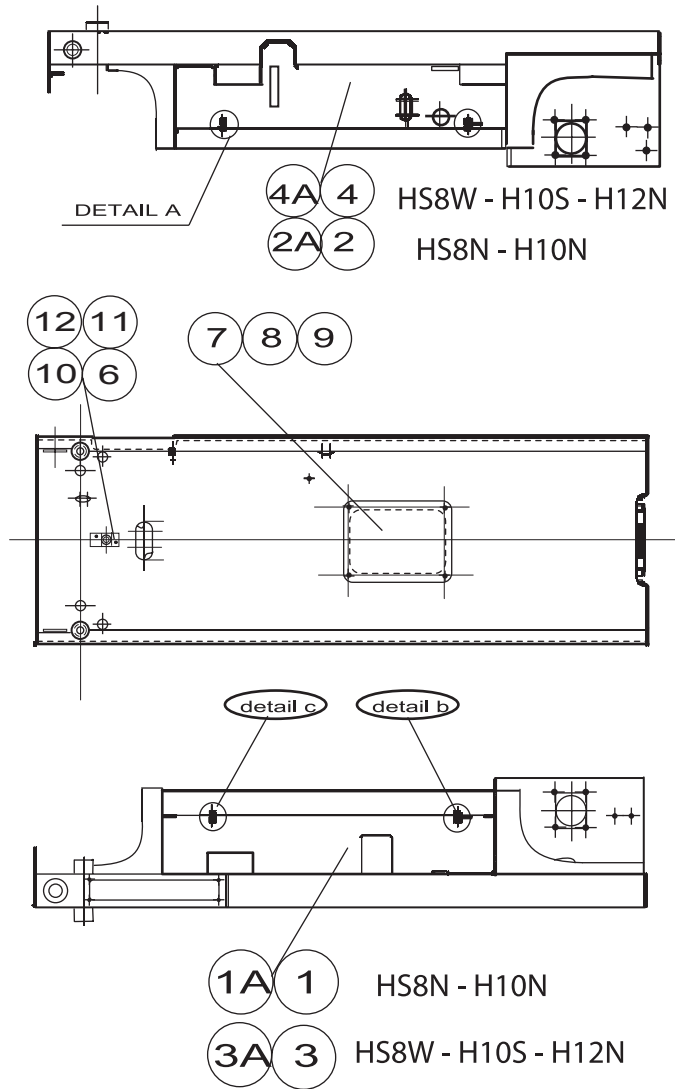

C15348e

▲ **Capotage châssis**
Frame cowling

Rep.	Désignation	Designation	Specification	Qty	Code	Up to / jusqu'à
3	Capot DR	Right hood		1	119B156960	
4	Capot GA	Left hood		1	119B156980	
6	Capot de protection	Protective cover		1	118D169420	
10	Agrafe	Fastener		2	2420105100	
11	Rivet	Rivet	TAPD Ø4 LG.10,5	2	2421809000	
12	Galon non feutré	Braid (not felt)	DRAFTEX	300	2420701180	

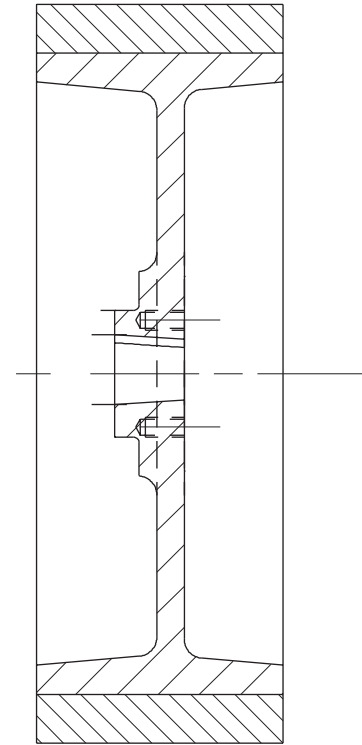
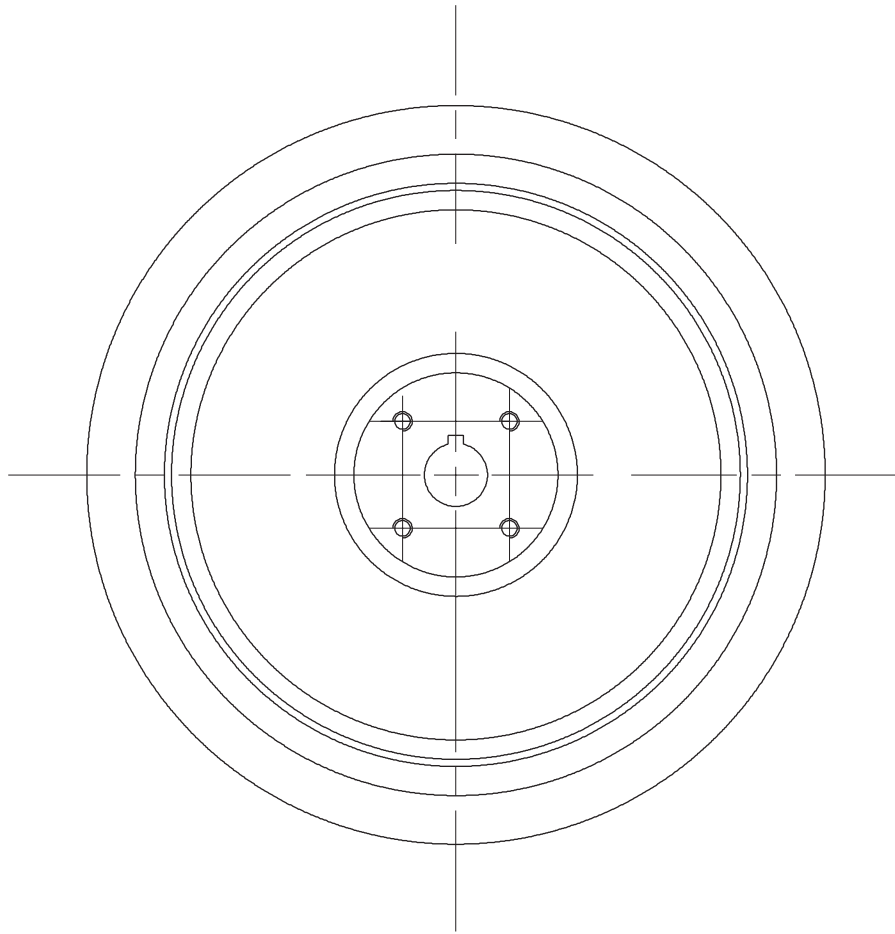

B15638f

▲ Installation hydraulique
Hydraulic installation

Rep.	Désignation	Designation	Specification	Qty	Code	Up to / jusqu'à
1	Union	Union piece	M.JIC37 (18)M 1 BSPP	1	2369110220	
2	Union	Union piece	M.JIC 37	3	2369117210	
3	Union	Union piece	M.JIC 37	2	2369117190	
4	Union mâle	Male union piece	JIC37(10)M.7/8-14 UNF	4	2369111430	
5	Union	Union piece	M JIC37	9	2369117360	
6	Union	Union piece	M.JIC 37	10	2369117120	
7	Union mâle	Male union piece	JIC37(6)M.7/16-20 UNF	2	2369111440	
8	Union égale	Union piece	TC M.JIC 37 (10)	2	2369109100	
9	Coude	Bend	JIC 37 90°	3	2369132090	
11	Coude	Bend	JIC 37 90°	1	2369135180	
13	Té égal	Equal T-piece	JIC 37	1	2369147000	
14	Prise Minimess	Minimess tap	1/4' G	1	2441604150	
15	Flexible	Flexible	S449 0,55m	1	2369071110	
17	Flexible	Flexible	SP 5241 lg 600	1	2369071690	
18	Flexible	Flexible	SP 5241 lg 540	1	2369071700	
19	Flexible	Flexible	SP.1756 3,100m	1	2369070820	
22	Flexible	Flexible	S1756 1,3m	1	2369058900	
25	Flexible	Flexible	SP. 5250 2,050m	1	2369071650	
26	Flexible	Flexible	S5239 Lg 1950	3	2369071730	
29	Flexible	Flexible	SP 5250 0,930m	1	2369071760	
31	Flexible	Flexible	S5239 0,920m	1	2369071770	
33	Flexible	Flexible	S5175 3,82m	1	2369071420	
36	Flexible	Flexible	S1707 1,51m	2	2369069640	
37	Flexible	Flexible	S5238 Lg 1370	1	2369071780	
39	Flexible	Flexible	S5238 0,530m	1	2369071800	
40	Flexible	Flexible	S5255 1,1710m	2	2369071810	

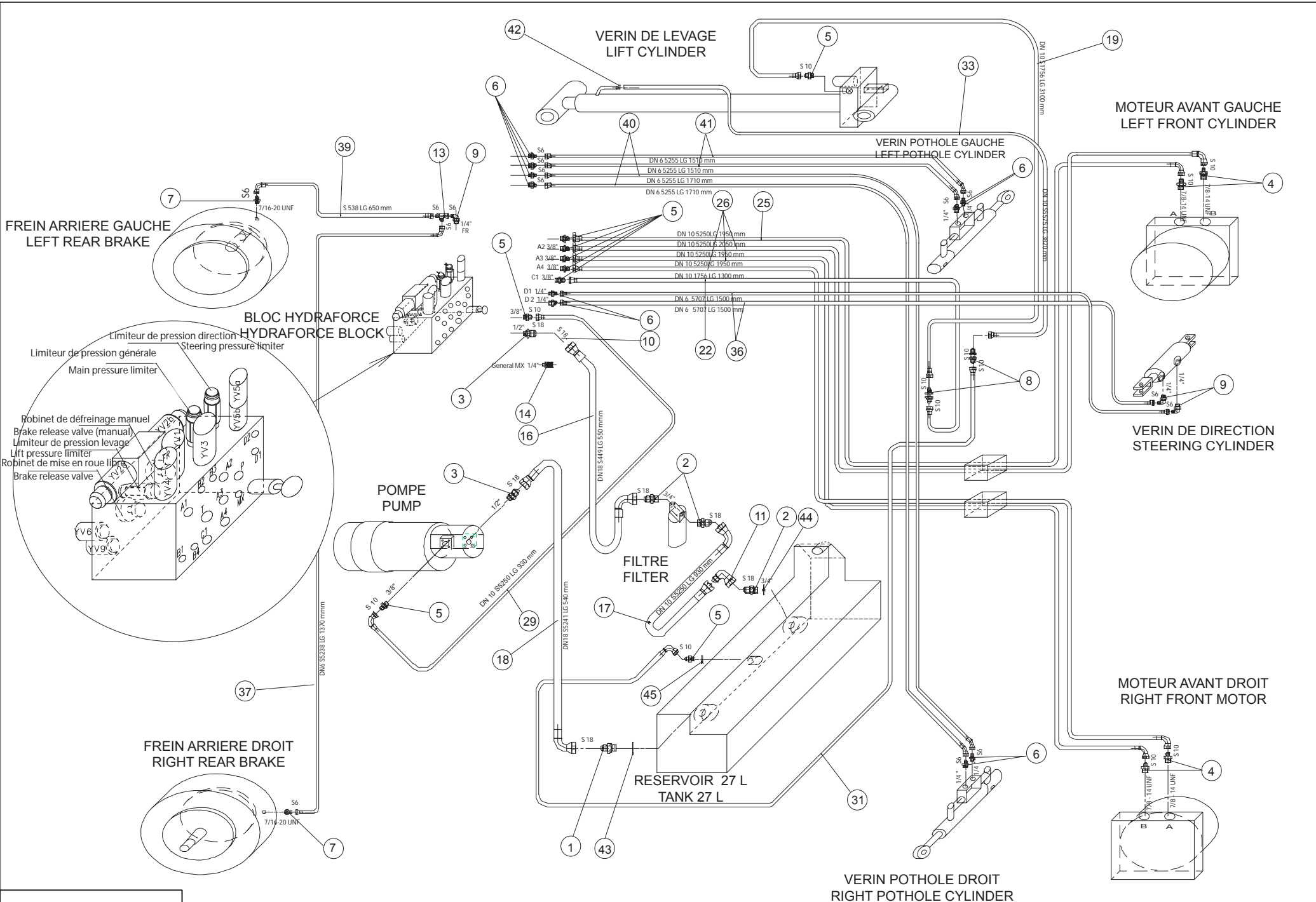

A14563b

▲ **Installation hydraulique**
Hydraulic installation

Rep.	Désignation	Designation	Specification	Qty	Code	Up to / jusqu'à
41	Flexible	Flexible	S5255 1,510m	2	2369071820	
42	Collier	Collar		1	2389002540	
43	Rondelle	Washer	Ø41,5/33 ep=2	1	118D160580	
44	Rondelle	Washer	Ø36/27 ep=2	1	118D160570	
45	Rondelle	Washer	Ø23,5/17 ep=2	1	118D160560	

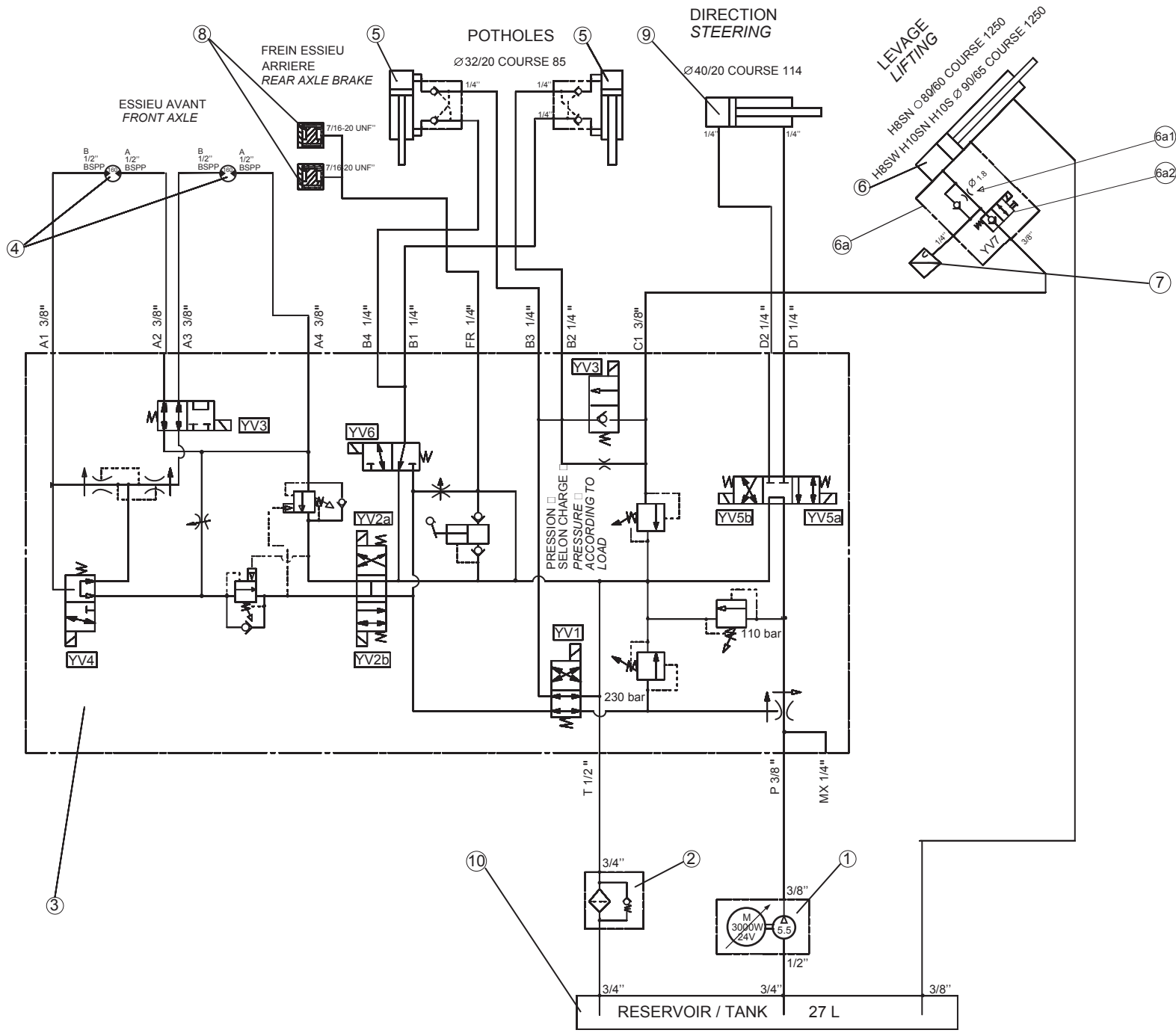

118P251510 B

RESERVOIR / TANK 27 L

▲ Schéma hydraulique Hydraulic diagram

Rep.	Désignation	Designation	Specification	Qty	Code	Up to / jusqu'à
1	Groupe motopompe	Pump motor unit	S5355	1	2420703820	
2	Filtre à huile	Oil filter	3/4 BSPP	1	2427010430	
3	Bloc de distribution	Distribution block	MK4	1	2420212090	
4	Moteur hydraulique	Hydraulic motor	300CC - SP.5122	2	2431202050	
	<i>Bloc de régulation</i>	<i>Control block</i>		1	2420210170	
	<i>Pochette de joints</i>	<i>Bag of seals</i>		1	2421693000	
5	Vérin de pothole	Pothole cylinder		2	118C174240	
6	Vérin de levage comprenant :	Lifting cylinder including:		1	120P248780	
6a	<i>Bloc flasqué comprenant :</i>	<i>Flanged block including:</i>		1	2420210980	
6a1	<i>Clapet anti-retour + Gicleur Ø 1.8</i>	<i>One-way valve + Spray nozzle Ø 1.8</i>		1		
6a2	<i>Electrovalve + cde manuelle</i>	<i>Electrovalve + manual control</i>		1		
7	Capteur de pression	Pressure sensor		1	2421620600	
8	Frein	Brake	S5123	2	2420602750	
9	Vérin de direction	Steering cylinder		1	118C149370	
10	Réservoir hydraulique	Hydraulic tank	27L	1	1180607010	

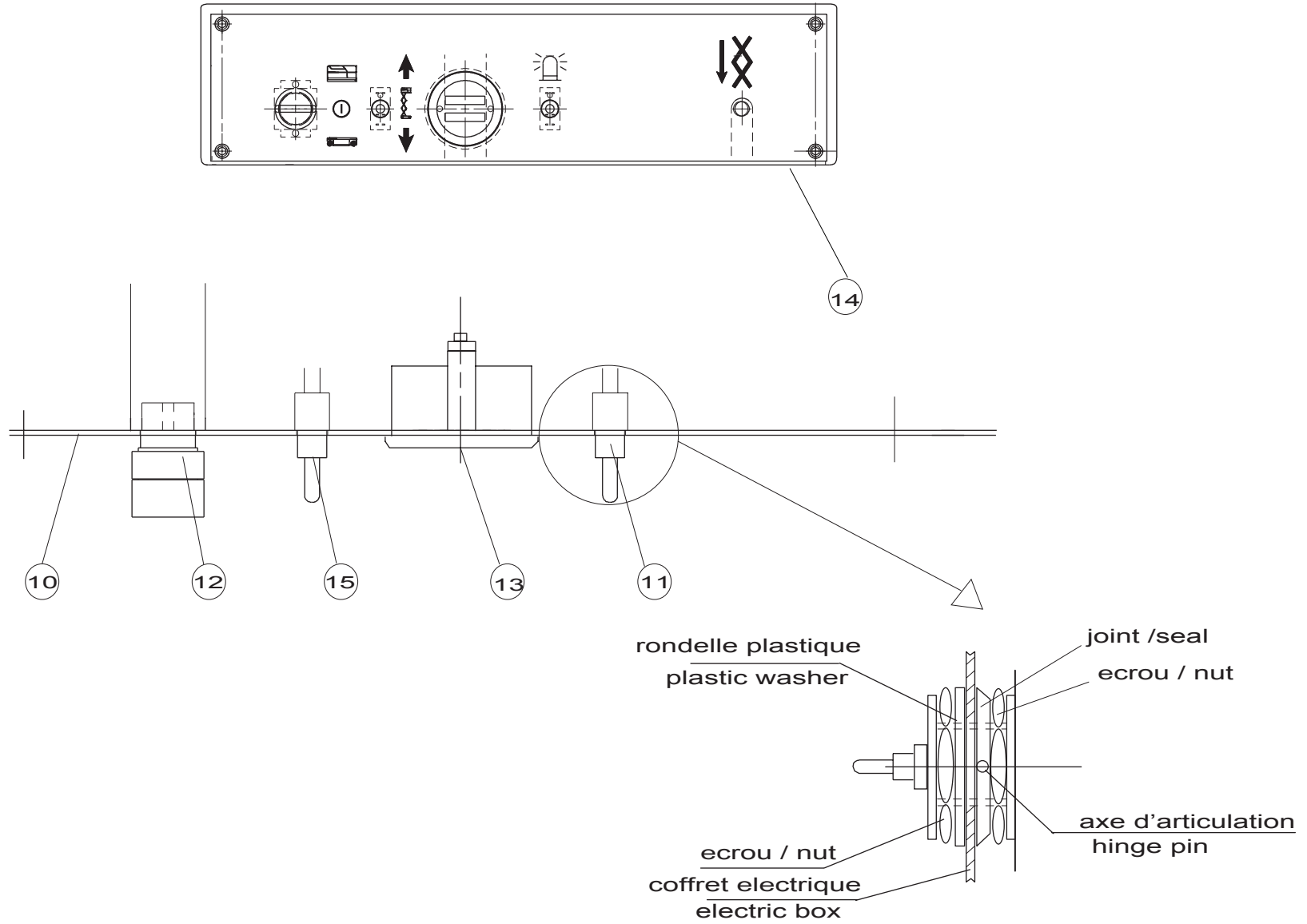

C17512

**▲ Ensemble pupitre
Control panel unit**

**◀ A5 ▶
1/4 ▶**

Rep.	Désignation	Designation	Specification	Qty	Code	Up to / jusqu'à
10	Support	Holder		1	118C150370	
11	Inter. Bipolaire levier	Double-pole toggle switch		1	2440901620	
12	Bouton tournant clef	Rotary knob with key		1	2442009630	
12	Contact auxiliaire	Auxiliary contact		2	2440318780	
12	Corps complet	Contact block		1	2440314390	
	<i>Contact auxiliaire</i>	<i>Auxiliary contact</i>		8	2440318780	
	<i>Tête de bouton tournant</i>	<i>Turn knob head</i>	<i>ZB4 BD5</i>	4	2442009580	
13	Indicateur	Indicator	24V-80V	1	2440904140	
14	Pupitre bas	« Bottom panel » label		1	3078145060	
15	Inter. unipolaire levier	Single-pole toggle switch		1	2440901650	
16	Faisceau	Bundle		1	118B157960	

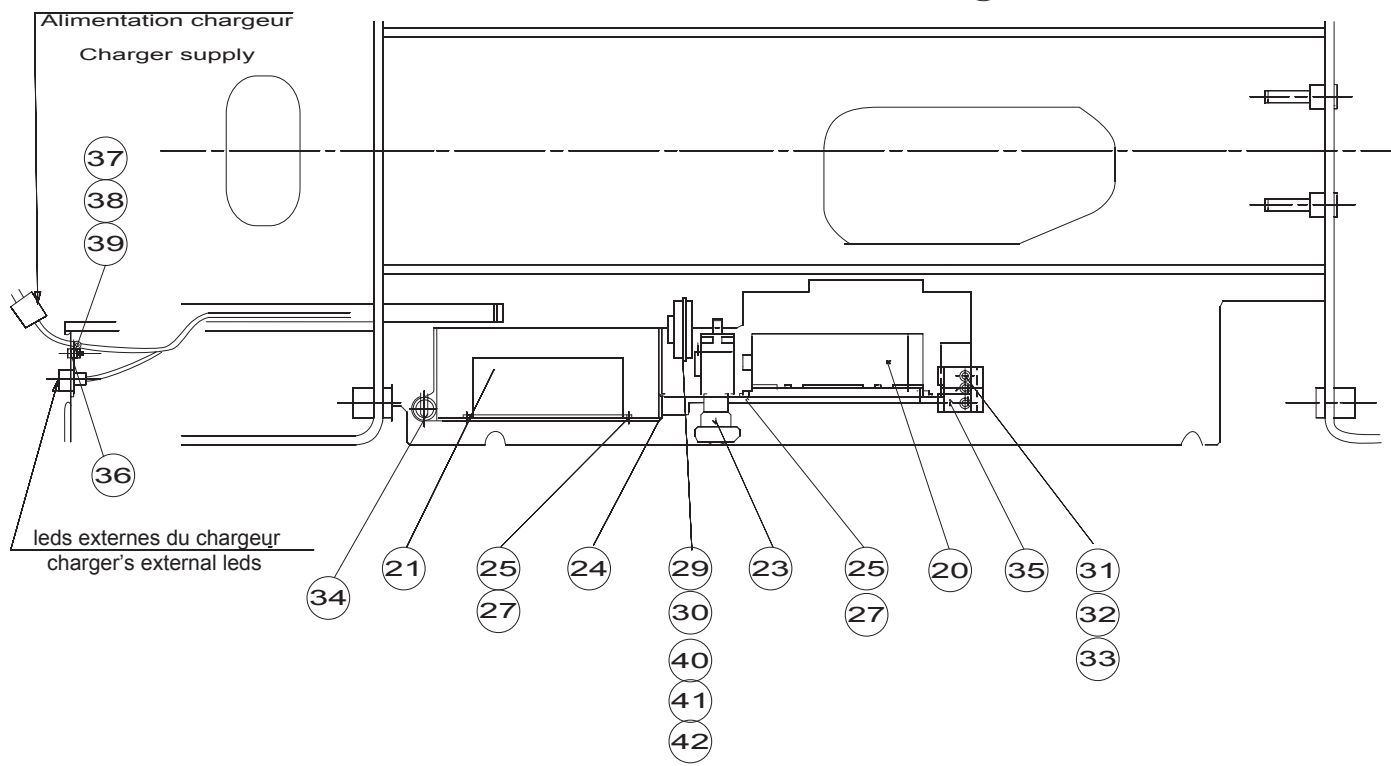
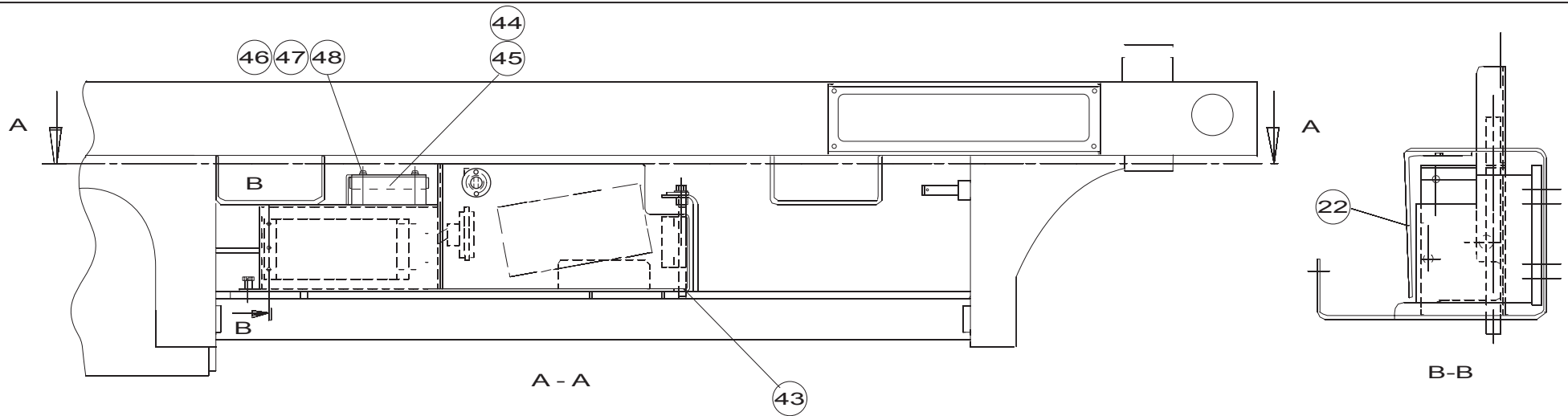

121P239410 B

**▲ Kit compos. élec.
Electrical component kit**

◀ **A5**
2/4 ▶

Rep.	Désignation	Designation	Specification	Qty	Code	Up to / jusqu'à
20	Variateur	Variable speed unit	24V400A	1	2901001630	
21	Chargeur batterie	Battery charger	S5290	1	2440316740	
22	Protect. Charg. autocol.	Adhesive charger protection		1	118D165960	
23	Coupe batterie	Battery cut-off		1	2440306180	
24	Support	Holder		1	121P239420	
25	Ecrou frein	Lock nut	M5 Cl.8	8	2349223400	
27	Vis	Screw	F/90 M5X15/15 4.8ZB	8	2303329060	
29	Avertisseur	Buzzer	24V	1	2440103120	
30	Relais	Relay	24V	1	2441801370	
31	Vis	Screw	H M10X25/25 8.8ZB	2	2331231560	
32	Rondelle à dents	Tooth lock washer	DE 10ZB	2	2351301110	
33	Rondelle plate	Flat washer	M10 U ZB	2	2351112090	
34	Vis moletée	Knurled screw	M6 L=12	1	2330003020	
35	Circuit imprimé	Printed circuit		1	118D160430	
36	Vis	Screw	HM 6X16/16 8.8	1	2331231310	
37	Ecrou	Nut	H M6 CL 8 ZB	1	2341221050	
38	Rondelle à dents	Tooth lock washer	DE 6ZB	1	2351301070	
39	Collier de fixation	Cable clip	Ø6	2	2389001500	
40	Vis	Screw	H M8X16/16 CL8.8 ZB	1	2331231400	
41	Rondelle à dents	Tooth lock washer	DE 8ZB	1	2351301090	
42	Ecrou	Nut	H M8 CL 8 ZB	1	2341221070	
43	Rondelle	Washer	Z12U	1	2351111080	
44	Carte pesage	Weighing card	S020037	1	2901001750	
45	Capot de protection	Protective cover		1	118P248210	
46	Vis	Screw	HM5x30-30 CL. 8.8 ZB	4	2331231240	
47	Rondelle à dents	Tooth lock washer	DEC 5 ZB	4	2351301060	

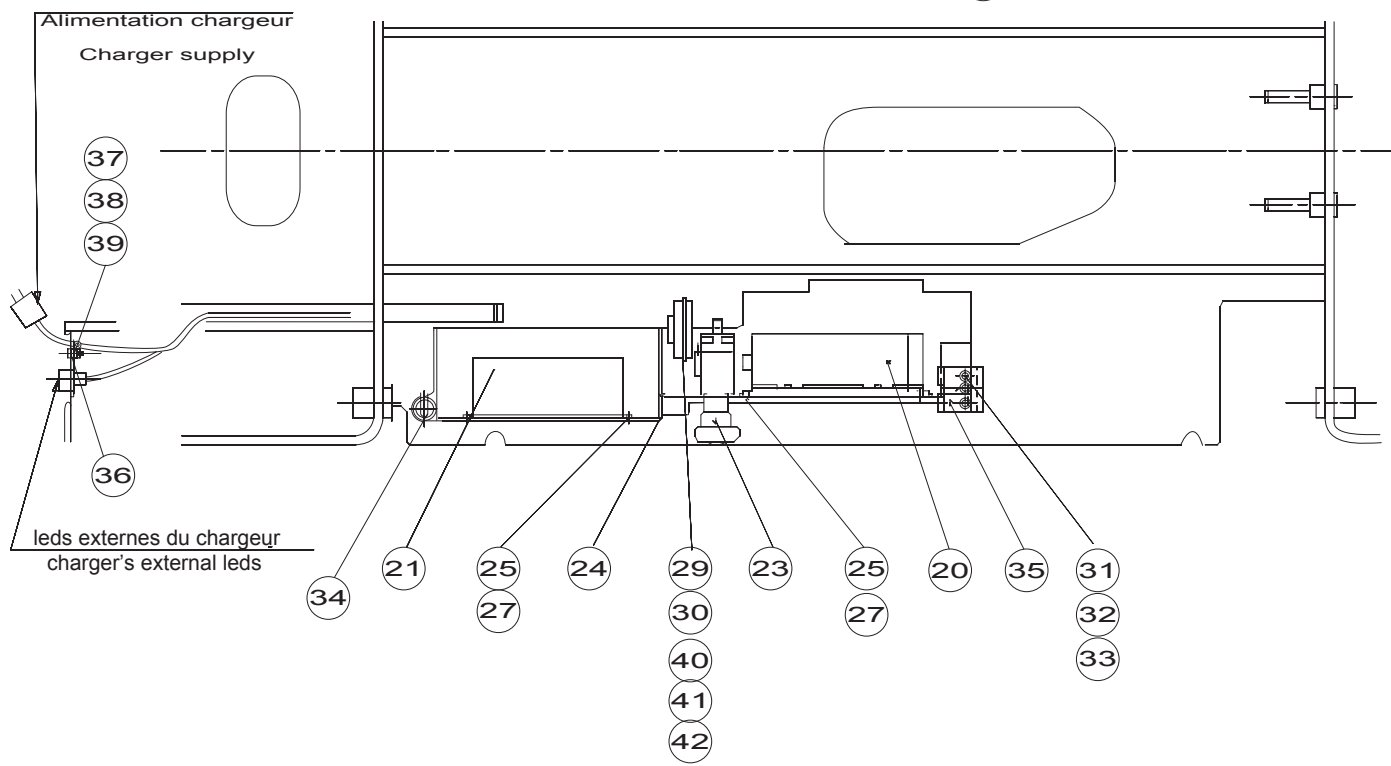
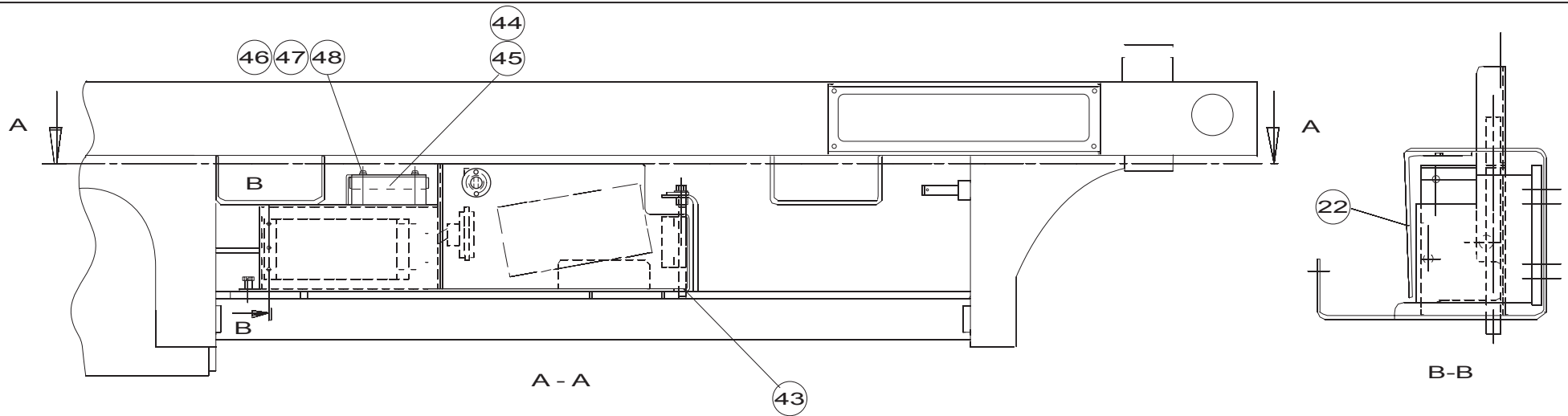

121P239410 B

F

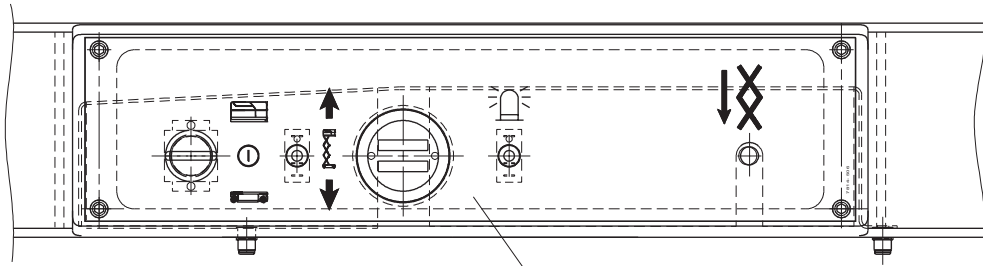

2 3 4

5

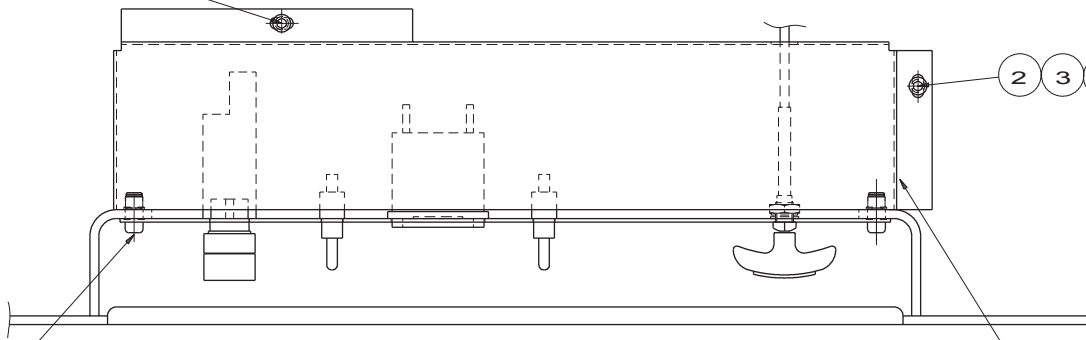

2

2 3 4

1

T

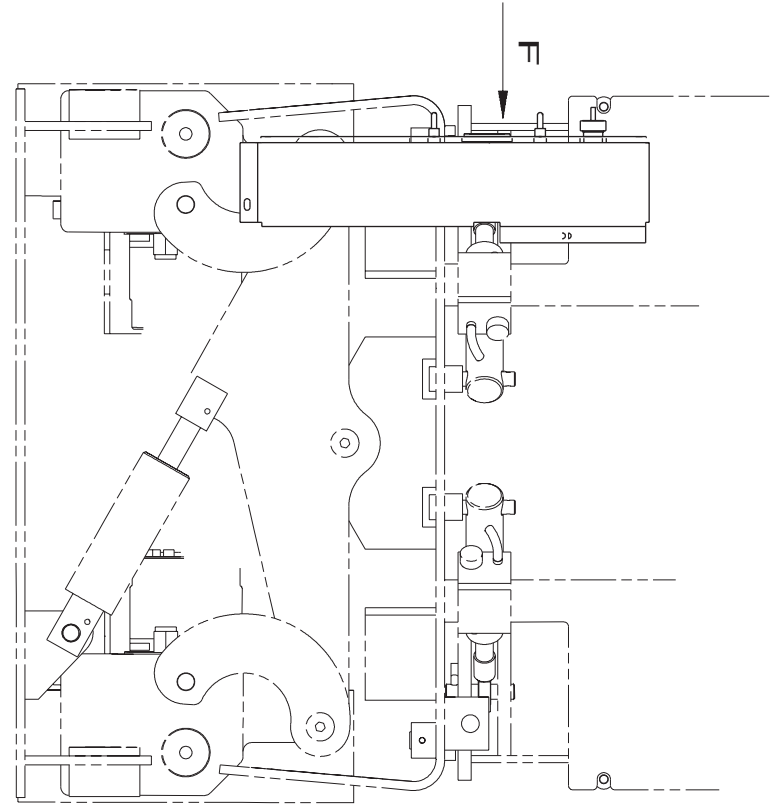

**▲ Ens. montage pupitre
Plate mounting unit**

Rep.	Désignation	Designation	Specification	Qty	Code	Up to / jusqu'à
1	Capot	hood		1	118C153400	
2	Vis	Screw	CHC M6X20/20 8.8	6	2308231490	
3	Rondelle plate	Flat washer	M6 U ZB	2	2351112050	
4	Rondelle à dents	Tooth lock washer	DE 6ZB	2	2351301070	

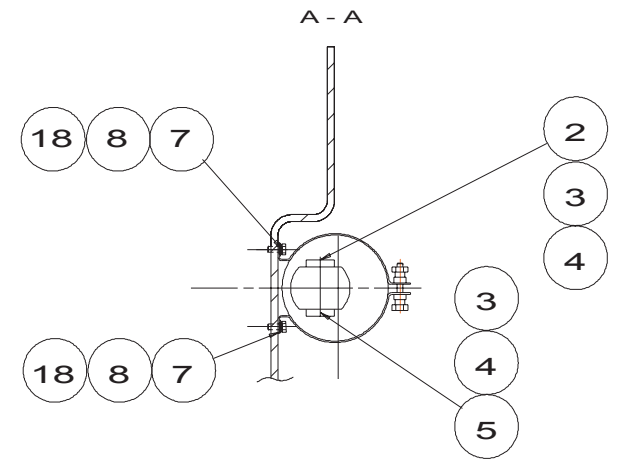
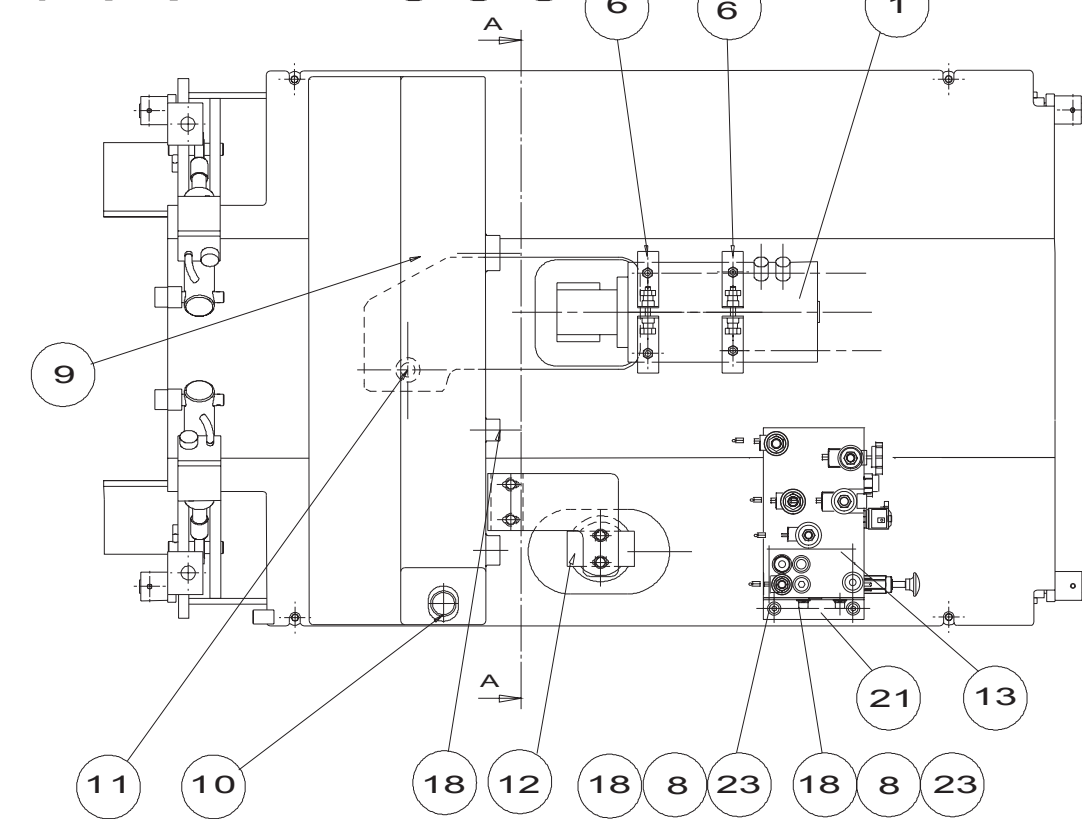
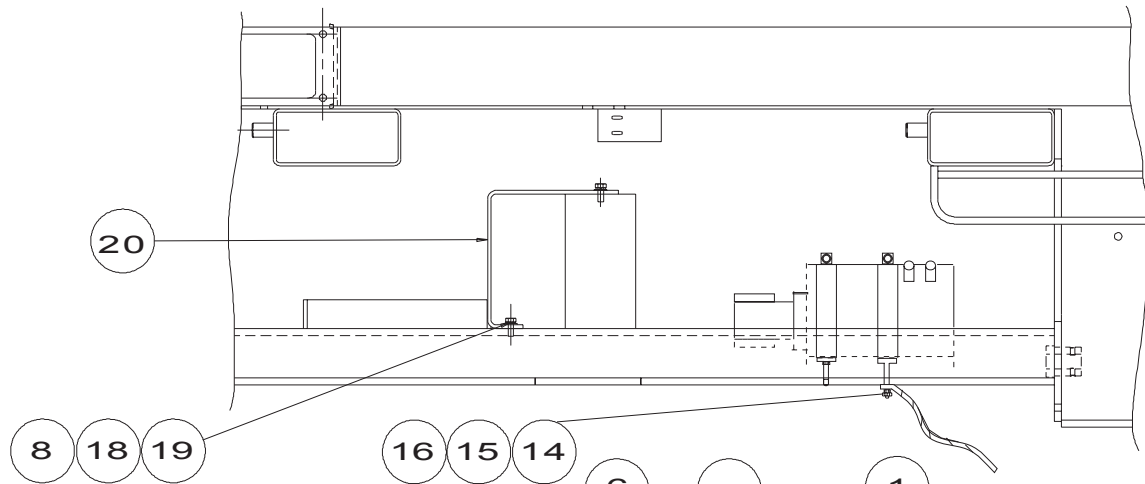

B16190c

▲ Centrale hydraulique
Central hydraulic plant

◀ **A6** ▶

Rep.	Désignation	Designation	Specification	Qty	Code	Up to / jusqu'à
1	Electropompe	Electropump	3KW 24V	1	2420703820	
2	Bride	Flange		1	2420202450	
3	Joint torique	O-ring	Ø22,22 x 2,62	2	2392004020	
4	Vis	Screw	CHC M6X20/20 8.8	8	2308231490	
5	Bride	Flange		1	2420202440	
6	Collier	Collar		2	2389003100	
7	Vis	Screw	H M8X20/20 CL8.8 ZB	3	2331231420	
8	Rondelle	Washer	GROWER W 8	11	2351201070	
9	Ens réservoir hydraul.	Hydraulic reservoir assembly	27L	1	1180607010	
12	Filtre à huile	Oil filter	3/4 BSPP	1	2427010430	
13	Bloc de distribution	Distribution block	MK4	1	2420212090	
14	Vis	Screw	H M8X30/30 CL8.8 ZB	1	2331231440	
15	Ecrou	Nut	M8 CL8ZB	1	2349221500	
16	Tresse de masse	Bonding jumper		1	2442004260	
18	Rondelle plate	Flat washer	M 8 U ZB	10	2351112070	
19	Vis	Screw	H M8X20/20 CL8.8 ZB	4	2331231420	
20	Patte de fixation	Retaining bracket		1	118C153240	
21	Patte de fixation	Retaining bracket		1	118C174180	
22	Rondelle plate	Flat washer	L8 U ZB	1	2351113070	
23	Vis	Screw	CHC M8X20/20 8.8	4	2308231690	

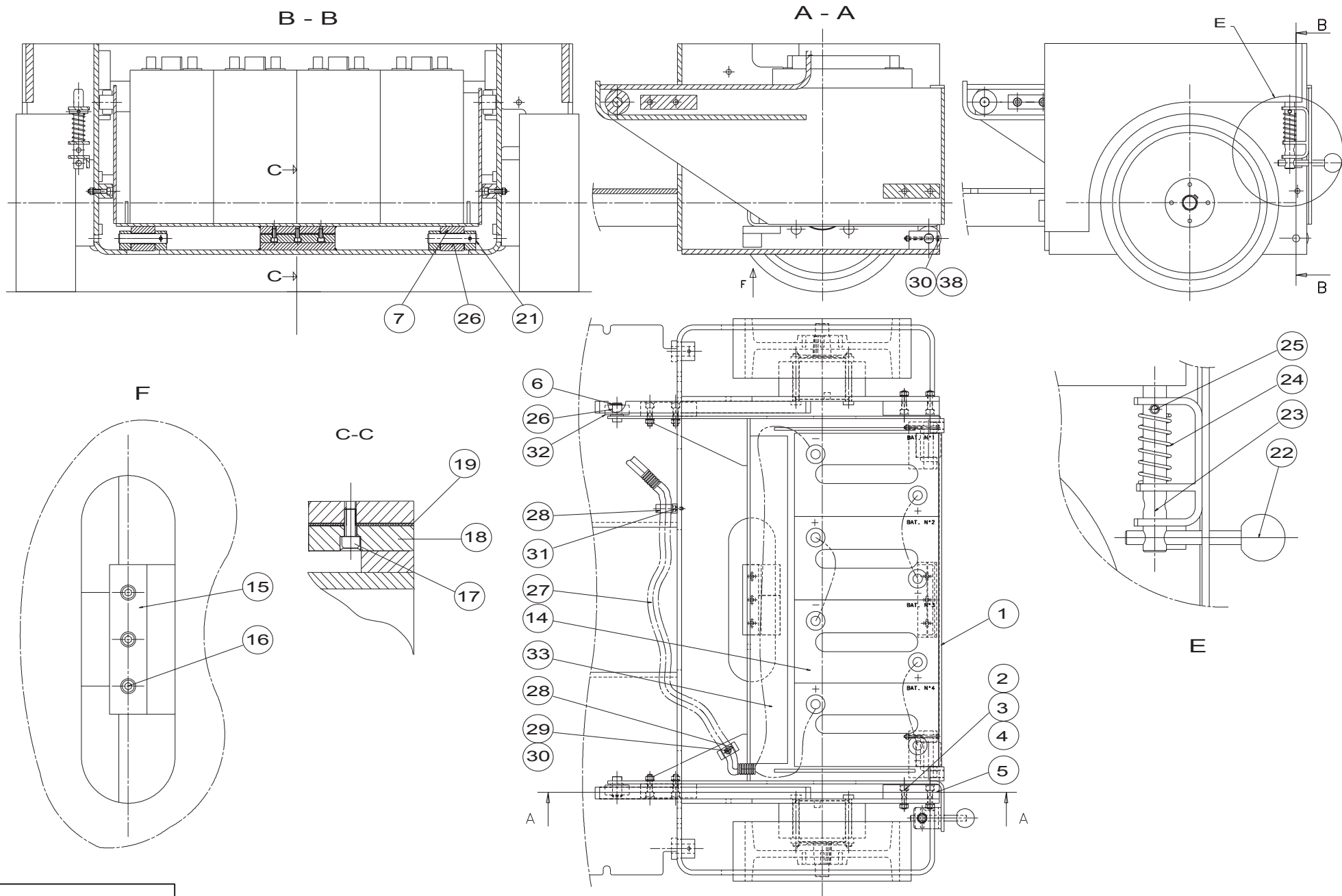

A14389 g

**▲ Coffre à batterie
Battery box**

◀ **A7**
1/2 ▶

Rep.	Désignation	Designation	Specification	Qty	Code	Up to / jusqu'à
99	Ens mont. bat. 250Ah	Battery unit		1	120A143890	
1	<i>Coffre à batterie</i>	<i>Battery box</i>		1	120B156700	
14	<i>Batterie de traction</i>	<i>Traction battery</i>		4	2440208350	
15	<i>Butée</i>	<i>Stop</i>		1	118C150460	
16	<i>Vis</i>	<i>Screw</i>	<i>CHC M8x30/30 8.8ZB</i>	3	2338231050	
17	<i>Vis</i>	<i>Screw</i>	<i>CHC M8X20/20 8.8</i>	3	2308231690	
18	<i>Patin</i>	<i>Pad</i>		1	118C150450	
19	<i>Cale épaisseur</i>	<i>Spacer</i>		1	118C150560	
2	<i>Vis</i>	<i>Screw</i>	<i>CHC M10X40/26 8.8</i>	8	2308231920	
21	<i>Axe</i>	<i>Pin</i>		2	120D159570	
22	<i>Boule</i>	<i>Ball</i>	<i>Ø40</i>	1	2420209380	
23	<i>Broche</i>	<i>Lock</i>		1	118C150490	
24	<i>Ressort</i>	<i>Spring</i>	<i>80 mm</i>	1	2421808300	
25	<i>Goupille</i>	<i>Pin</i>	<i>E 8-40</i>	1	2352212470	
27	<i>Gaine</i>	<i>Sheath</i>	<i>co-flex Ø23 lg=1m</i>	1	2440707070	
28	<i>Etrier</i>	<i>Caliper</i>	<i>Ø23</i>	2	2440501220	
29	<i>Vis</i>	<i>Screw</i>	<i>CHC M6X20/20 8.8</i>	1	2308231490	
3	<i>Rondelle à dents</i>	<i>Tooth lock washer</i>	<i>DE 10ZB</i>	8	2351301110	
30	<i>Ecrou</i>	<i>Nut</i>	<i>M6 CL8ZB</i>	3	2349221490	
31	<i>Vis</i>	<i>Screw</i>	<i>CHC M6X12/12 8,8</i>	1	2308231480	
32	<i>Galet</i>	<i>Roller</i>	<i>20.6mm</i>	2	118D159550	
33	<i>Cale</i>	<i>Chock</i>		1	120c154490	
38	<i>Vis</i>	<i>Screw</i>	<i>H M6X70/70 CL8.8 ZB</i>	1	2301231510	
4	<i>Ecrou</i>	<i>Nut</i>	<i>H M10 CL 8 ZB</i>	8	2341221080	
5	<i>Patin</i>	<i>Pad</i>		4	118C150440	
6	<i>Circlips</i>	<i>Circlips</i>	<i>2000 Ø20 E</i>	2	2472001170	

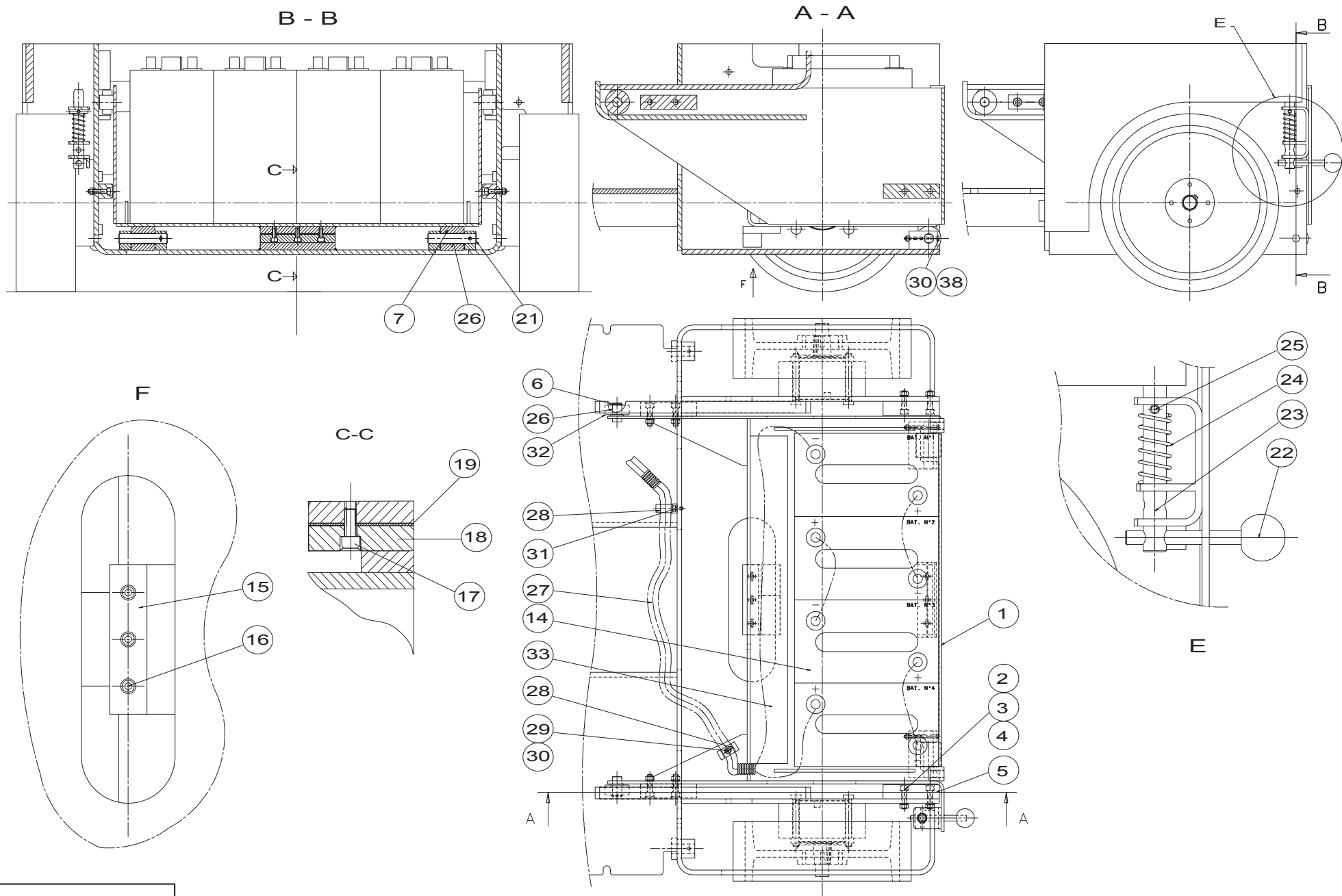

A14389 g

**▲ Coffre à batterie
Battery box**

Rep.	Désignation	Designation	Specification	Qty	Code	Up to / jusqu'à
7	<i>Galet</i>	<i>Roller</i>	<i>LG=50</i>	2	120D159560	

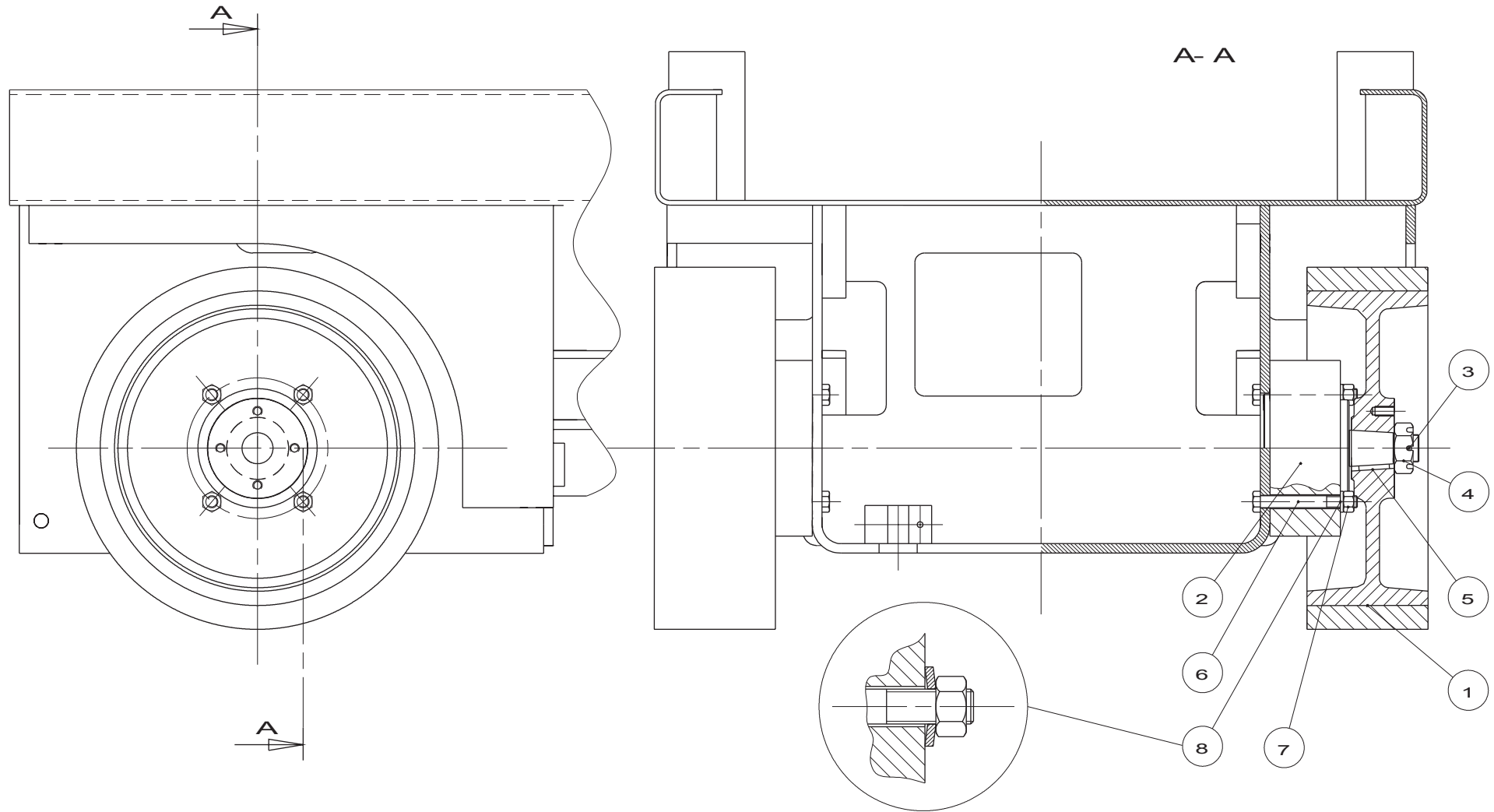

B15650d

**▲ Essieu AR
Rear axle**

◀ A8 ▶

Rep.	Désignation	Designation	Specification	Qty	Code	Up to / jusqu'à
1	Roue	Wheel	15" X 5"	2	118B156380	
2	Frein	Brake		2	2420602750	
3	<i>Goupille</i>	<i>Pin</i>		1	2352901390	
4	<i>Ecrou</i>	<i>Nut</i>		1	2349223250	
5	<i>Clavette</i>	<i>Key</i>		1	2353901140	
6	Vis	Screw	H 1/2" UNC 4" CL 8.8	8	2321311550	
7	Ecrou	Nut	H1/2" UNC C18ZB	8	2349222970	
8	Rondelle élastique	Rubber washer	M12	8	2351902530	

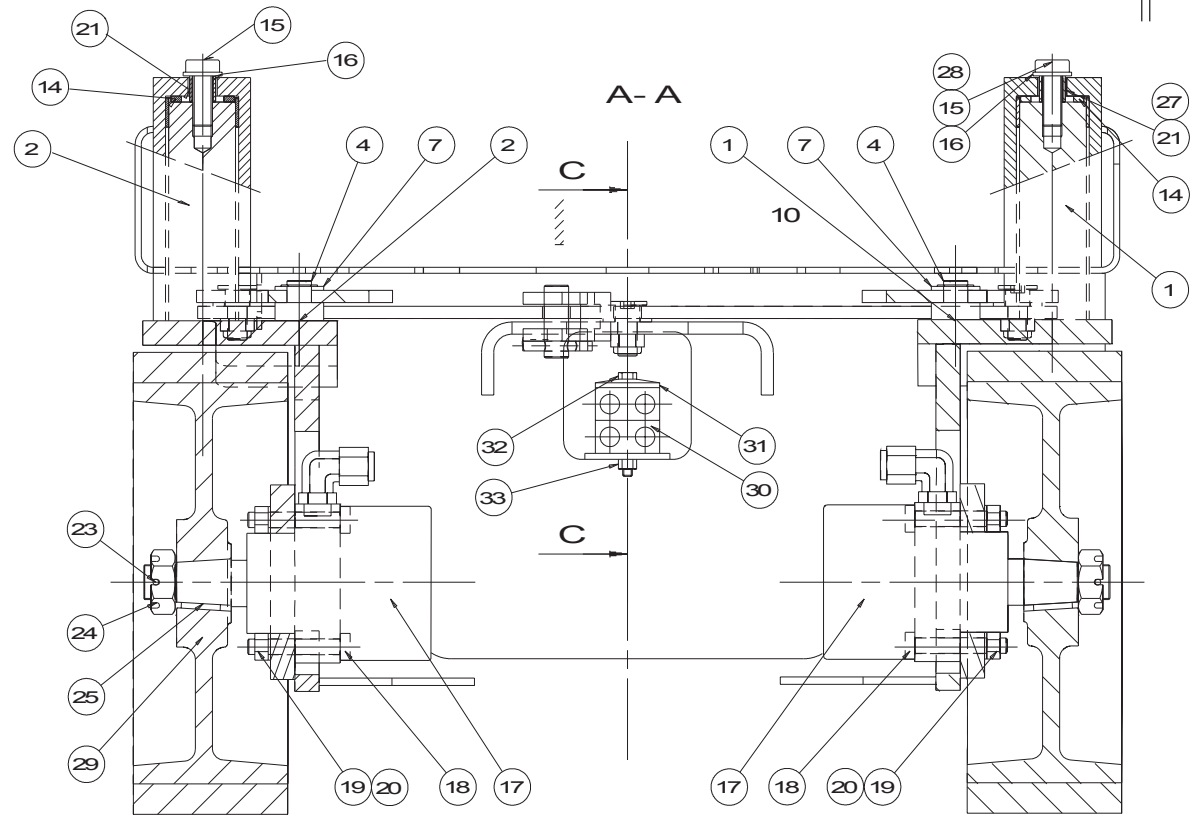
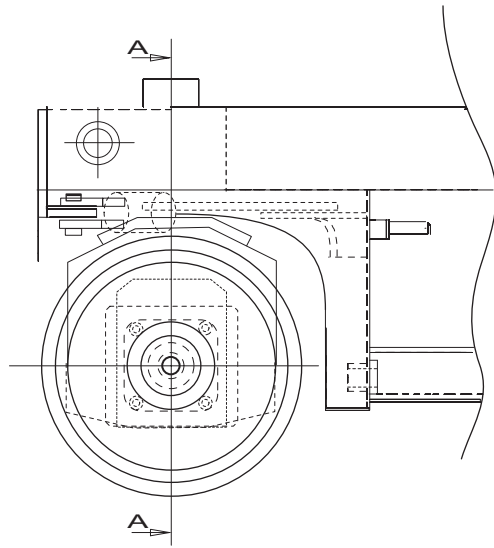
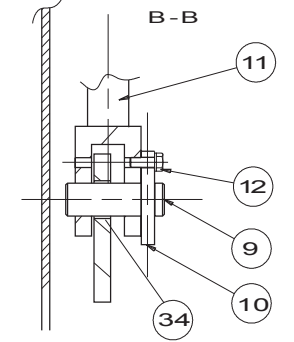
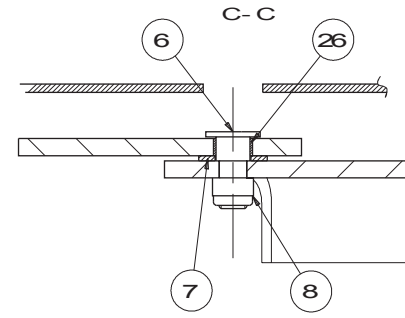
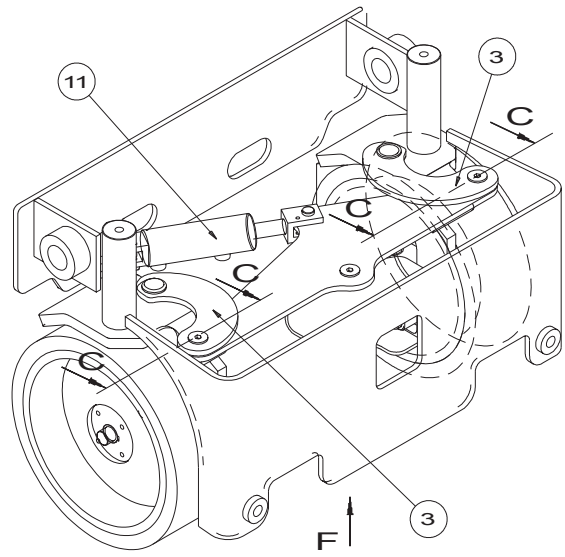
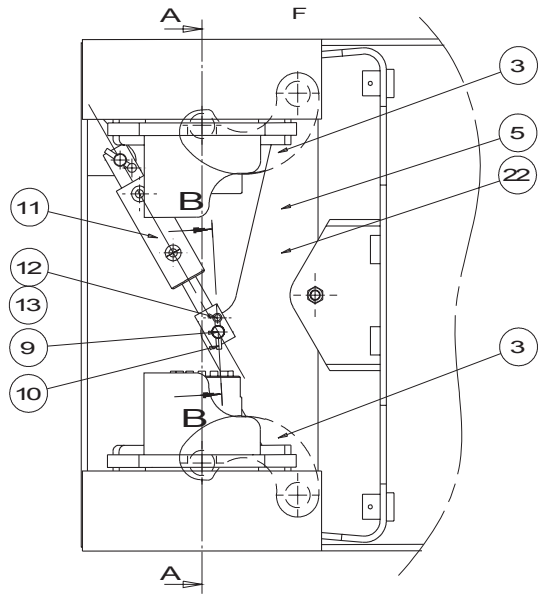

B 15649 h

▲ **Essieu moto-directeur**
Motor guiding axle

◀ **A9**
1/2 ▶

Rep.	Désignation	Designation	Specification	Qty	Code	Up to / jusqu'à
1	Pivot direction	Direction pivot		1	118B156390	
2	Pivot gauche	Left pivot		1	118B156400	
3	Biellette	Link rod	SP.5044	2	118C149420	
	<i>Bague</i>	<i>Ring</i>	<i>MB 20/10 DU</i>	2	<i>2390150790</i>	
4	Circlips	Circlips	2000 Ø20 E	2	2472001170	
6	Vis	Screw		3	118C150570	
7	Rondelle plate	Flat washer	M20 U ZB	5	2351112150	
8	Ecrou	Nut	M16 CL8ZB	3	2349221540	
9	Axe vérin de direction	Steering cylinder pin		2	118D159380	
10	Chape mâle lisse	Smooth male slot	Ø8 50mm	2	173D158320	
11	Vérin de direction	Steering cylinder	SP.5093	1	118C149370	
12	Vis	Screw	HM 6X16/16 8.8	2	2331231310	
13	Rondelle à dents	Tooth lock washer	DE 6ZB	2	2351301070	
14	Rondelle	Washer	Ø35 X 52 - 3,5	2	2351902510	
16	Rondelle plate	Flat washer	L16N ZB	2	2351123130	
17	Moteur hydraulique	Hydraulic motor	S5725	2	2431203590	
18	Vis	Screw	H 1/2" UNC 3" 8.8	8	2321311560	
19	Ecrou	Nut	H1/2" UNC CI8ZB	8	2349222970	
20	Rondelle élastique	Rubber washer	M12	8	2351902530	
22	Levier de direction	Direction lever		1	118B156530	
26	<i>Bague</i>	<i>Ring</i>	<i>MB 20/10 DU</i>	1	<i>2390150790</i>	
34	<i>Bague</i>	<i>Ring</i>	<i>FMB 20-11,5 DU</i>	1	<i>2390150400</i>	
27	Entretoise	Brace		2	118D159500	
28	Vis	Screw	H M16X90/38 8.8	2	2301232450	
29	Collier	Collar	216/16 PP	2	2389003250	
30	Plaque de protection	Protective plate	GD2-D	1	2421608490	

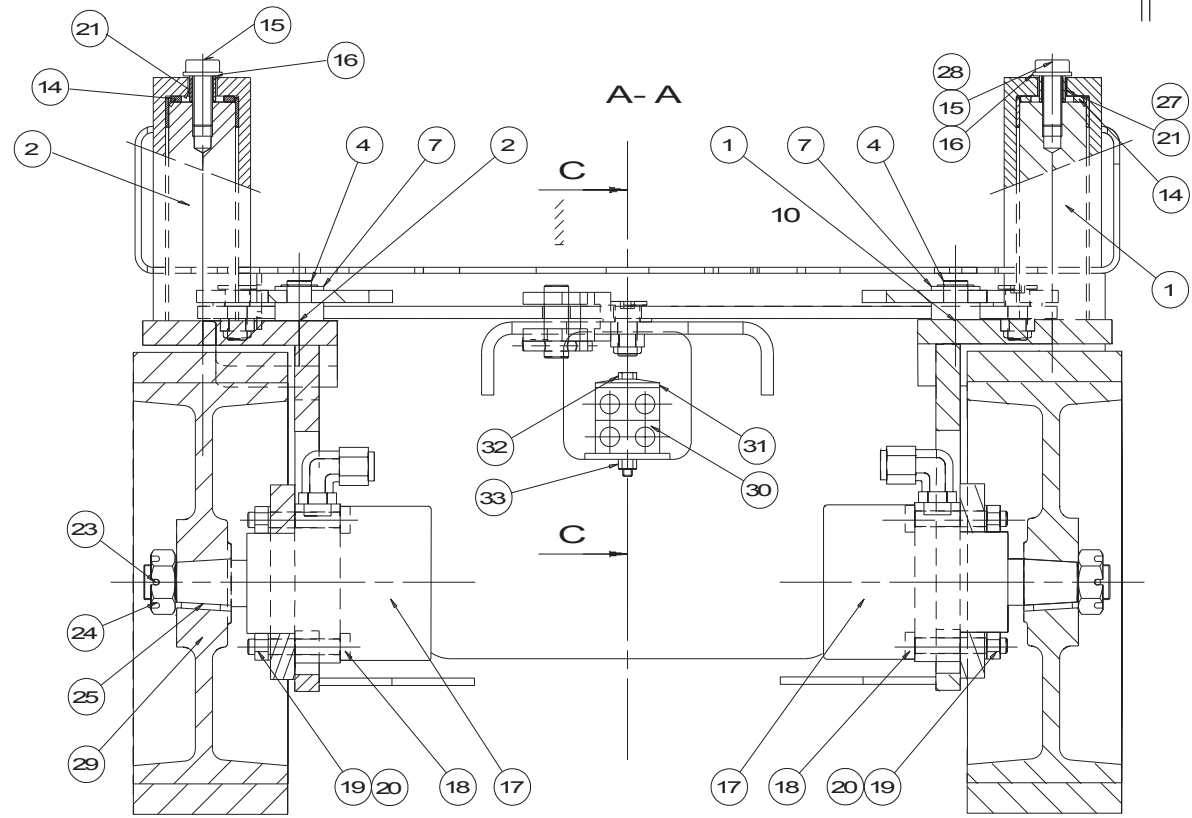
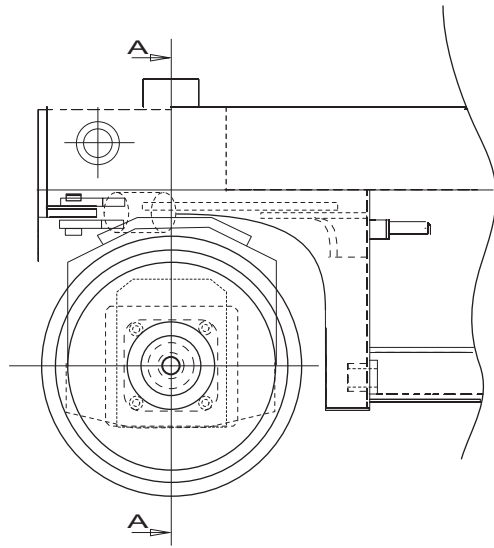
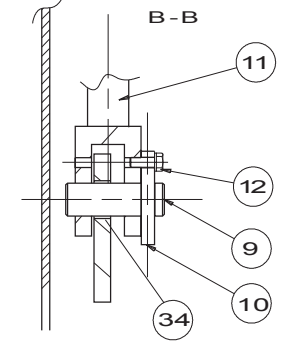
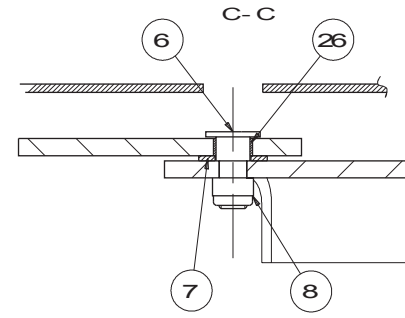
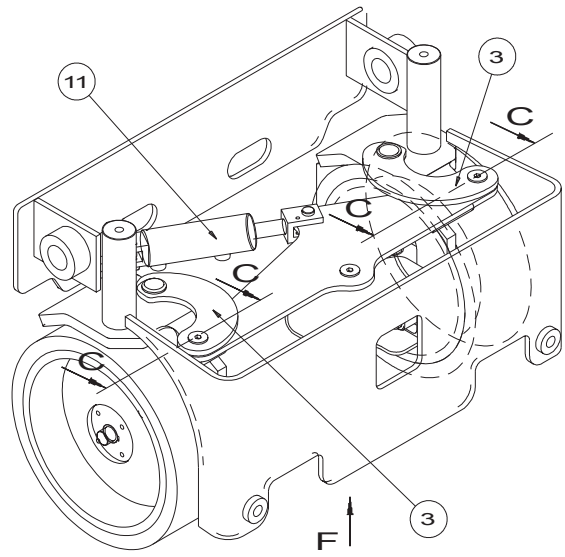
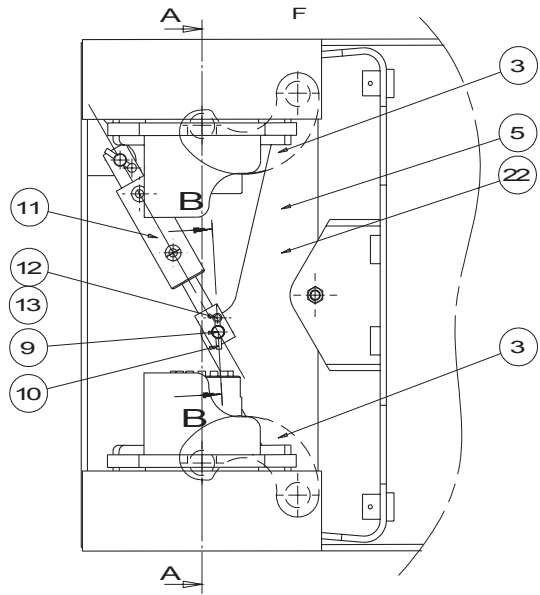

B 15649 h

▲ **Essieu moto-directeur**
Motor guiding axle

Rep.	Désignation	Designation	Specification	Qty	Code	Up to / jusqu'à
31	Vis	Screw	H M8X80/22 CL8.8 ZB	1	2301231750	
32	Ecrou	Nut	M8 CL8ZB	1	2349221500	

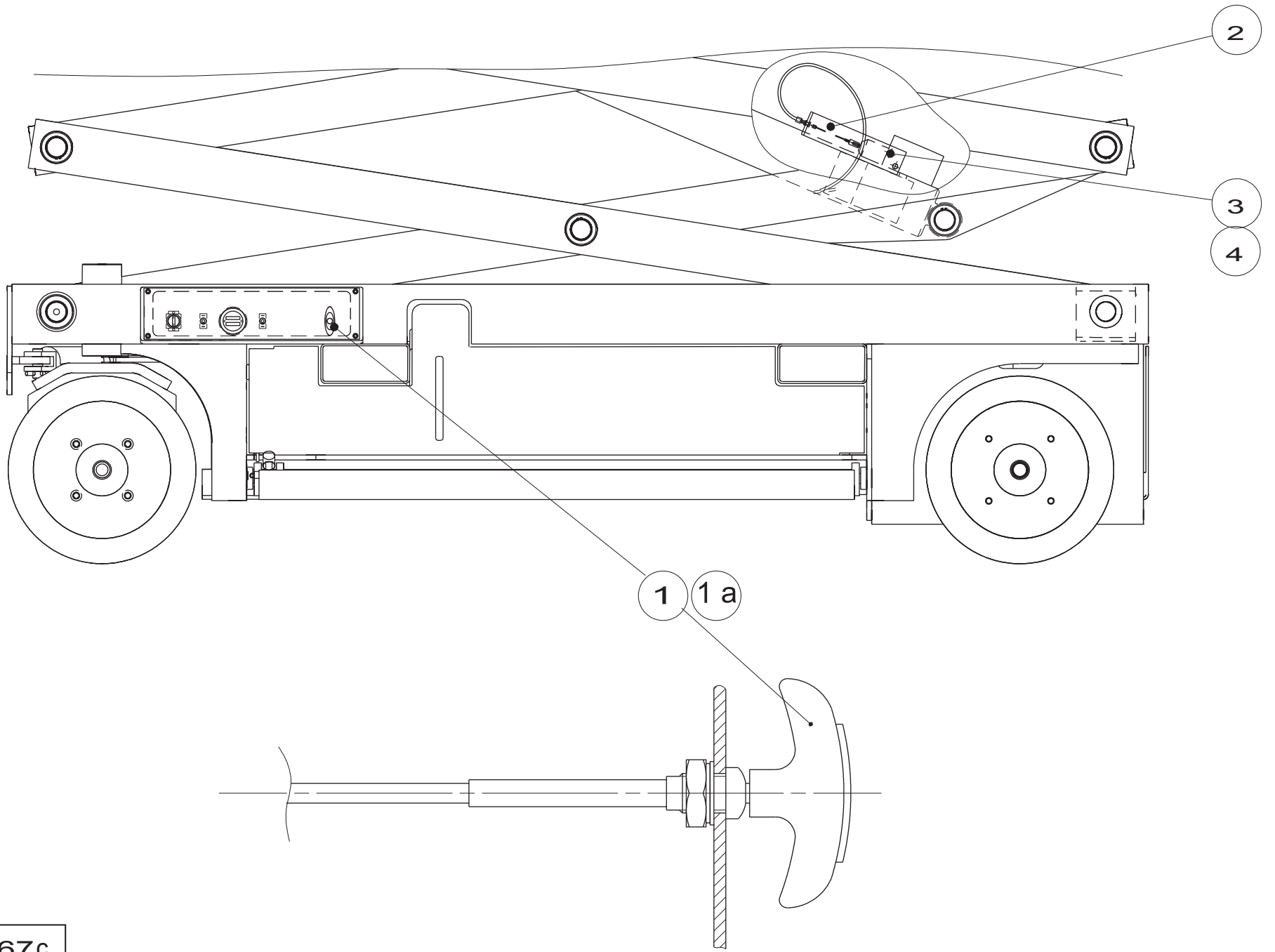

B15667c

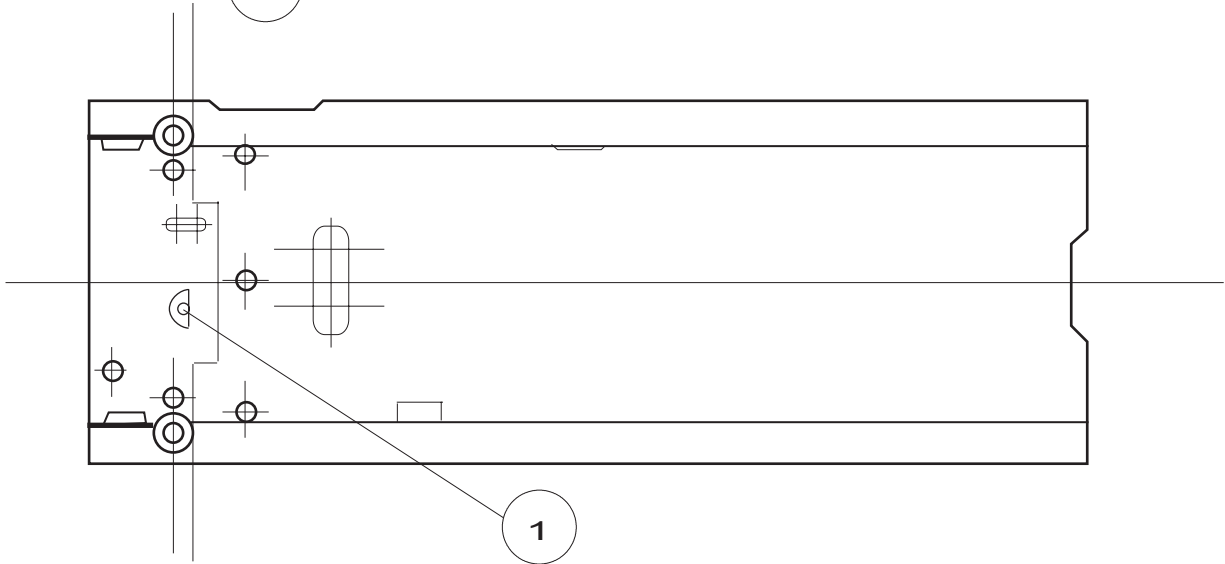
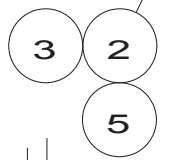
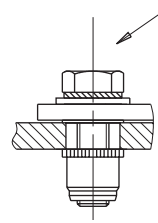
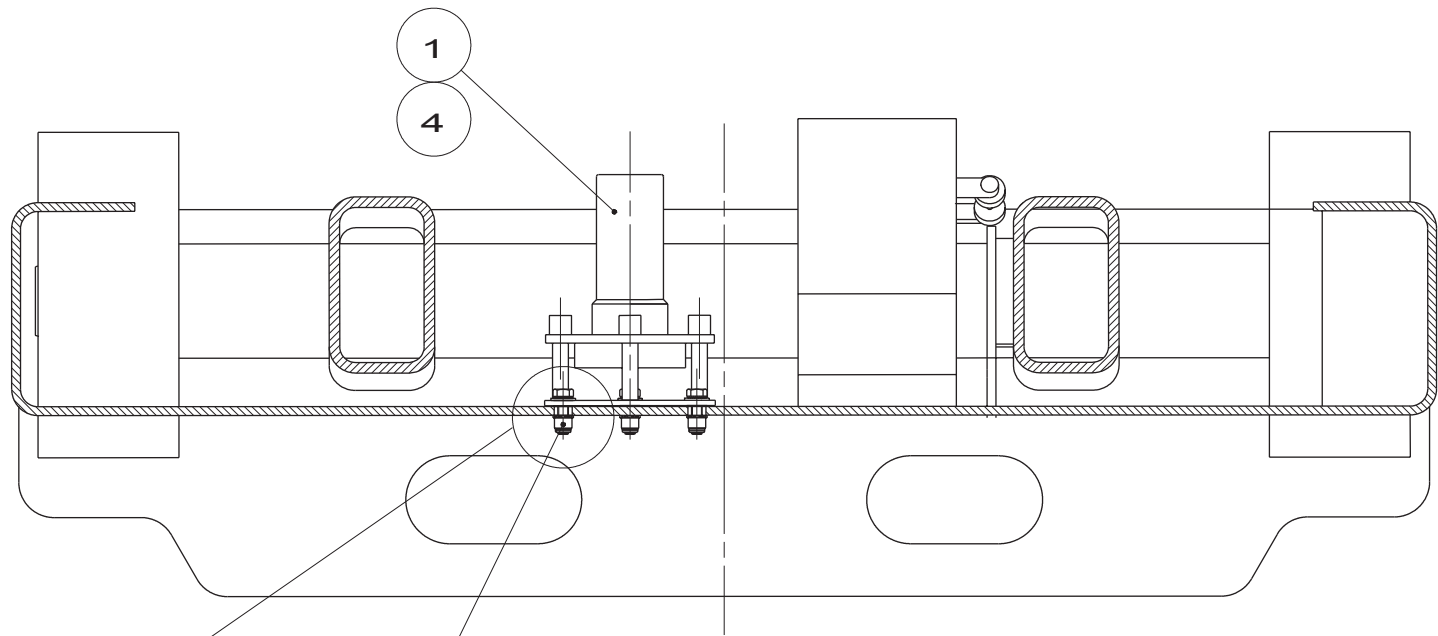

C15330 b

▲ **Détecteur de dévers**
Tilt detector

◀ **A11** ▶

Rep.	Désignation	Designation	Specification	Qty	Code	Up to / jusqu'à
1	Détecteur de dévers	Tilt detector	3°	1	2440203480	
2	Vis	Screw	HM 6X20/20 8.8	3	2331231330	
3	Rondelle plate	Flat washer	M6 U ZB	3	2351112050	
4	Câblage	Cables	PQ	1	118C153260	
	Cosse	<i>Lug</i>	Ø4 (<i>douille</i>)	2	2440305560	
	Cosse	<i>Lug</i>	Ø4 (<i>fiche</i>)	1	2440305570	
5	Rondelle à dents	Tooth lock washer	DE 6ZB	3	2351301070	

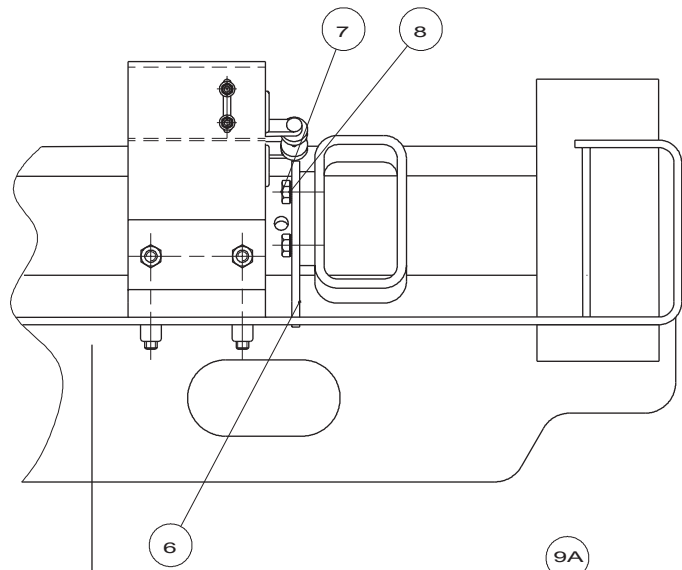

H12 N

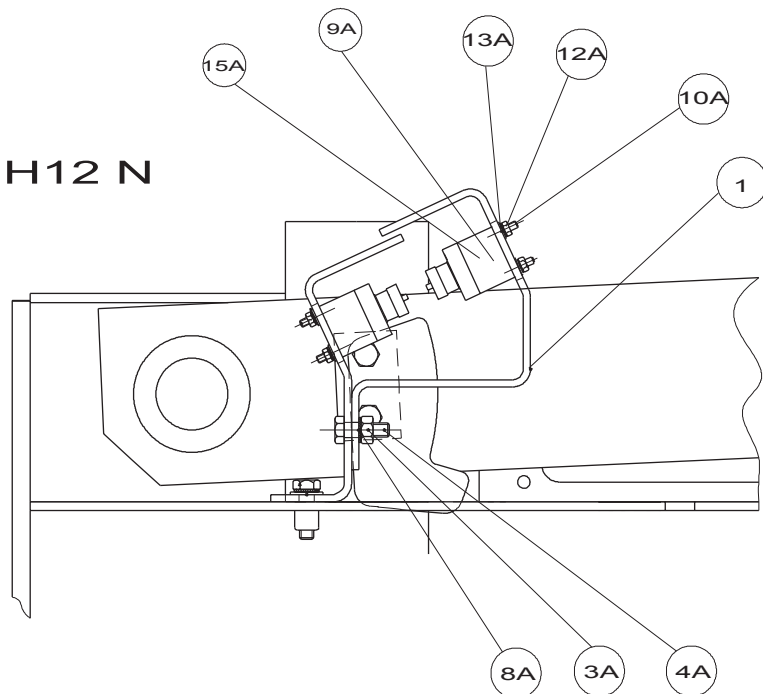

Toutes machines sauf H12N
All machines except H12N

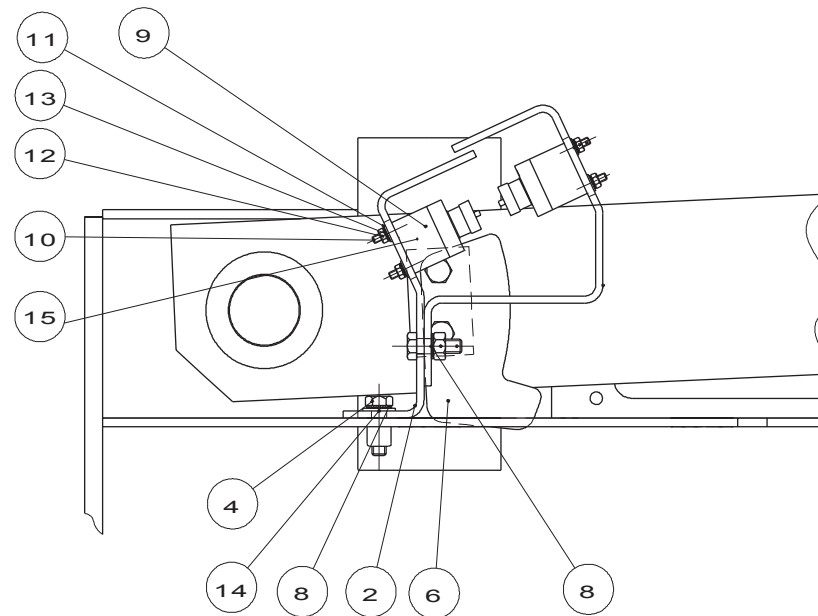

▲ **Coupure G.V.**
High Speed cut-off

◀ **A12** ▶

Rep.	Désignation	Designation	Specification	Qty	Code	Up to / jusqu'à
2	Support	Holder		1	118C150340	
4	Vis	Screw	H M8X25/25 CL8.8 ZB	2	2331231430	
6	Came	Cam		1	118C150330	
7	Vis	Screw	H M8X16/16 CL8.8 ZB	2	2331231400	
8	Rondelle à dents	Tooth lock washer	DE 8ZB	4	2351301090	
10	Vis	Screw	CHC M4X35/20 8.8	2	2308231220	
11	Rondelle plate	Flat washer	M4U ZB	2	2351112030	
12	Ecrou	Nut	H M4 CL 8 ZB	2	2341221030	
13	Rondelle à dents	Tooth lock washer	DE 4ZB	2	2351301050	
14	Rondelle plate	Flat washer	M 8 U ZB	2	2351112070	

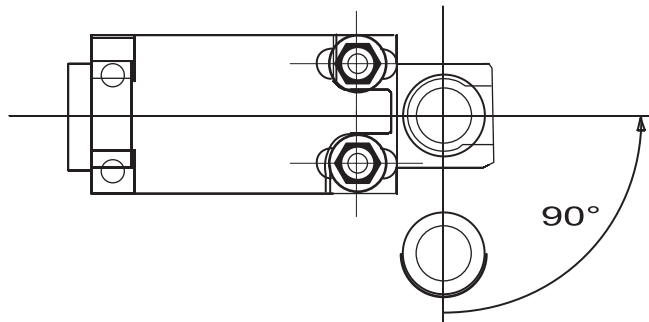
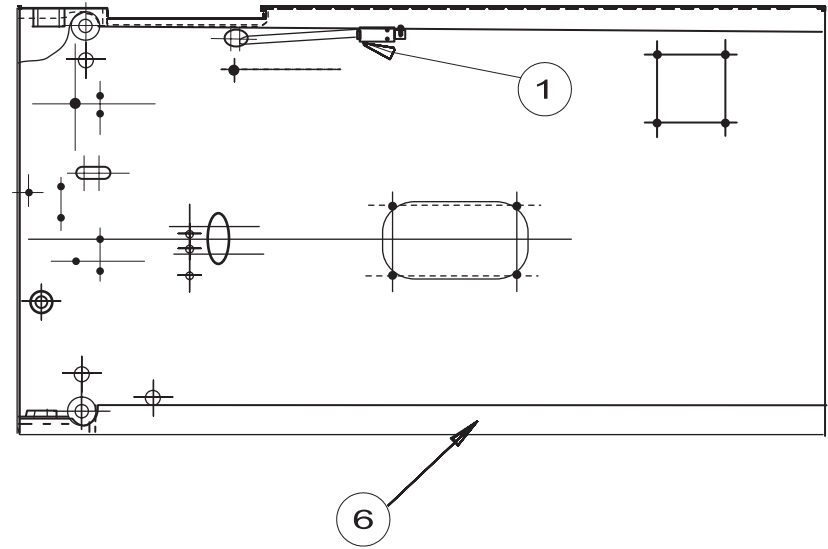
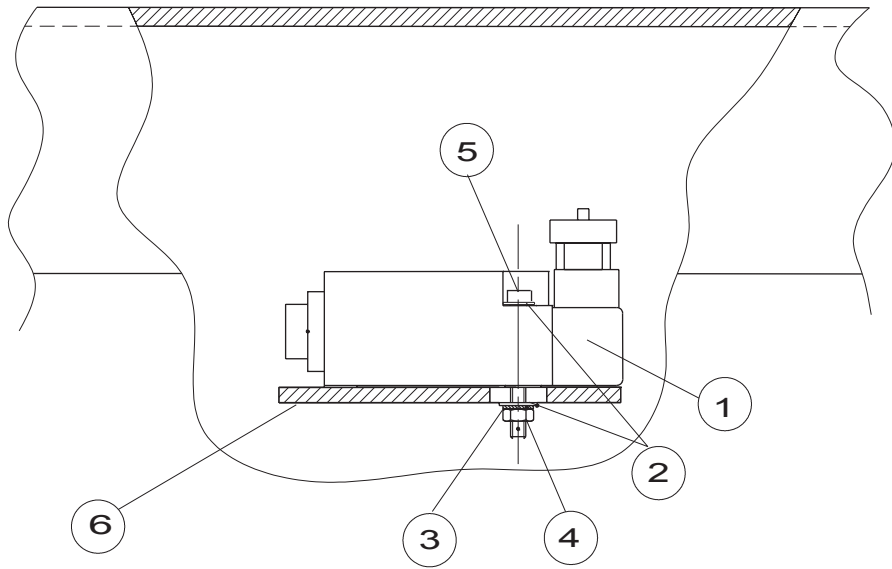

C15043c

▲ **Fin de course levage**
End of travel

Rep.	Désignation	Designation	Specification	Qty	Code	Up to / jusqu'à
1	Interrupteur position	Position switch		1	2440901490	
2	Rondelle plate	Flat washer	M4U ZB	4	2351112030	
3	Rondelle à dents	Tooth lock washer	DE 4ZB	2	2351301050	
4	Ecrou	Nut	H M4 CL 8 ZB	2	2341221030	
5	Vis	Screw	CHC M4X35/20 8.8	2	2308231220	

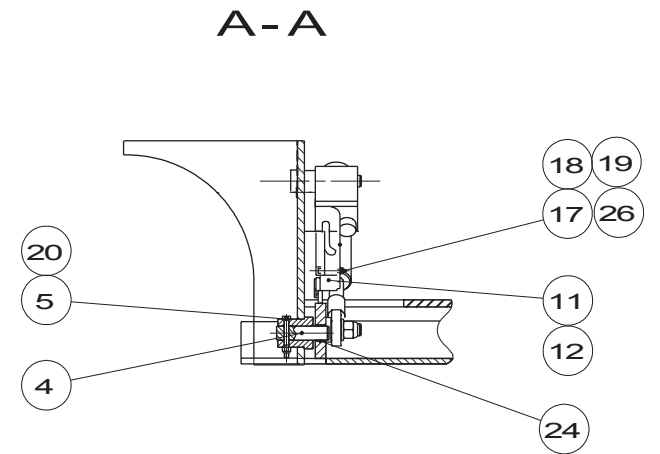
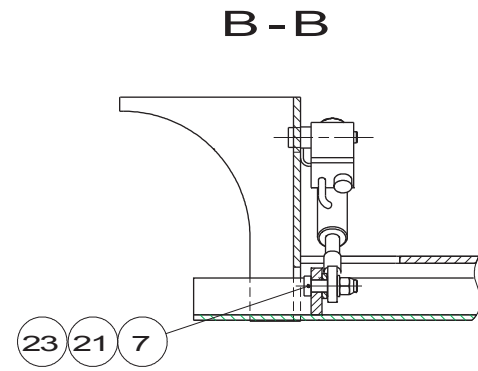
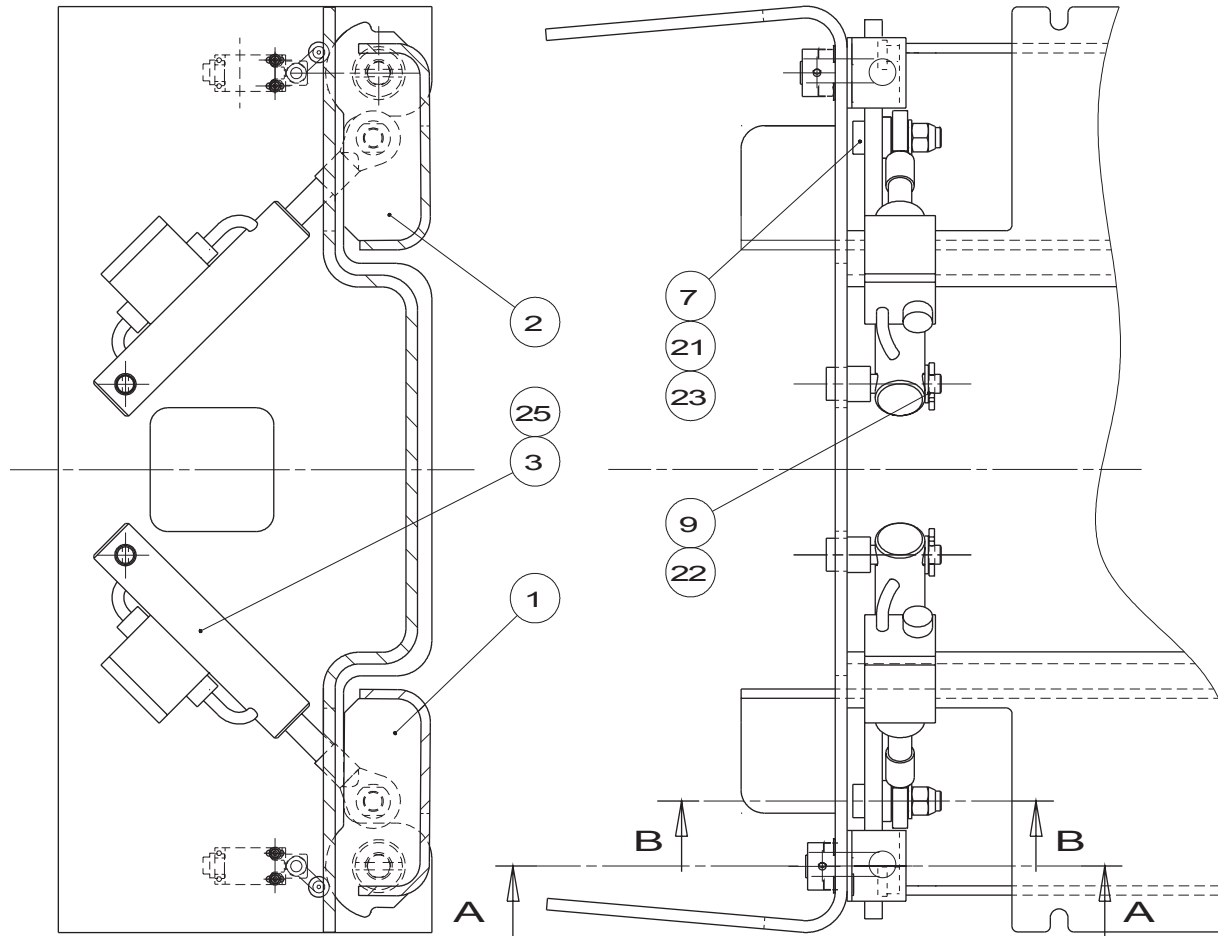

B15845 d

▲ **Pothole**
Anti-tipping over device

◀ **A14** ▶

Rep.	Désignation	Designation	Specification	Qty	Code	Up to / jusqu'à
1	Pothole gauche	Left anti-tipping over device		1	118B156720	
24	<i>Bague</i>	<i>Ring</i>	<i>MB 20 15 DU</i>	2	2390150340	
1	Pothole droit	Right anti-tipping over device		1	118B156710	
24	<i>Bague</i>	<i>Ring</i>	<i>MB 20 15 DU</i>	2	2390150340	
3	Vérin de pothole	Pothole cylinder		2	118C174240	
25	<i>Bague</i>	<i>Ring</i>	<i>MB160 DU</i>	2	2390150800	
4	Axe	Pin		4	118D159400	
5	Vis	Screw	HM6 50x50	4	2331231380	
7	Vis	Screw		2	118D159580	
9	Rondelle plate	Flat washer	M16 U ZB	2	2351112130	
11	Interrupteur position	Position switch		1	2440901490	
12	Presse-étoupe réd.		13/7	1	2441613010	
17	Rondelle à dents	Tooth lock washer	DE 4ZB	4	2351301050	
18	Ecrou	Nut	H M4 CL 8 ZB	4	2341221030	
19	Vis	Screw	CHC M4X40/20 8.8	5	2308231230	
20	Ecrou	Nut	M6 CL8ZB	4	2349221490	
21	Rondelle plate	Flat washer	M16 U ZB	2	2351112130	
22	Goupille	Pin	V 5-36 NF	2	2352110990	
23	Ecrou	Nut	M16 CL8ZB	2	2349221540	
26	Rondelle plate	Flat washer	M4U ZB	4	2351112030	

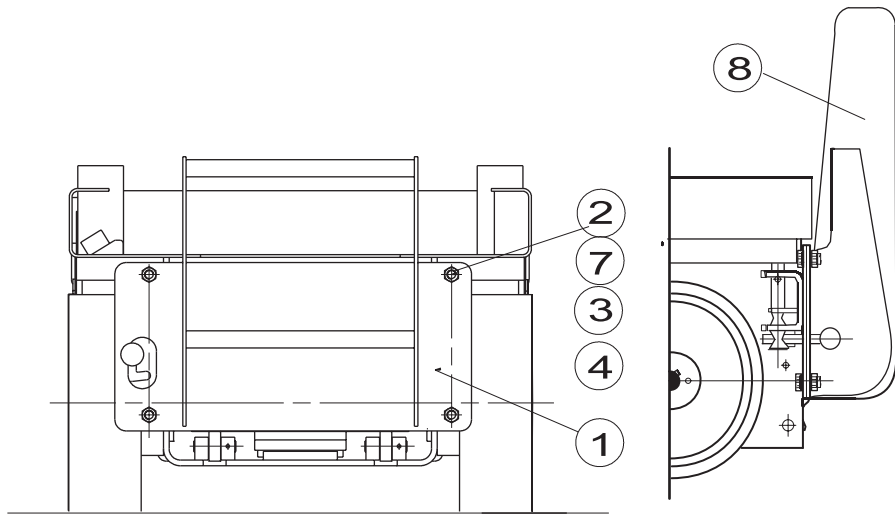

HS8N - H10N

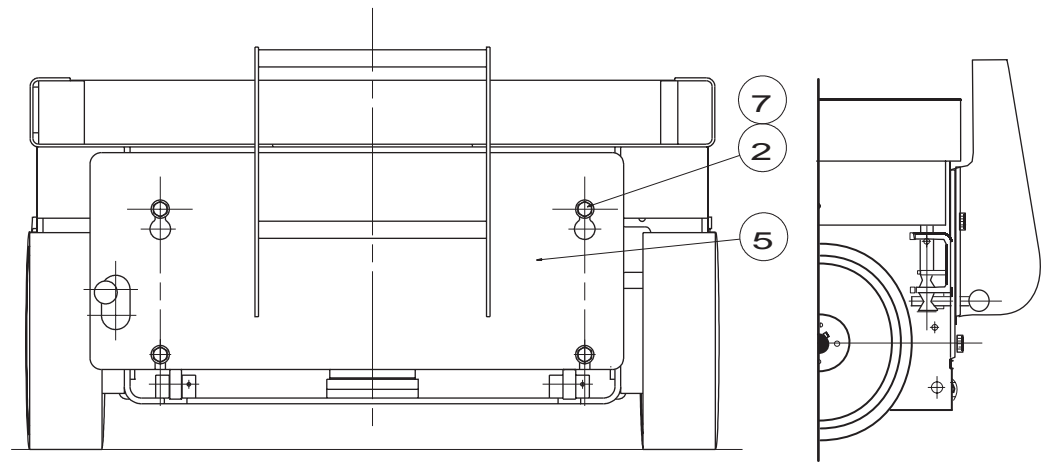

HS8W

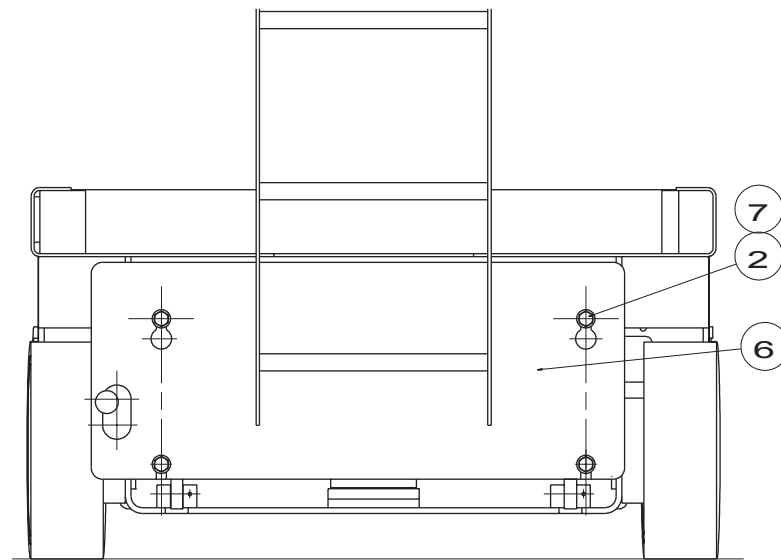

H10S - H12N

**▲ Marche pied
Step**

◀ **A15** ▶

Rep.	Désignation	Designation	Specification	Qty	Code	Up to / jusqu'à
2	Vis	Screw	H M16X30/30 CL8.8 ZB	4	2331232200	
6	Marche pied	Step		1	120B156740	
7	Rondelle plate	Flat washer	M16 U ZB	4	2351112130	

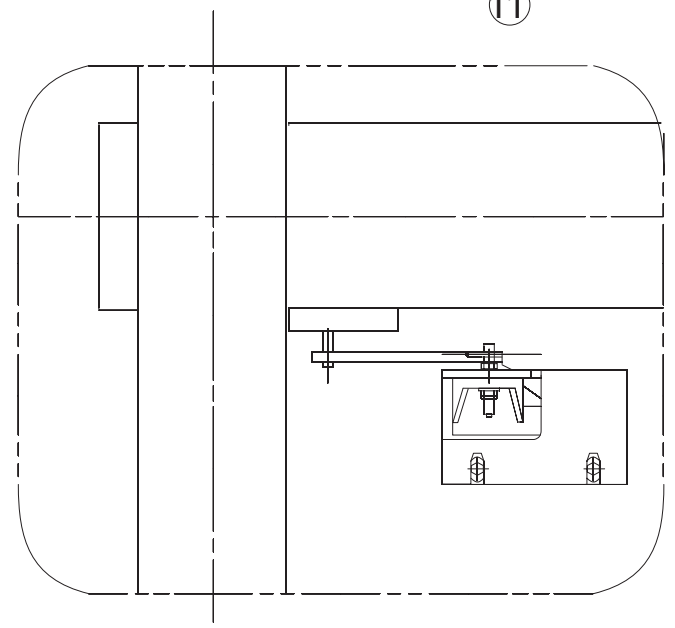
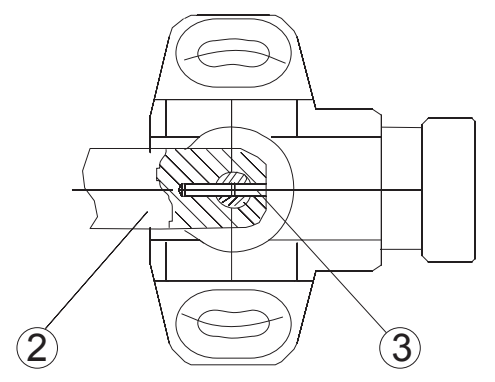
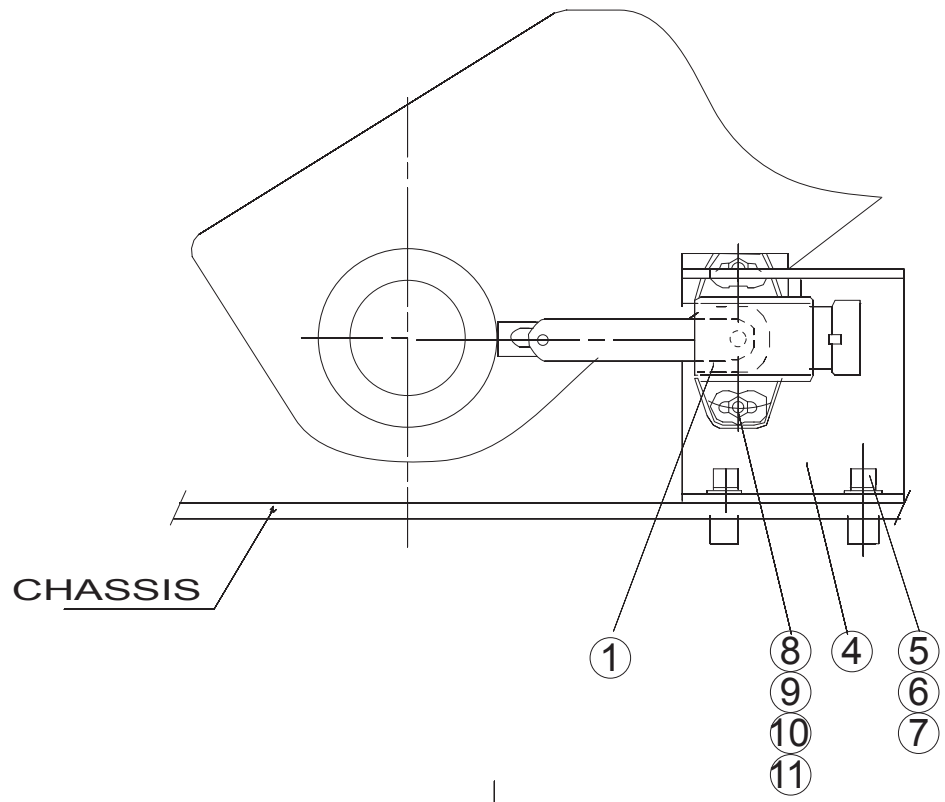

118P241630C

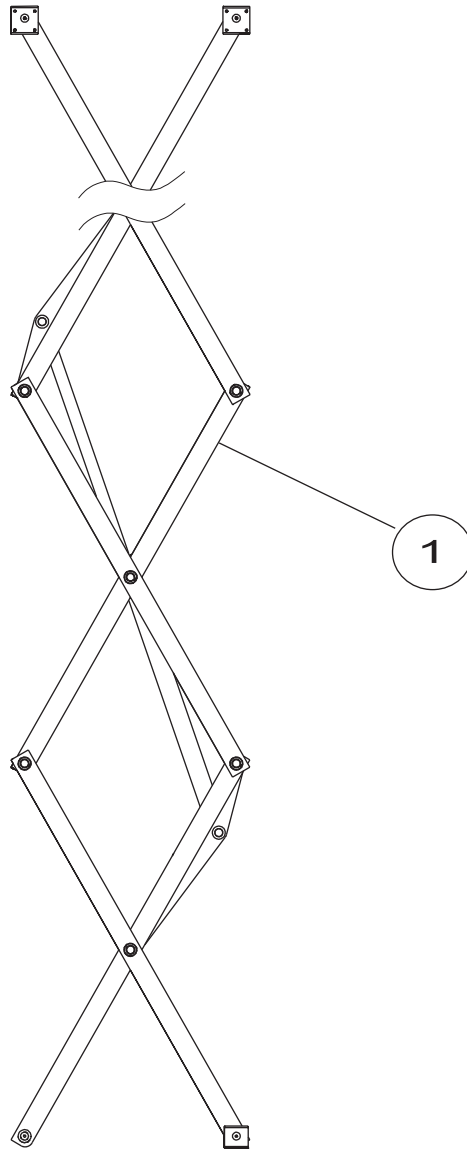

D16077

▲ **Ensemble ciseaux**
Scissor lift platform unit

Rep.	Désignation	Designation	Specification	Up to / jusqu'à
1	Ensemble ciseaux	Scissor lift platform unit		

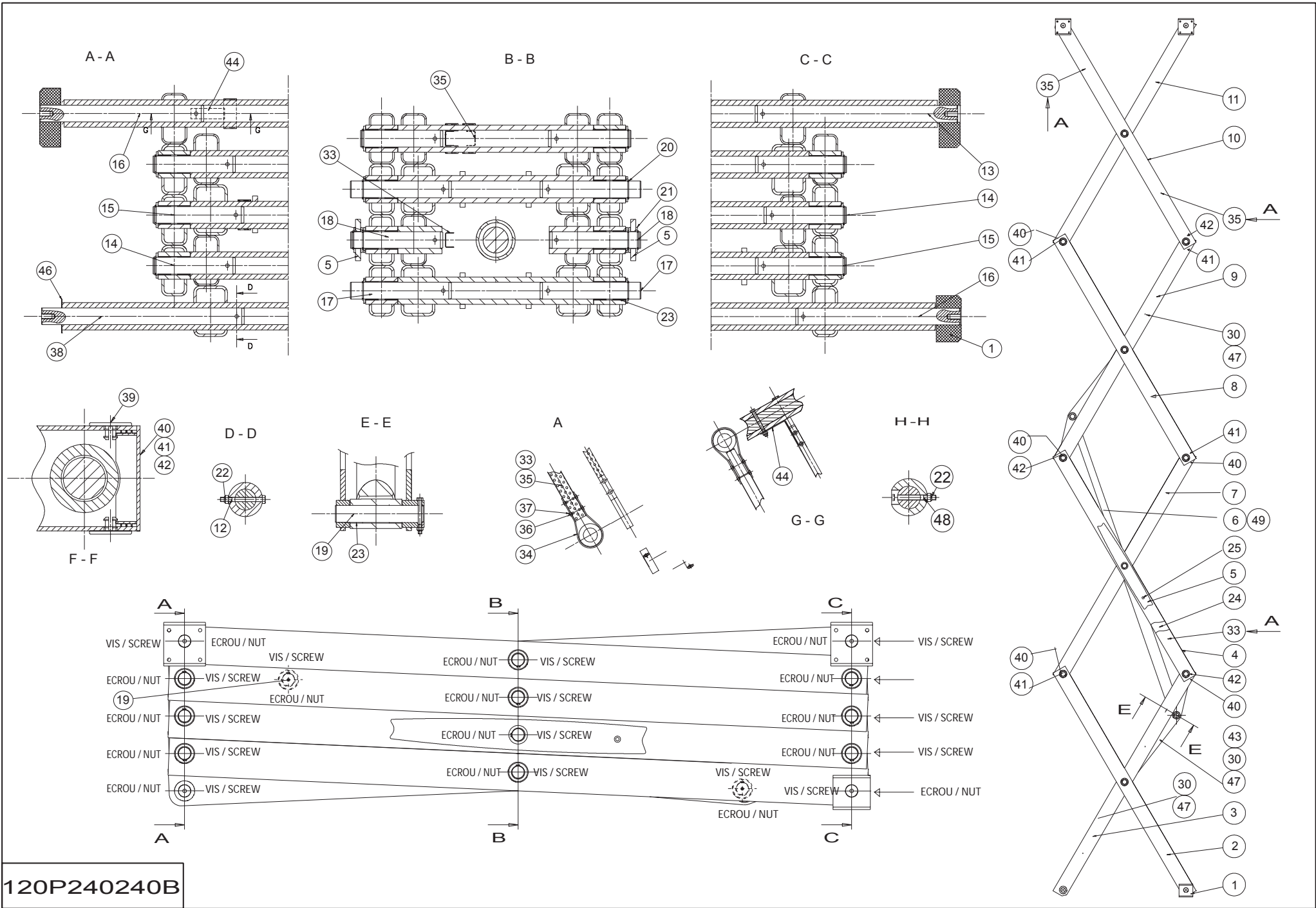

120P240240B

▲ **Ensemble ciseaux**
Scissor lift platform unit

◀ **B1**
1/2 ▶

Rep.	Désignation	Designation	Specification	Qty	Code	Up to / jusqu'à
1	Patin	Pad		2	118D159370	
2	Bras extérieur	Exterior arm	1	1	120B156040	
23	<i>Bague</i>	<i>Ring</i>	<i>PM 40/30 DX SIC</i>	8	<i>2390150450</i>	
3	Bras intérieur	Interior arm	1	1	121P239140	
4	Bras extérieur droit	Exterior right arm	2	2	120B156050	
	<i>Bague</i>	<i>Ring</i>	<i>PM 40/30 DX SIC</i>	6	<i>2390150450</i>	
5	Béquille	Support		2	120C149350	
6	Vérin de levage	lift cylinder	65/90	1	120P248780	
	<i>Bague</i>	<i>Ring</i>	<i>PM 40/30 DX SIC</i>	4	<i>2390150450</i>	
7	Bras intérieur	Interior arm	2	1	120B155910	
8	Bras extérieur	Exterior arm	3	2	120B156080	
	<i>Bague</i>	<i>Ring</i>	<i>PM 40/30 DX SIC</i>	6	<i>2390150450</i>	
9	Bras intérieur	Interior arm	3	1	120B156130	
10	Bras extérieur	Exterior arm	(upper)	1	120B155890	
	<i>Bague</i>	<i>Ring</i>	<i>PM 40/30 DX SIC</i>	8	<i>2390150450</i>	
11	Bras intérieur	Interior arm	4	1	120B156160	
12	Vis	Screw	H M8X80/22 CL8.8 ZB	28	2301231750	
13	Axe	Pin		2	120C148920	
14	Axe	Pin		9	118D159270	
15	Axe	Pin		6	120D159320	
16	Axe	Pin		4	120C149210	
17	Axe	Pin		4	120D159350	
18	Axe	Pin		2	120D159360	
19	Axe de vérin	Cylinder axis		2	118D159340	
20	Anneau élastique	Rubber ring		22	2479001080	
21	Rondelle	Washer	Ø65/40 ep.4mm	24	116D168830	

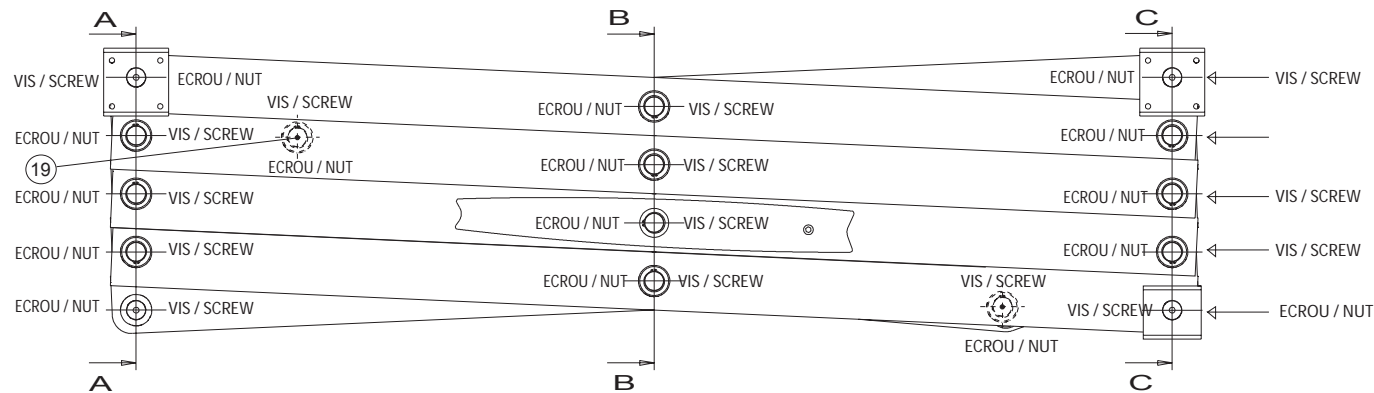
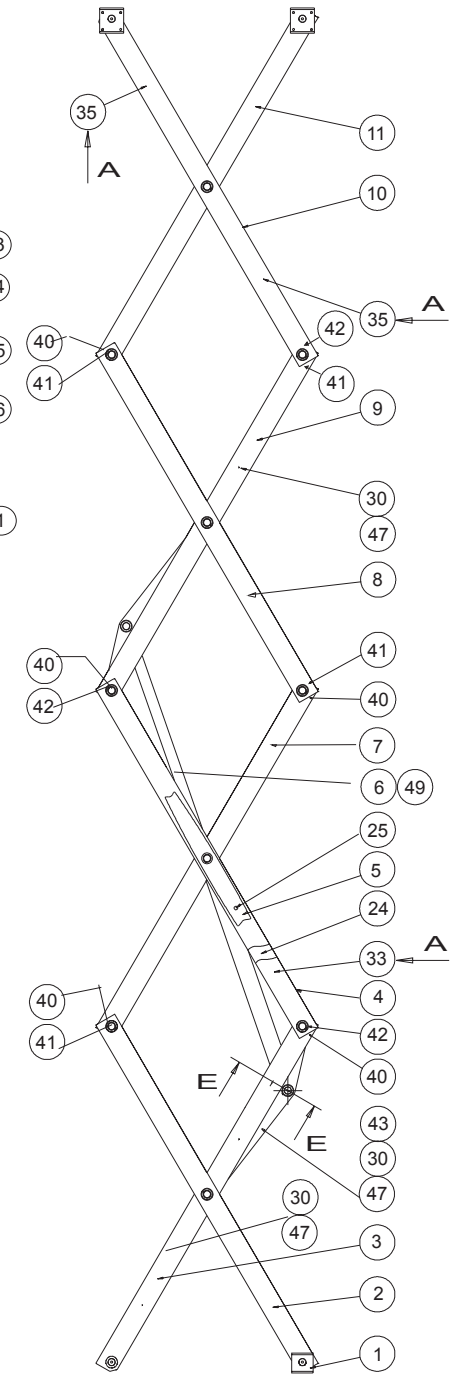
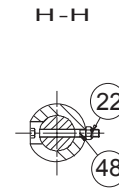
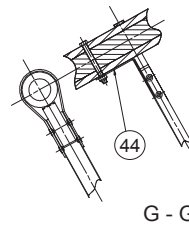
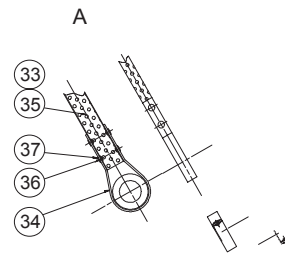
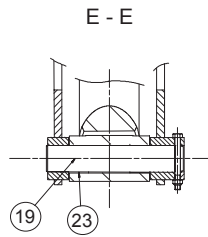
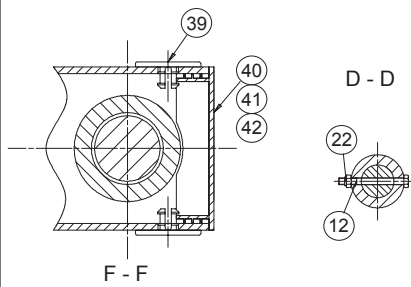
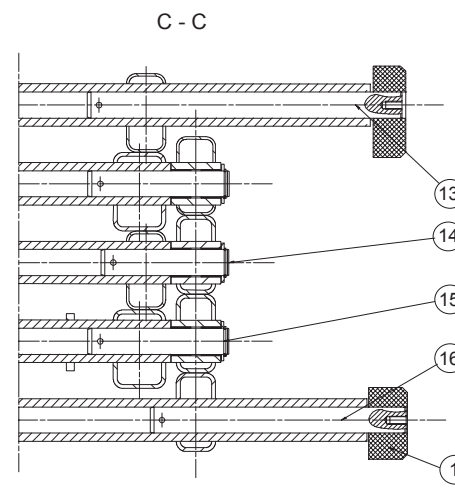
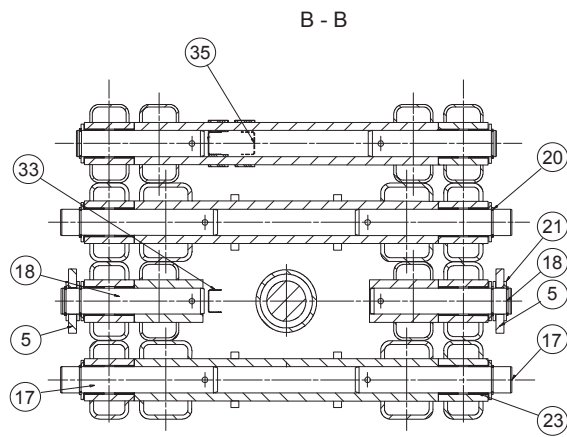
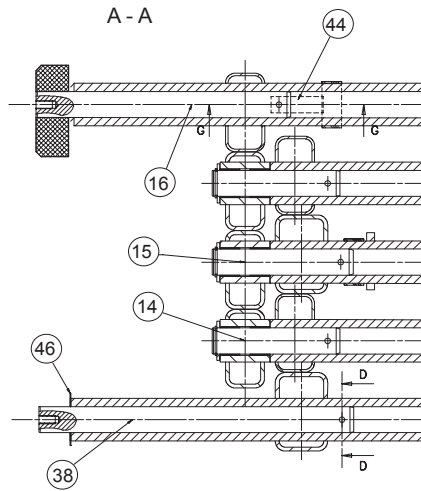

120P240240B

▲ Ensemble ciseaux
Scissor lift platform unit

Rep.	Désignation	Designation	Specification	Qty	Code	Up to / jusqu'à
22	Ecrou	Nut	M8 CL8ZB	30	2349221500	
25	Vis à oreilles	Wing screw	M8x30	1	2330003330	
30	Collier	Collar	Ø18	9	2389001560	
33	Goulotte	Trunking	2,04m	1	118C151480	
34	Sangle batterie	Battery strap		6	118C151470	
35	Goulotte	Trunking	0,96m	2	118C151490	
36	Rivet	Rivet	TAPD	24	2421808290	
38	Axe	Pin		2	120C152910	
39	Butée	Stop		24	118D160390	
40	Embout	End fitting		10	2420506060	
41	Embout	End fitting		8	2420506050	
42	Embout	End fitting		6	2420506040	
43	Vis	Screw	H M5 25/25 CL 8,8 ZB	1	2301231330	
44	Equerre de sécurité	Safety support		1	118D161610	
46	Rondelle de réglage	Adjustment washer		1	118D161960	
48	Vis	Screw	CHC M8x65/22 8.8	2	2330002170	
49	Capteur de pression	Pressure sensor		1	2421620600	
80	Mousse	Foam	80x60x30	4	2421303650	

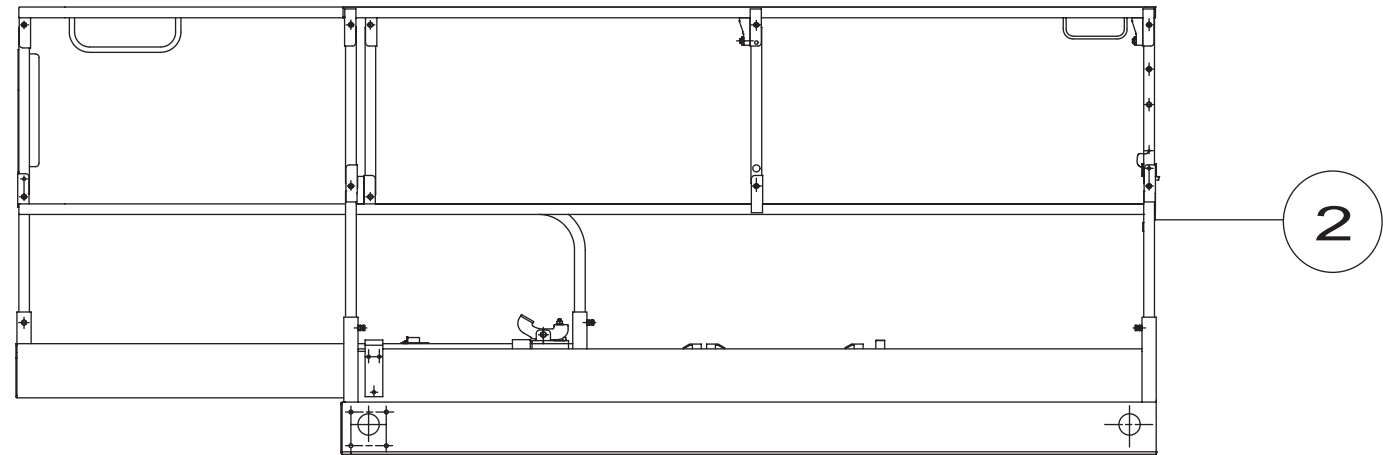
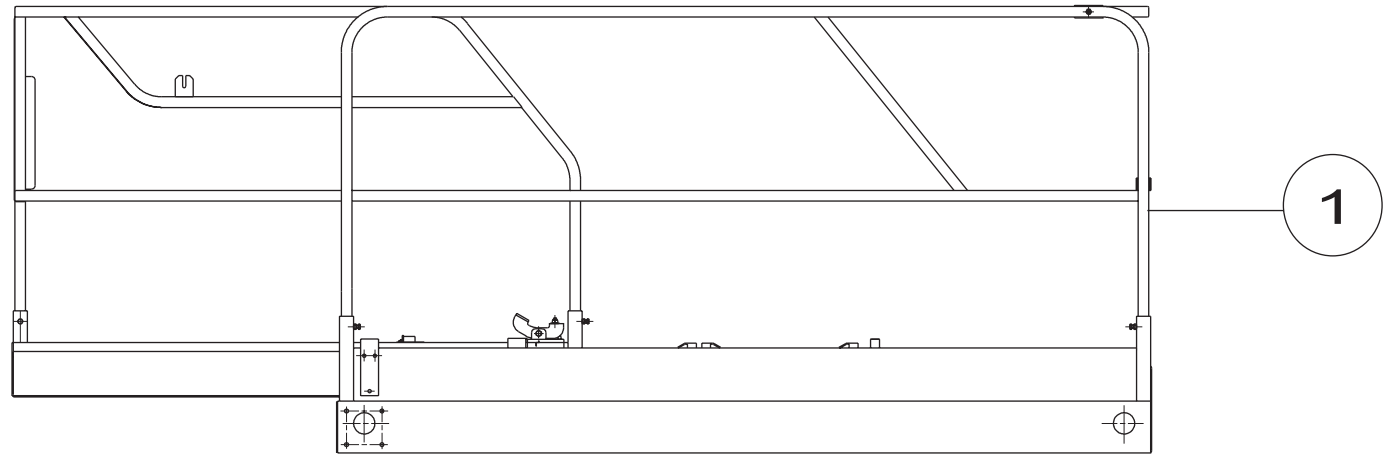

D16078 b

▲ **Plate-forme**
Platform



Rep.	Désignation	Designation	Specification	Up to / jusqu'à
1	Plate-forme	Platform		
2	Coffret nacelle	Platform control box		

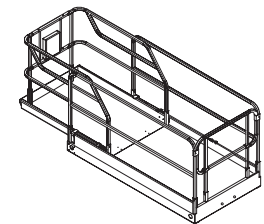
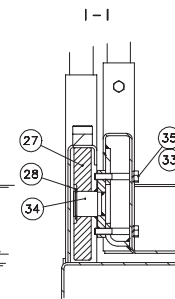
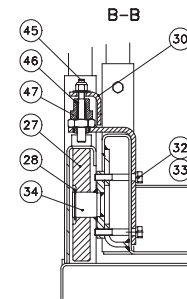
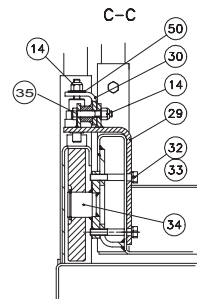
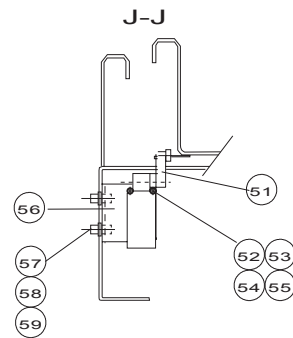
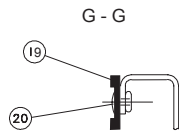
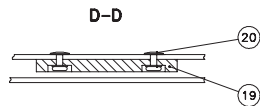
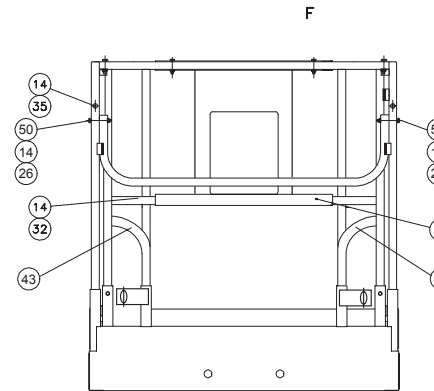
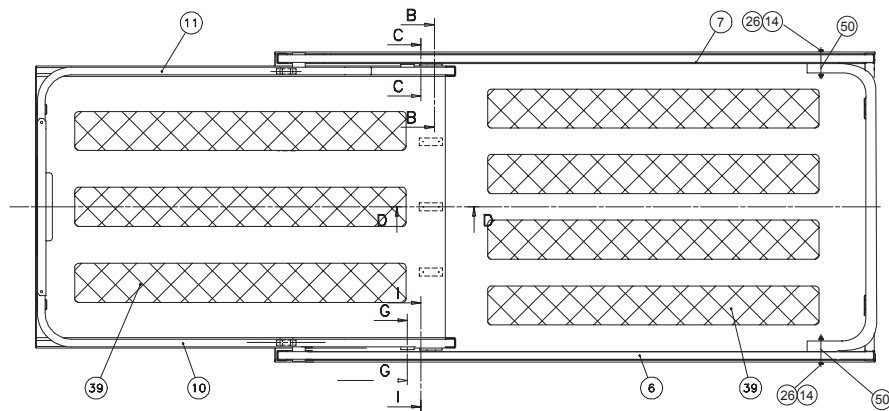
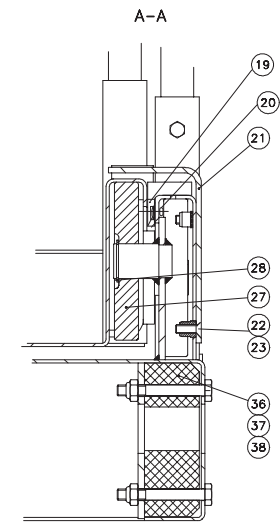
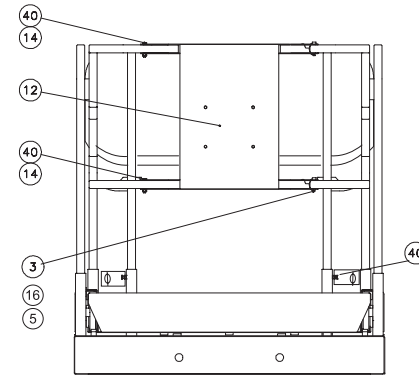
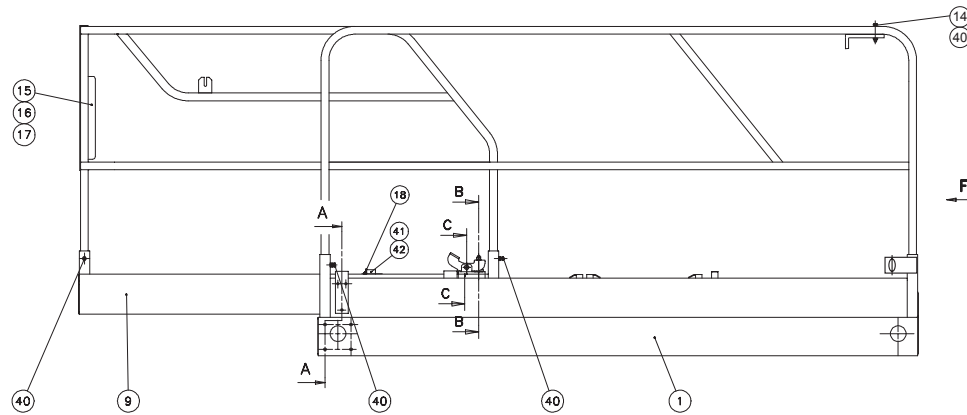

121P239450 B

**▲ Plate-forme
Platform**

**◀ C1
1/3 ▶**

Rep.	Désignation	Designation	Specification	Qty	Code	Up to / jusqu'à
1	Plate-forme	Platform	1,2m	1	121P239460	
3	Goupille	Pin		2	2352312430	
5	Chaînette	Small chain	14,5x5,2 FIL D.2,2	2	2425631220	
6	Garde corps GA	Left guardrail		1	118B170140	
7	Garde corps DR	Right guardrail		1	118B170150	
8	Barre de liaison	Connecting bar		1	118B170060	
9	Extension plancher	Flooring extension		1	121P239470	
10	Garde corps	Guardrail		1	118B155780	
11	Garde corps	Guardrail		1	118B155790	
12	Garde corps interméd.	Intermediate guardrail		1	119B155800	
14	Ecrou	Nut	M8 CL8ZB	12	2349221500	
15	Boîte à documents	Document box	MANUAL-PAK	1	2420209920	
16	Rivet	Rivet	M5 X 16 Zn	6	2421803190	
17	Rondelle plate	Flat washer	M5 U ZB	4	2351112040	
18	Ecrou	Nut	M6 CL8ZB	2	2349221490	
19	Plaque d'appui	Bearing plate		7	118D158190	
20	Rivet	Rivet	TAPD Ø4 LG.10,5	14	2421809000	
21	Equerre de sécurité	Safety support		2	118C148840	
22	Vis	Screw	H M8X25/25 CL8.8 ZB	6	2331231430	
24	Galon non feutré	Braid (not felt)	DRAFTEX	1	2420701180	
25	Embout	End fitting		4	2420505880	
26	Vis	Screw	H M8 75/22 cl 8.8 ZB	4	2301231740	
27	Galet	Roller		4	118D159200	
28	Circlips	Circlips	2000 Ø32 E	4	2472001290	
29	Support	Holder		1	118C152980	
30	Pédale	Pedal		1	118C152970	

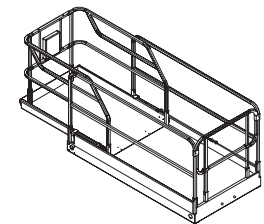
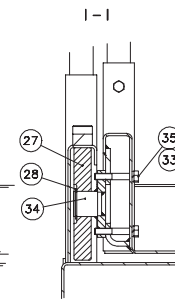
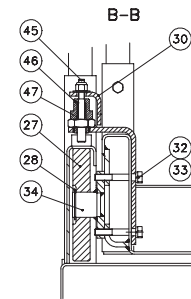
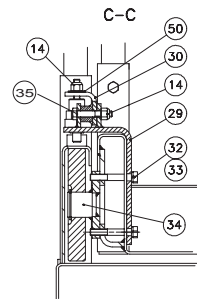
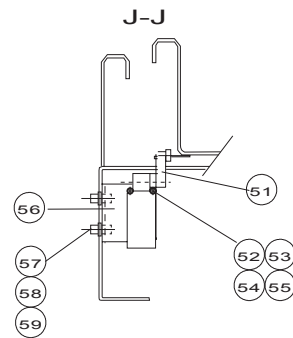
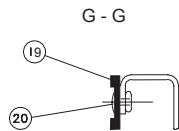
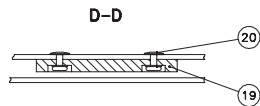
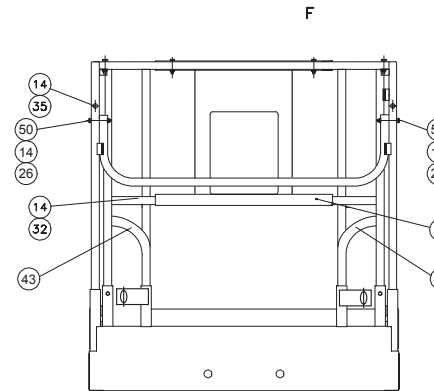
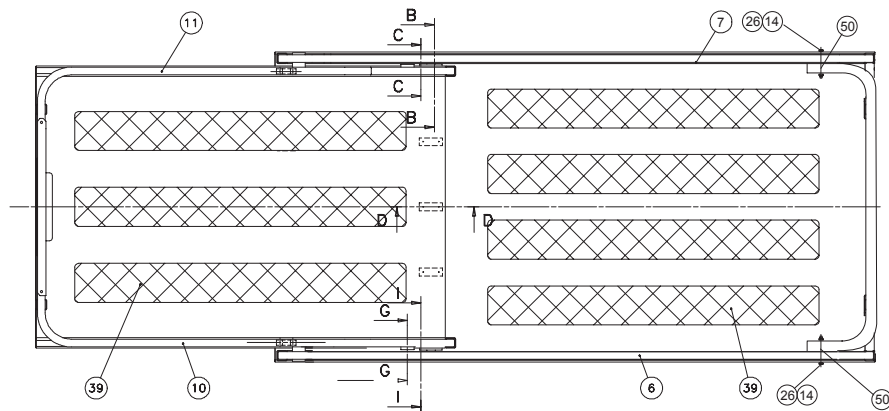
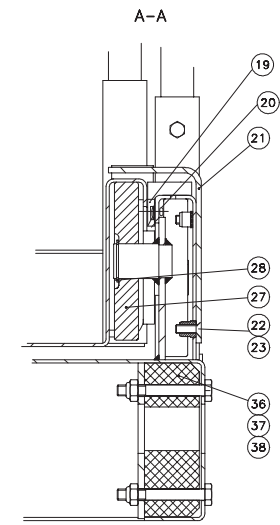
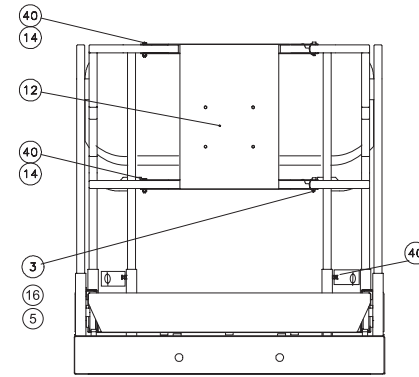
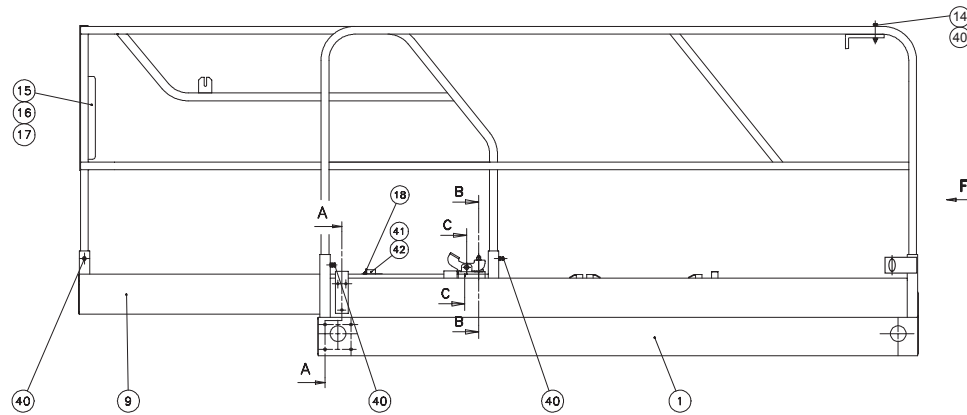

121P239450 B

▲ **Plate-forme**
Platform

◀ **C1**
2/3 ▶

Rep.	Désignation	Designation	Specification	Qty	Code	Up to / jusqu'à
32	Vis	Screw	HM8x55/22 CL.8.8 ZB	6	2301231700	
33	Rondelle	Washer	GROWER W 8	14	2351201070	
34	Axe galet extension	Extension roller pin		2	118C148890	
35	Vis	Screw	H M8X50/22 CL8.8 ZB	7	2301231690	
36	Patin	Pad		4	118D159210	
37	Vis	Screw	H M10X80/26 CL8.8 ZB	8	2301231860	
38	Ecrou	Nut	M10 CL8ZB	8	2349221510	
39	Adhésif anti-dérapant	Non-slip adhesive tape		7	118C159140	
40	Vis	Screw	H M8X50/50 CL8.8 ZB	12	2331231490	
41	Collier	Collar	215 PP	1	2389003260	
42	Vis	Screw	CHC M6X40/24 8.8	2	2308231530	
43	Tube	Tube		1	124C174280	
44	Tube	Tube		1	124C174290	
45	Axe verrou	Locking pin		1	118D160380	
46	Loquet	Latch		1	118C152960	
47	Ressort	Spring		1	2421808570	
50	Rondelle plate	Flat washer	L8 U ZB	5	2351113070	
51	Interrupteur de position	Position switch		1	2440901490	
52	Vis	Screw	CHC M4x35/20 CL8.8 ZB	2	2308231220	
53	Rondelle plate	Flat washer	M4 ZB	2	2351112030	
54	Rondelle à dents	Tooth lock washer	DEC 4 ZB	2	2351301050	
55	Ecrou	Nut	HM4 CL.8 ZB	2	2341221030	
56	Support contacteur	Contact switch holder		1	126P246450	
57	Vis	Screw	HM6x20/20 CL.8.8 ZB	2	2331231330	
58	Rondelle plate	Flat washer	M6 ZB	2	2351112050	
59	Rondelle à dents	Tooth lock washer	DEC 6 ZB	2	2351301070	

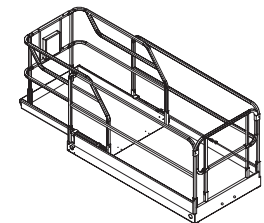
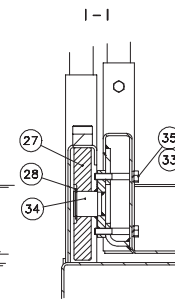
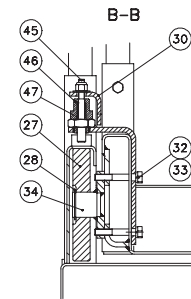
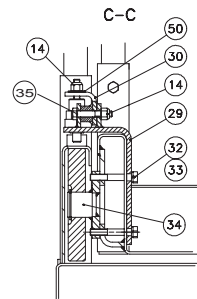
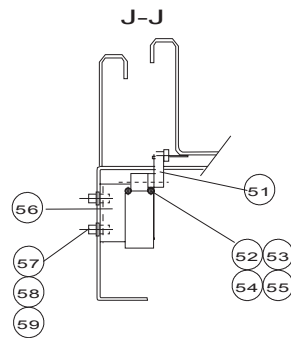
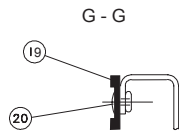
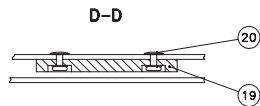
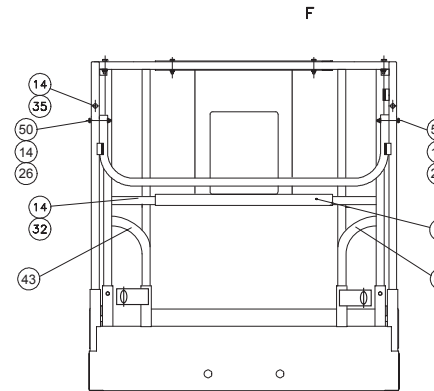
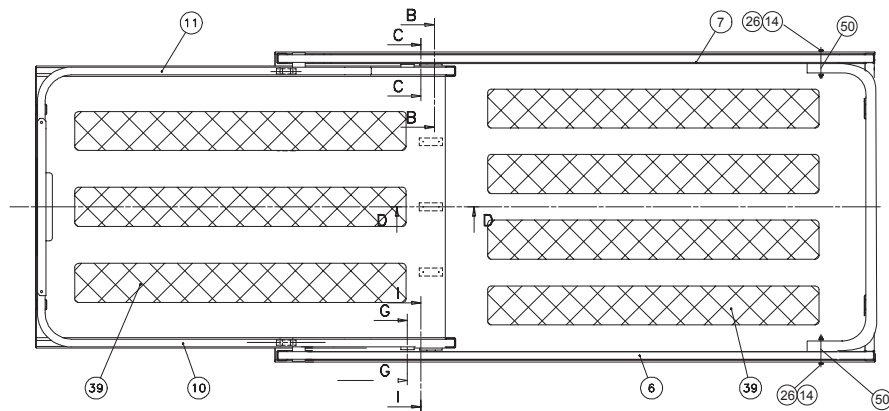
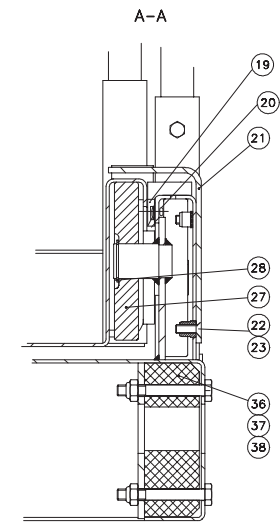
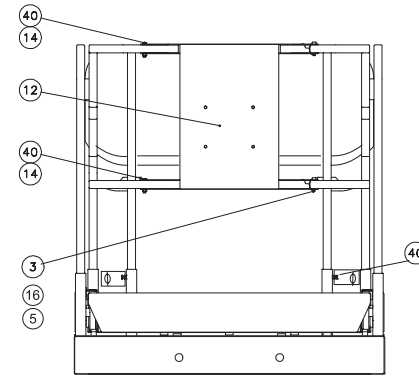
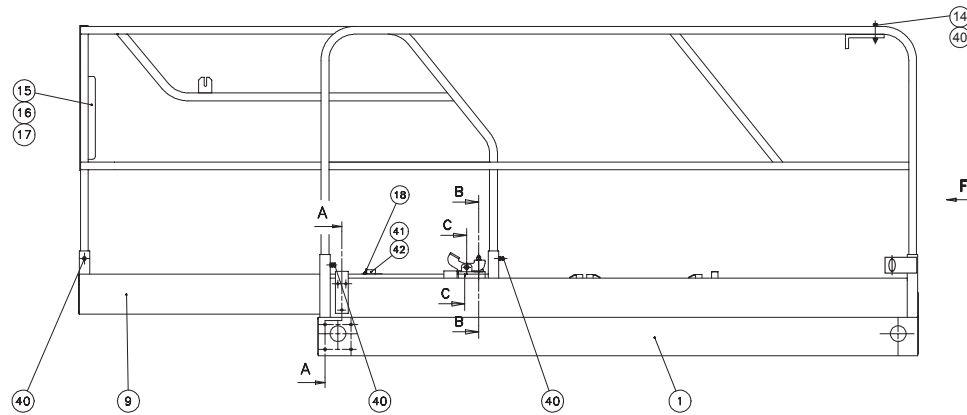

121P239450 B

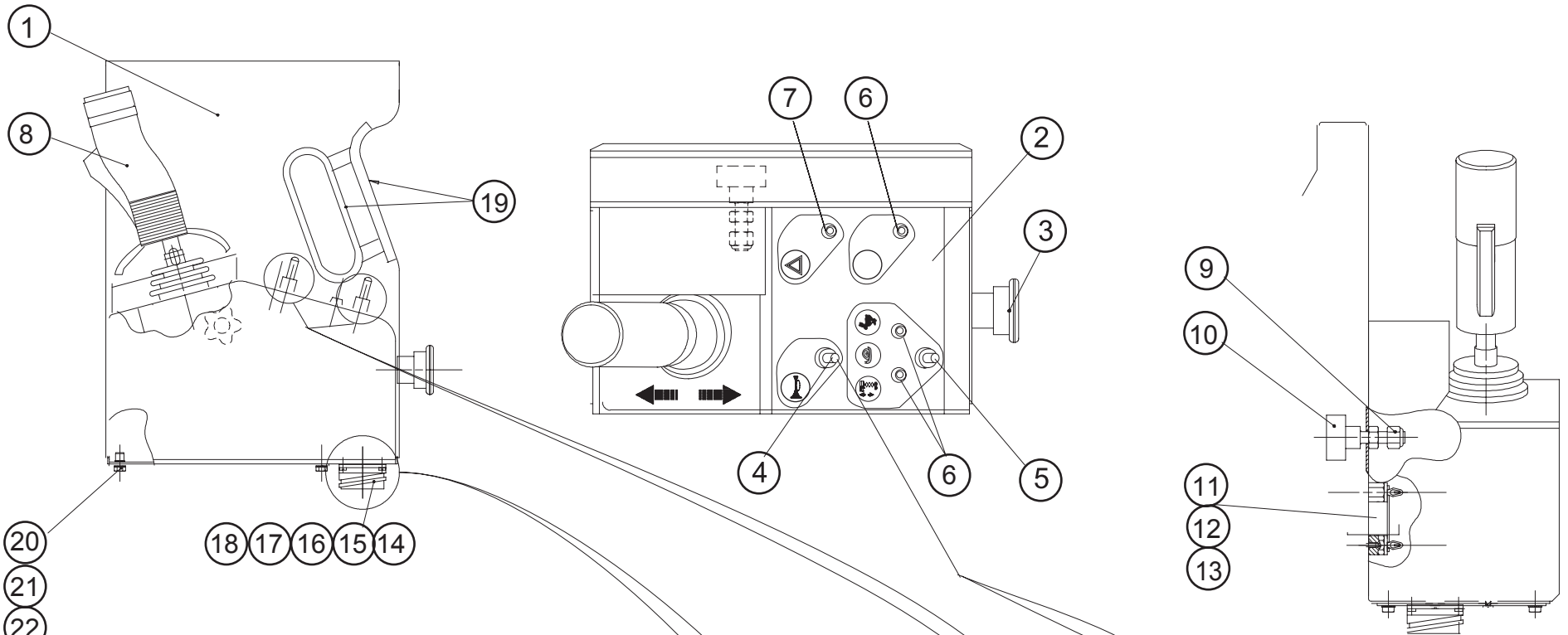

montage du boîtier sur garde corps fixe
 fitting the control panel on a fixed guardrail

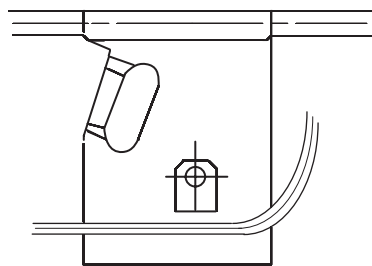

rondelle plastique
 plastic washer

joint / seal

ecrou / nut

axe d'articulation
 hinge pin

ecrou / nut

coffret électrique
 electric box

▲ **Coffret nacelle**
Platform control box

◀ **C2**
1/2 ▶

Rep.	Désignation	Designation	Specification	Qty	Code	Up to / jusqu'à
1	Boîtier de commande	Control box		1	118A149380	
	<i>Pupitre nacelle</i>	« Platform panel » label		1	3078151230	
2	Pupitre nacelle	« Platform panel » label		1	3078151230	
3	Corps complet	Contact block		1	2440314420	
	<i>Contact auxiliaire</i>	<i>Auxiliary contact</i>		2	2440318790	
	<i>Bouton coup de poing</i>	<i>Mushroom-headed button</i>		1	2442009620	
3	Bouton coup de poing	Mushroom-headed button		1	2442009770	
4	Inter. unipolaire levier	Single-pole toggle switch		1	2440901640	
5	Interrupteur	Switch		1	2440901630	
6	Voyant vert	Green indicator light	12-24V Ø16	3	2442202040	
7	Voyant rouge	Red light indicator		1	2442202030	
8	Manipulateur 1 axe	Single-axis controller		1	2441305220	
9	Volant à lobes	Lobe wheel		1	2421608690	
10	Ecrou	Nut	M8 CL8ZB	1	2349221500	
11	Carte Serial	Serial board		1	2440316580	
12	Support	Holder		4	2421906430	
13	Vis	Screw	Ø3.5CL lg 9.5	4	2330002640	
14	Faisceau	Bundle		1	118B169610	
14	Embase	Base	16x1	1	2440502970	
15	Joint	Seal		1	118D162110	
16	Vis	Screw	C M3X12 CL4.8ZB	4	2306311030	
17	Rondelle à dents	Tooth lock washer	DE 3ZB	4	2351301030	
18	Ecrou	Nut	H M3 CL 8 ZB	4	2341221010	
19	Galon non feutré	Braid (not felt)	DRAFTEX	400	2420701180	
20	Tôle	Plate		1	118C158630	
21	Rondelle à dents	Tooth lock washer	DE 4ZB	4	2351301050	

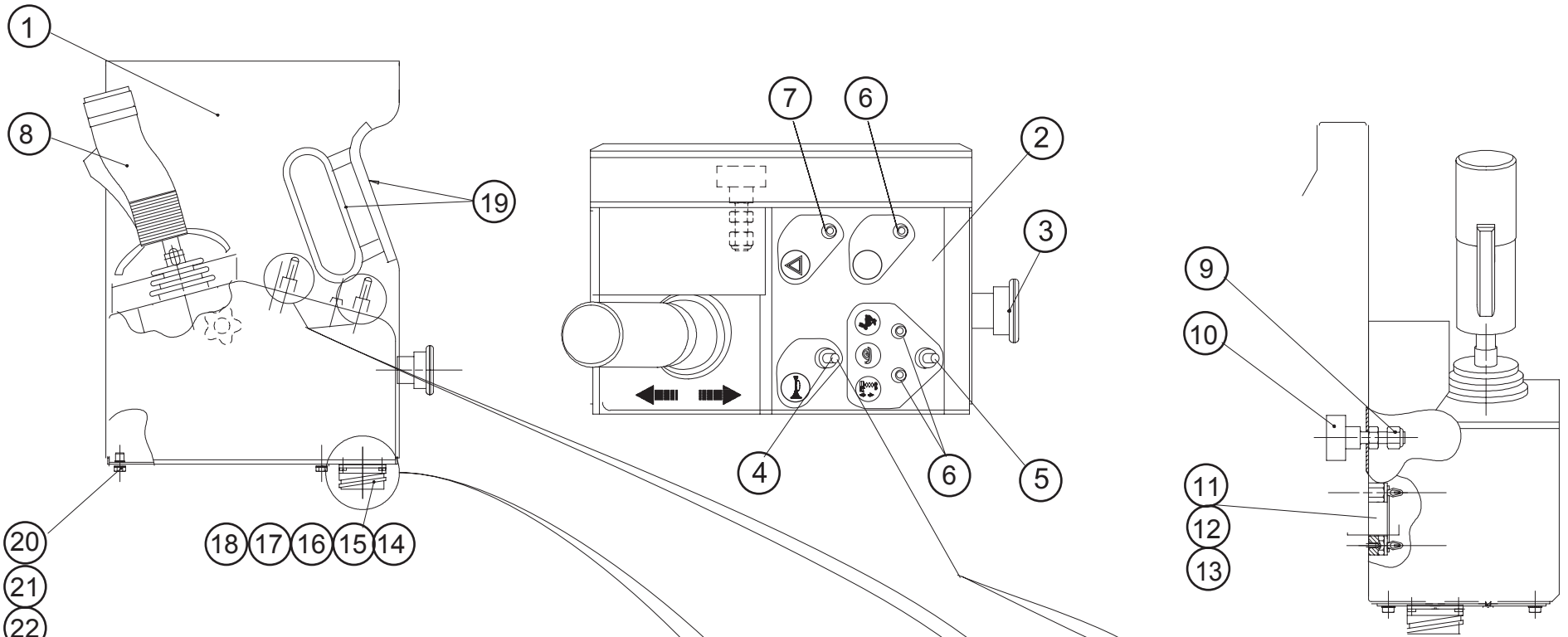

montage du boîtier sur garde corps fixe
 fitting the control panel on a fixed guardrail

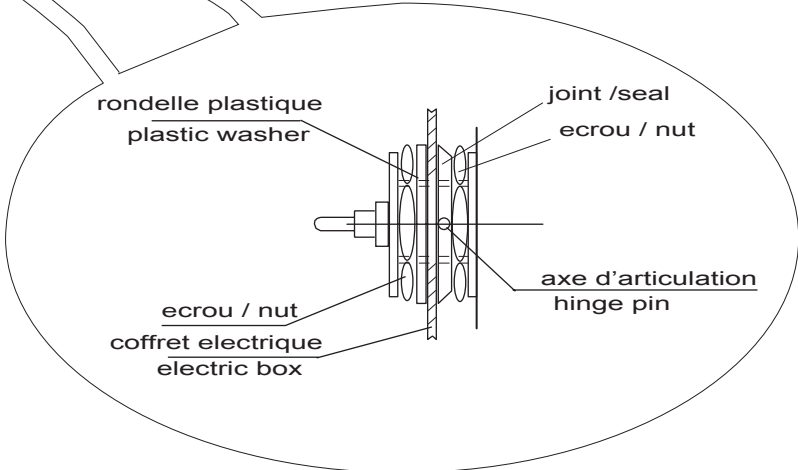
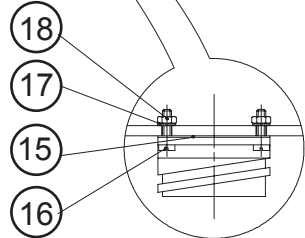
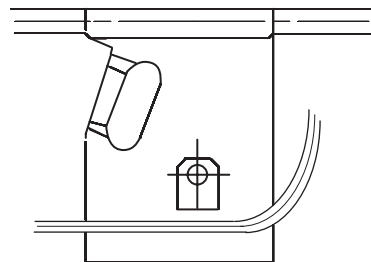

**▲ Coffret nacelle
Platform control box**

Rep.	Désignation	Designation	Specification	Qty	Code	Up to / jusqu'à
22	Vis	Screw	HM 4X10/10 8.8	4	2331231100	

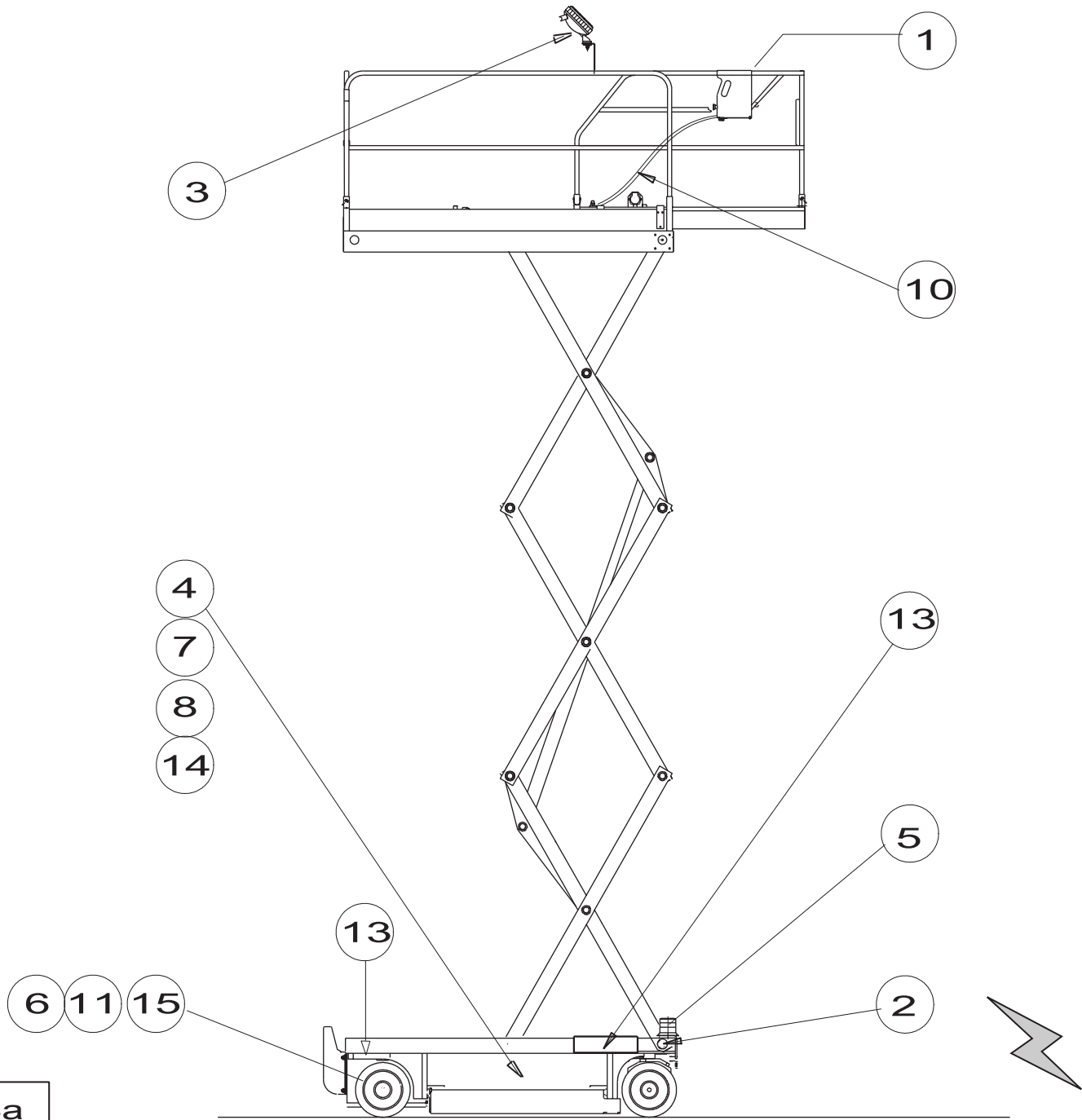

D16528a

▲ **Option**
Option



Rep.	Désignation	Designation	Specification	Up to / jusqu'à
1	Platef garde-corps rabat	Platform with foldable guard rail		
2	Aliment. sur plateforme	Platform supply	220V	
2	Aliment. sur plateforme	Platform supply	220V Eur.	
2	Aliment. sur plateforme	Platform supply	115V Eur.	
3	Phare de travail	Work headlight		
4	Chargeur	Charger	110V	
5	Feu à éclat	Flashing light		
6	Remplissage centralisé	Centralised filling		
7	Arrêt d'urgence	Emergency stop		
8	Disjoncteur différentiel	Differential circuit breaker	220V	
10	Rallonge poste conduite	Operating station extension		
11	Batterie sèche	Dry battery		
12	Huile biologique	Organic oil		
13	LIXXBAIL ...	LIXXBAIL label		
14	Chargeur bi-tension	Bi-voltage charger		
15	Batteries étanches	Sealed batteries		

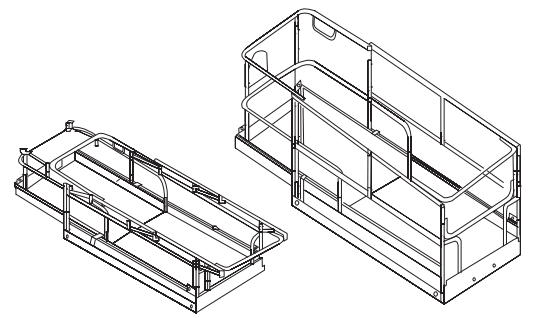
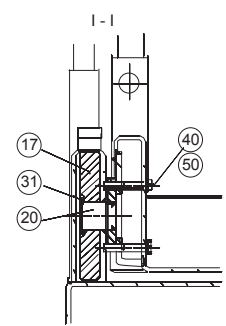
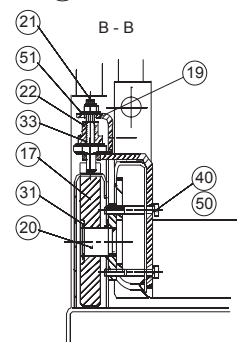
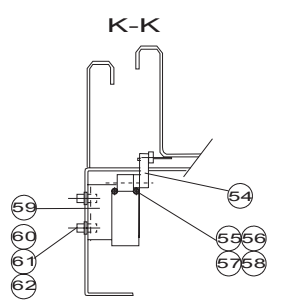
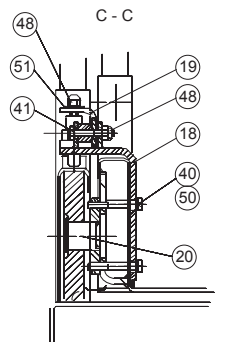
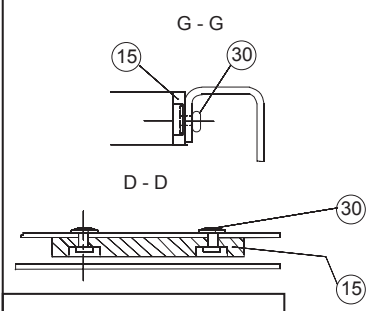
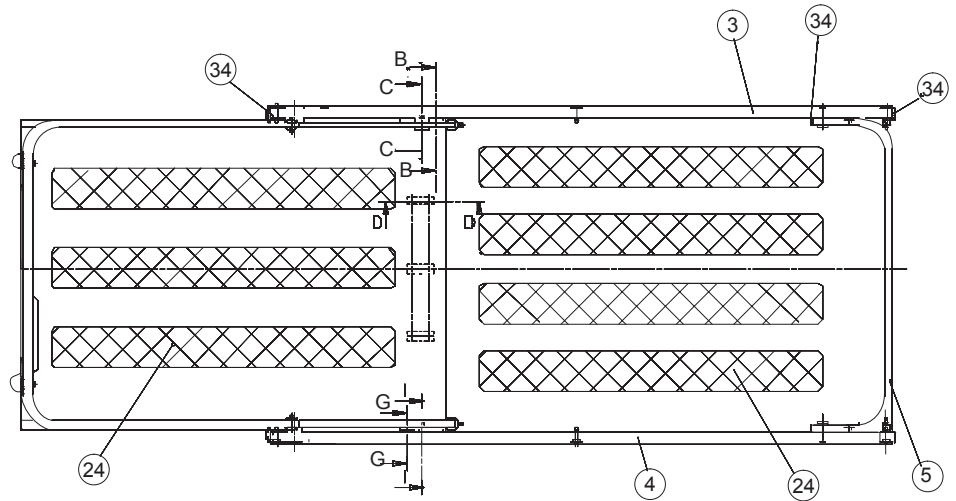
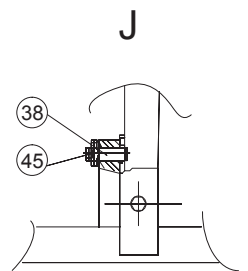
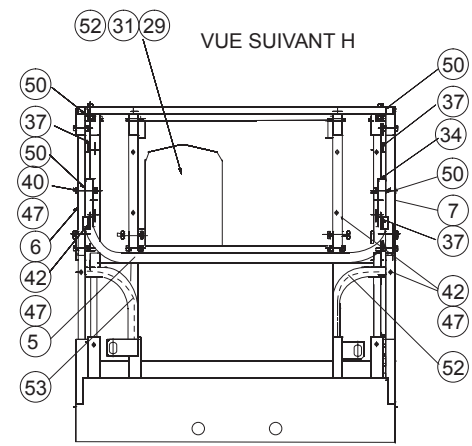
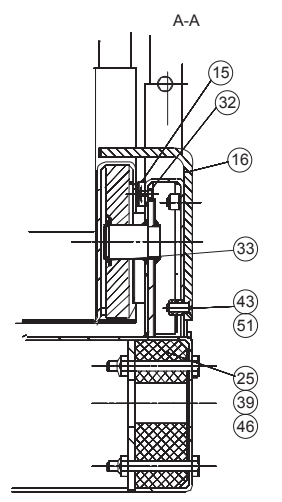
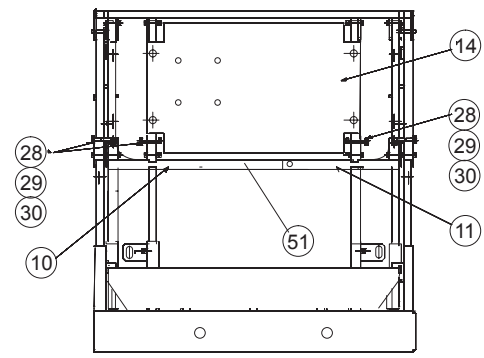
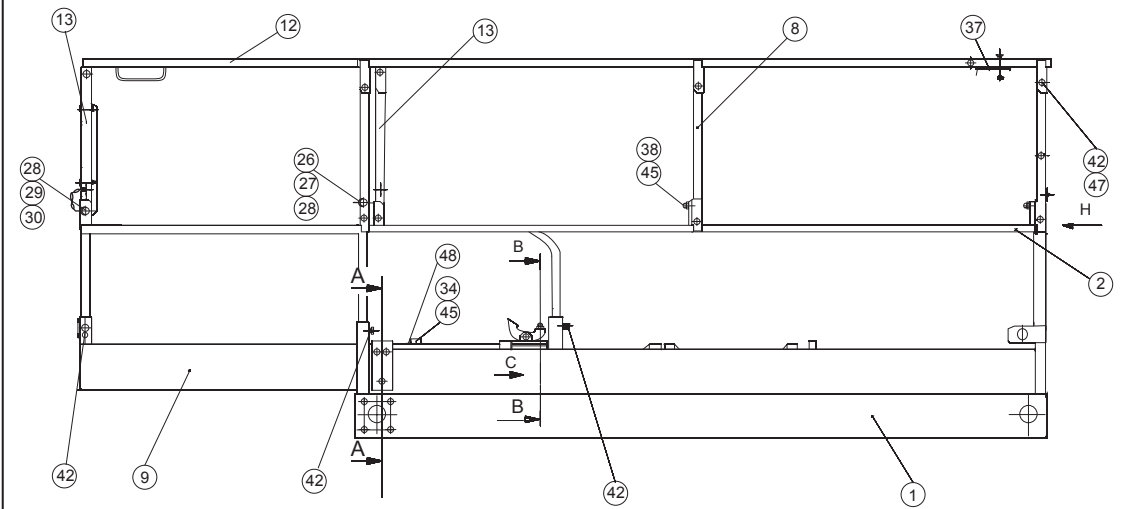

121P239580A

▲ Platef garde-corps rabat
Platform with foldable guard rail

◀ **D1** ▶
1/3

Rep.	Désignation	Designation	Specification	Qty	Code	Up to / jusqu'à
1	Plateforme	Platform	1,2m	1	121P239460	
2	Garde corps plateforme	Platform safety barrier		2	124B169300	
3	Lisse	Rail		1	124B169230	
4	Lisse	Rail		1	124B169240	
5	Barre de liaison	Connecting bar		2	118B170060	
6	Biellette gauche	Left link		1	124C173460	
7	Biellette droite	Right link		1	124C173470	
8	Biellette	Link rod		4	124C173480	
9	Extension plancher	Flooring extension		1	121P239470	
10	Lisse	Rail		1	124B169270	
11	Lisse	Rail		1	124B169260	
12	Lisse garde-corps	Barrier handrail	sup.	1	124B170080	
13	Biellette extension	Extension rod		4	124C173500	
14	Tôle entretoise	Spacer plate		1	124B170090	
15	Plaque d'appui	Bearing plate		6	118D158190	
16	Equerre de sécurité	Safety support		2	118C148840	
17	Galet	Roller		4	118D159200	
18	Support	Holder		1	118C152980	
19	Pédale	Pedal		1	118C152970	
20	Axe galet extension	Extension roller pin		2	118C148890	
21	Axe verrou	Locking pin		1	118D160380	
22	Loquet	Latch		1	118C152960	
23	Patte de bridage	Flanging tab		1	118D160420	
24	Adhésif anti-dérapant	Non-slip adhesive tape		5	118C159140	
25	Patin	Pad		4	118D159210	
26	Goupille	Pin		4	2352312430	

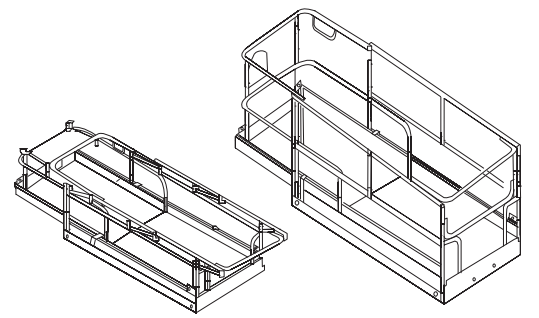
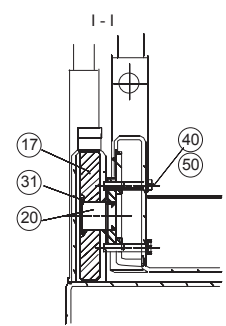
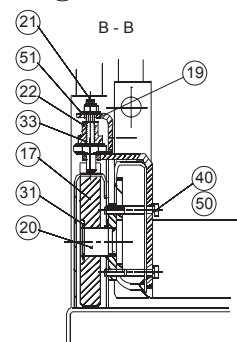
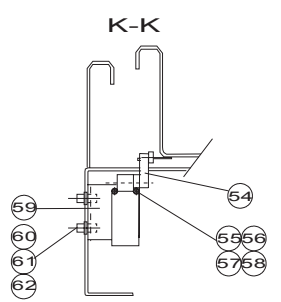
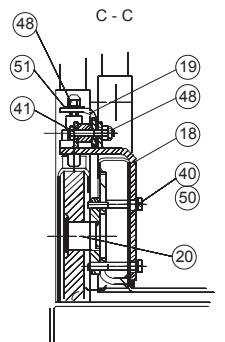
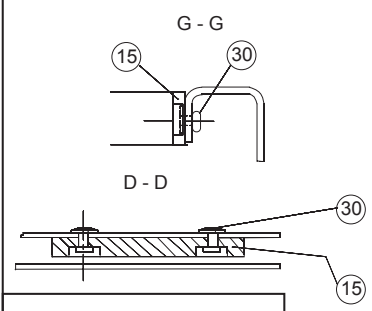
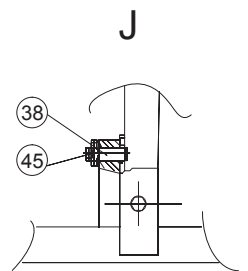
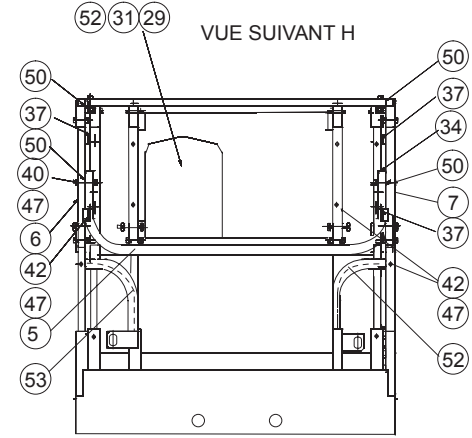
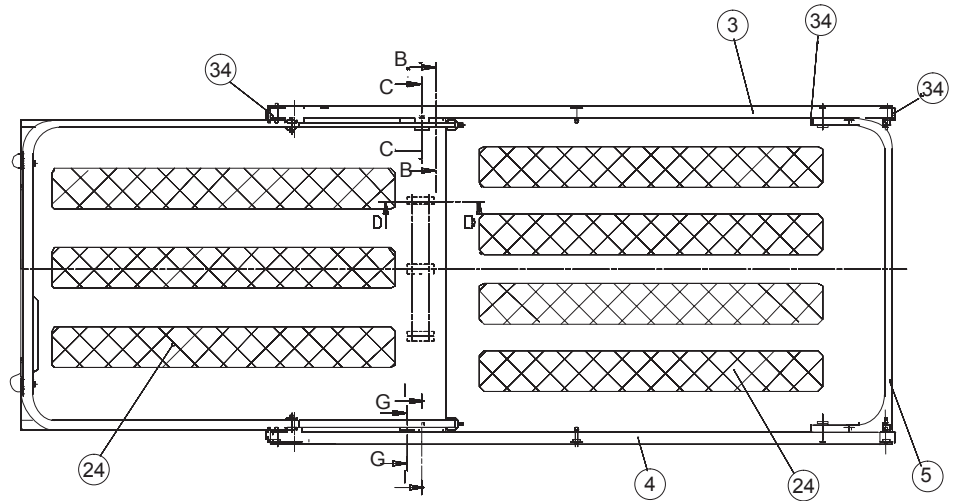
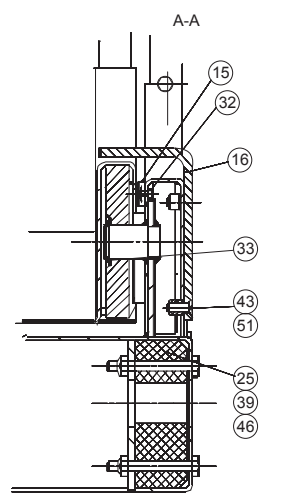
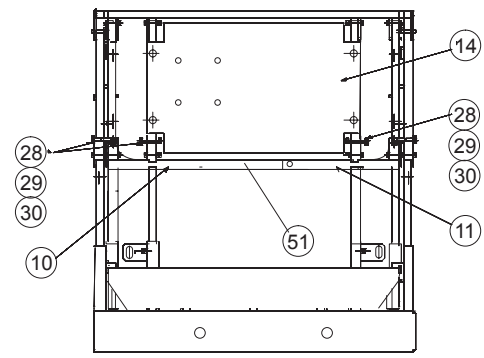
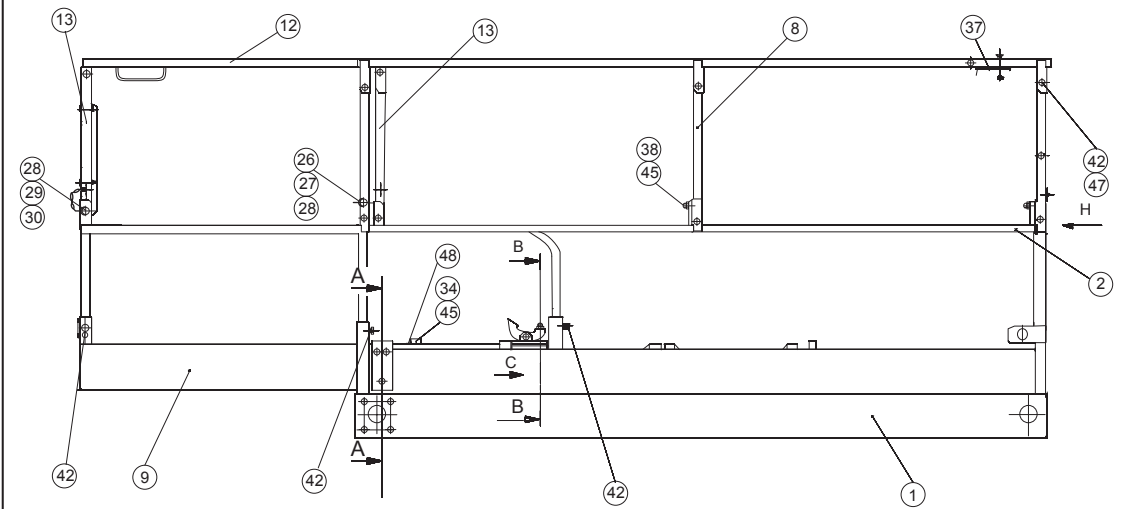

121P239580A

▲ **Platef garde-corps rabat**
Platform with foldable guard rail

Rep.	Désignation	Designation	Specification	Qty	Code	Up to / jusqu'à
27	Rivet	Rivet	M5 X 16 Zn	8	2421803190	
28	Chaînette	Small chain	14,5x5,2 FIL D.2,2	4	2425631220	
29	Boîte à documents	Document box		1	2420209920	
30	Rivet	Rivet	TAPD Ø4 LG.10,5	12	2421809000	
31	Circlips	Circlips	2000 Ø32 E	4	2472001290	
32	Embout	End fitting		10	2420505880	
33	Ressort	Spring		1	2421808570	
34	Collier	Collar	215 PP	1	2389003260	
35	Galon non feutré	Braid (not felt)	DRAFTEX	1	2420701180	
36	Vis	Screw	HC M12 35/35 cl 8.8 ZB	4	2316131230	
37	Vis	Screw	H M10X80/26 CL8.8 ZB	8	2301231860	
38	Vis	Screw	H M8 75/22 cl 8.8 ZB	4	2301231740	
39	Vis	Screw	H M8X55/22 CL8.8 ZB	4	2301231700	
40	Vis	Screw	H M8X50/50 CL8.8 ZB	39	2331231490	
41	Vis	Screw	FHC/90 M8x20/20 C8.8	6	2330002290	
42	Vis	Screw	CHC M6X40/24 8.8	2	2308231530	
43	Ecrou	Nut	HM M12 CL 8 ZB	4	2341222050	
44	Ecrou	Nut	M10 CL8ZB	8	2349221510	
45	Ecrou	Nut	M8 CL8ZB	27	2349221500	
46	Ecrou	Nut	M6 CL8ZB	2	2349221490	
47	Rondelle	Washer	GROWER W 8	8	2351201070	
48	Rondelle plate	Flat washer	L8 U ZB	7	2351113070	
49	Rondelle à dents	Tooth lock washer	DEF 8ZB	6	2351304220	
50	Rondelle plate	Flat washer	M5 U ZB	4	2351112040	
51	Entretoise	Brace	INF.	1	118C176400	
52	Tube	Tube		1	124C174290	

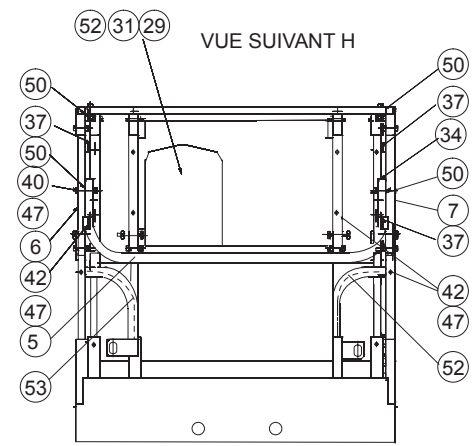
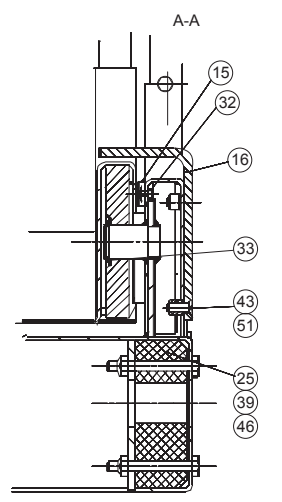
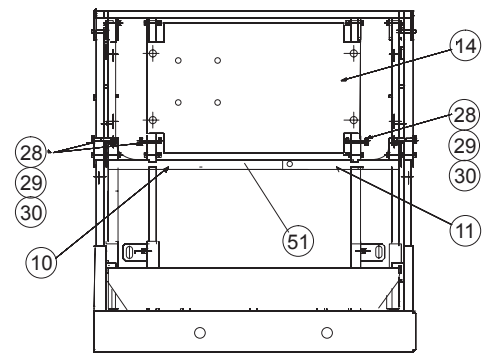
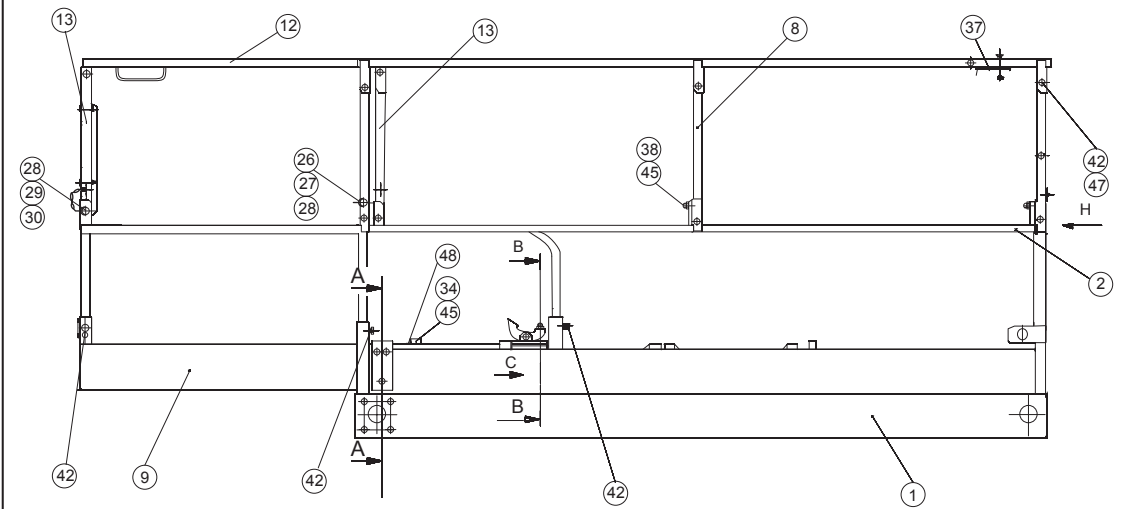

VUE SUIVANT H

J

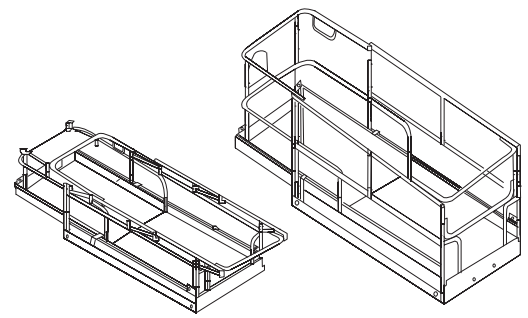
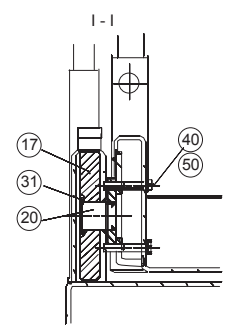
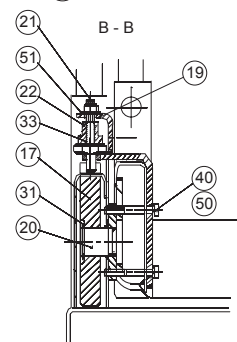
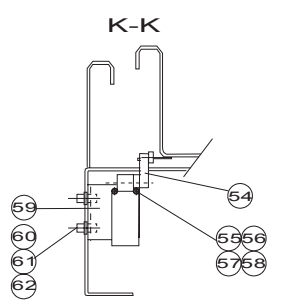
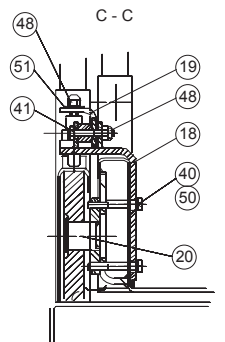
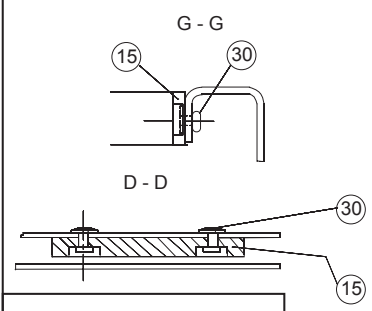
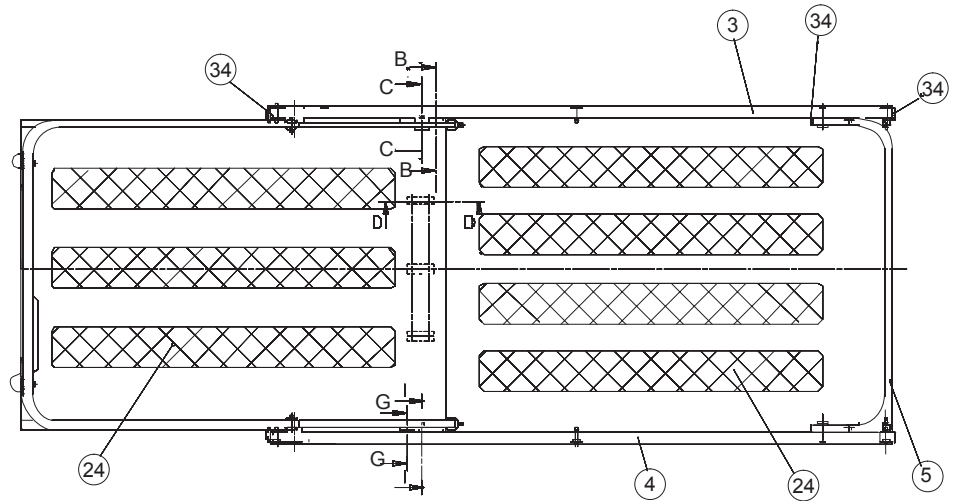
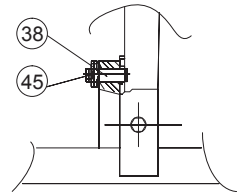

121P239580A

▲ **Platef garde-corps rabat**
Platform with foldable guard rail

Rep.	Désignation	Designation	Specification	Qty	Code	Up to / jusqu'à
53	Tube	Tube		1	124C174280	
54	Interrupteur de position	Position switch		1	2440901490	
55	Vis	Screw	CHC M4x35/20 CL8.8 ZB	2	2308231220	
56	Rondelle plate	Flat washer	M4 U ZB	2	2351112030	
57	Rondelle à dents	Tooth lock washer	DEC 4 ZB	2	2351301050	
58	Ecrou	Nut	HM4 CL.8 ZB	2	2341221030	
59	Support contacteur	Contact switch holder	1	1	126P246450	
60	Vis	Screw	HM6x20/20 CL.8.8 ZB	2	2331231330	
61	Rondelle plate	Flat washer	M6 ZB	2	2351112050	
62	Rondelle à dents	Tooth lock washer	DEC 6 ZB	2	2351301070	

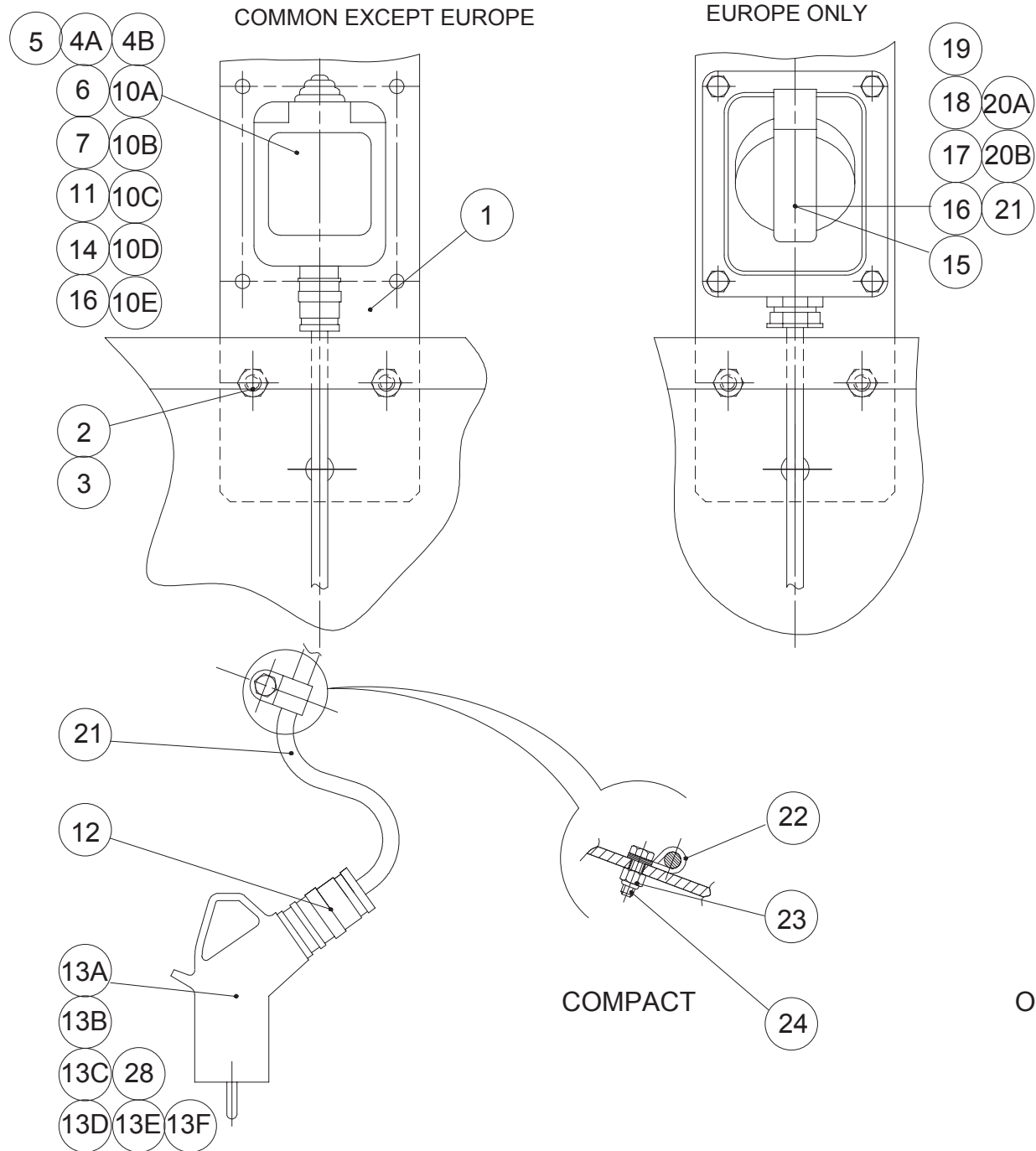

B 17024a

▲ Aliment. sur plateforme
Platform supply

220 V

◀ D2
1/4 ▶

Rep.	Désignation	Designation	Specification	Qty	Code	Up to / jusqu'à
1	Support	Holder		1	118C150650	
2	Rondelle à dents	Tooth lock washer	DE 8ZB	3	2351301090	
3	Vis	Screw	H M8X20/20 CL8.8 ZB	3	2331231420	
4	Boîtier	Box		1	2440203650	FR GB D CH
4	Boîtier vide étanche	Sealed empty box		1	2440203790	USA CANADA
5	Vis	Screw	HM 4X20/20 8.8	2	2331231120	
6	Rondelle à dents	Tooth lock washer	DE 4ZB	2	2351301050	
7	Ecrou	Nut	H M4 CL 8 ZB	2	2341221030	
10	Prise	Socket	2P+T-10/16A	1	2441605540	FR
10	Prise	Socket	2P+T-13A	1	2441605070	GB
10	Prise	Socket	2P+T-16A	1	2441605060	D
10	Prise	Socket	2P+T-15A-125V	2	2441605180	USA CAN
10	Prise	Socket	2P+T 10A	1	2441605930	CH
11	Contre-écrou	Lock nut	CE 16 In	1	2420302030	
12	Presse-étoupe	Packing box	13/9	1	2421607690	
13	Fiche	Plug	M 2P+T 10/16A	1	2440603970	FR
13	Fiche	Plug	13A	2	2440603750	GB
13	Fiche	Plug	M 2P+T 10/16A	1	2440603970	D
13	Fiche	Plug	2P+T	1	2440603760	USA CAN
14	Obturateur	Seal		1	2441500040	USA CAN CH
16	Presse-étoupe réd.	Reducing packing box	16/9	1	2441613020	
21	Câble	Cable	3G 2,5MM2	1	2440311750	
22	Collier	Collar	Ø8	1	2389001510	
23	Ecrou	Nut	M6 CL8ZB	1	2349221490	
24	Vis	Screw	HM 6X20/20 8.8	1	2331231330	
25	Vis	Screw	HM 6X16/16 8.8	1	2331231310	

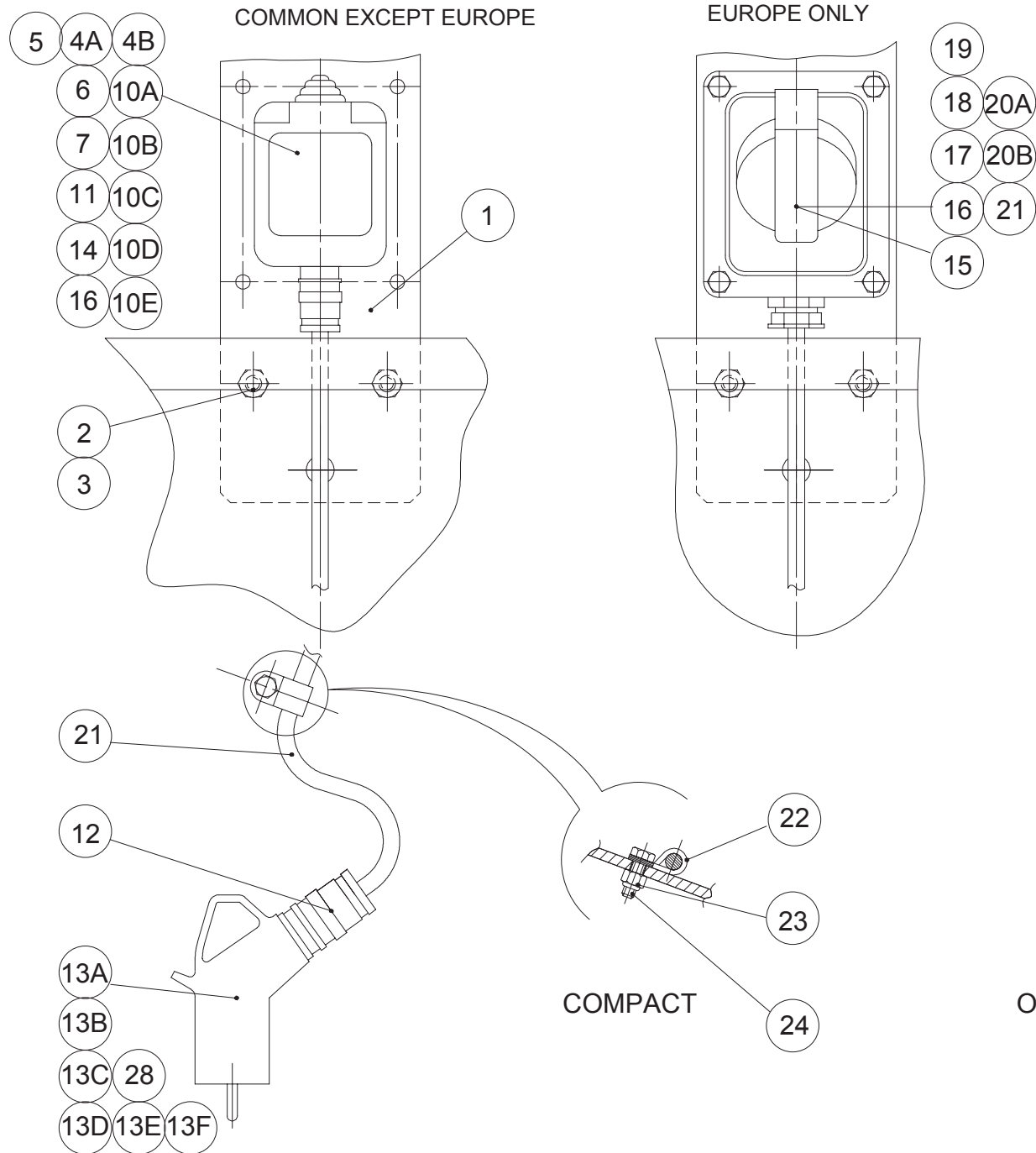

B 17024a

**▲ Aliment. sur plateforme
Platform supply**

220 V

**◀ D2
1/4 ▶**

Rep.	Désignation	Designation	Specification	Qty	Code	Up to / jusqu'à
99	Prise 230V	« 230 V socket » label		1	3078151370	FR GB D CH
99	Vis	Screw	Ø3.5CL lg 9.5	2	2330002640	USA CAN
99	Prise encastrable	Flush-fitting socket		1	2441605890	USA CAN
99	Prise élec/plateforme	Electric socket on platform label		1	3078148630	USA CAN
99	Prise 110V	« 110 V socket » label	Etiquette/Label	1	3078148900	USA CAN
99	Prise 230V	« 230 V socket » label		1	3078151360	FR GB D CH

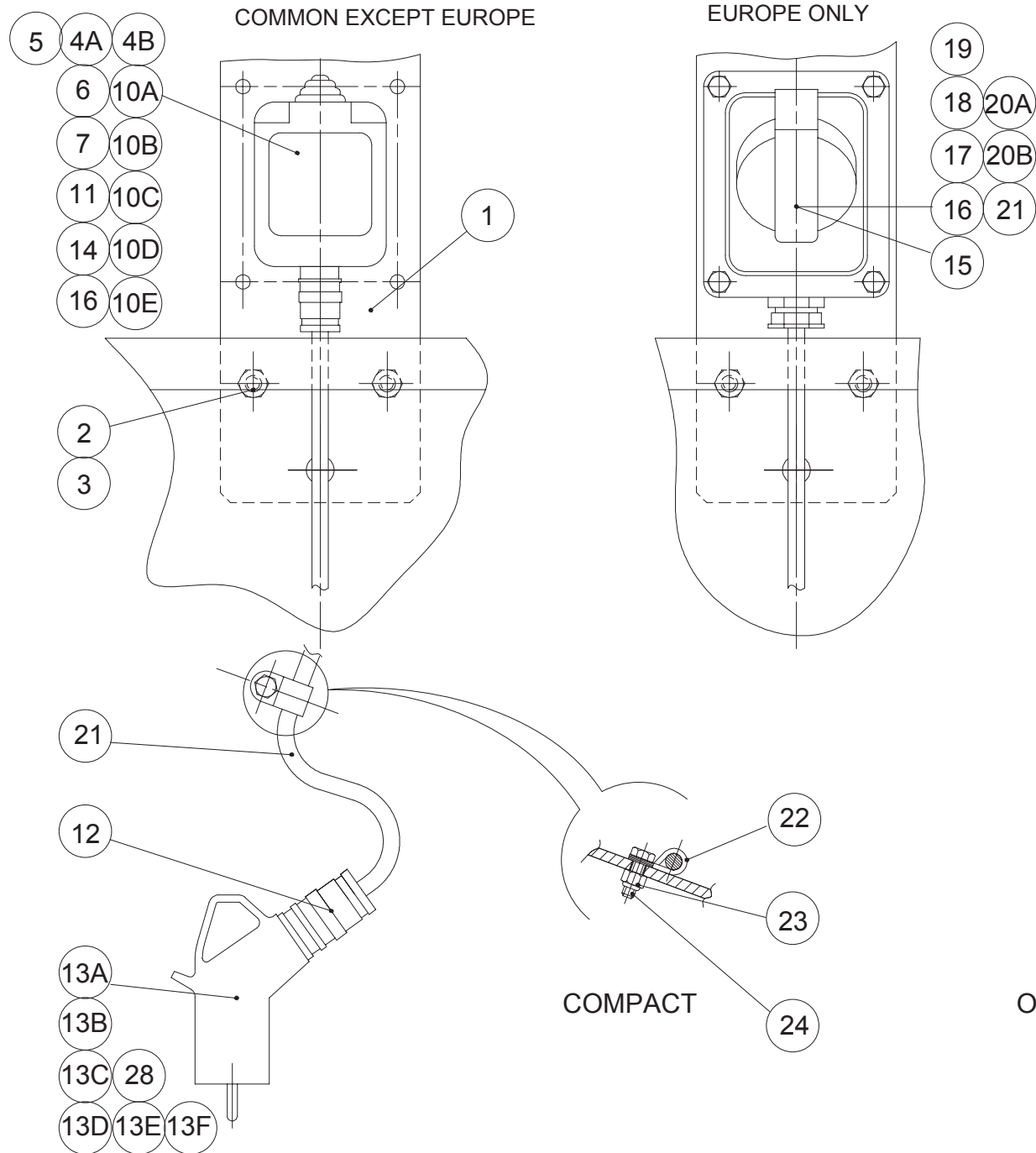

B 17024a

▲ Aliment. sur plateforme
Platform supply

EUR 220 V
220 V EUR

◀ D2
3/4 ▶

Rep.	Désignation	Designation	Specification	Qty	Code	Up to / jusqu'à
1	Support	Holder		1	118C150650	
2	Rondelle à dents	Tooth lock washer	DE 8ZB	3	2351301090	
3	Vis	Screw	H M8X20/20 CL8.8 ZB	3	2331231420	
13	Fiche	Plug	16A 2P+T 220V	1	2440603770	
15	Réducteur	Reducer		1	2421802260	
16	Presse-étoupe réd.		16/9	1	2441613020	
17	Vis	Screw	HM 6X20/20 8.8	4	2331231330	
18	Rondelle à dents	Tooth lock washer	DE 6ZB	4	2351301070	
19	Ecrou	Nut	H M6 CL 8 ZB	4	2341221050	
20	Socle	Base	PC 16A 2P+T 220	1	2441904280	
21	Câble	Cable	3G 2,5MM2	1	2440311750	
22	Collier	Collar	Ø8	1	2389001510	
23	Ecrou	Nut	M6 CL8ZB	1	2349221490	
24	Vis	Screw	HM 6X20/20 8.8	1	2331231330	
25	Contre-écrou	Lock nut		1	2440314130	
99	Prise 230V	« 230 V socket » label		1	3078151360	
99	Prise 230V	« 230 V socket » label		1	3078151370	

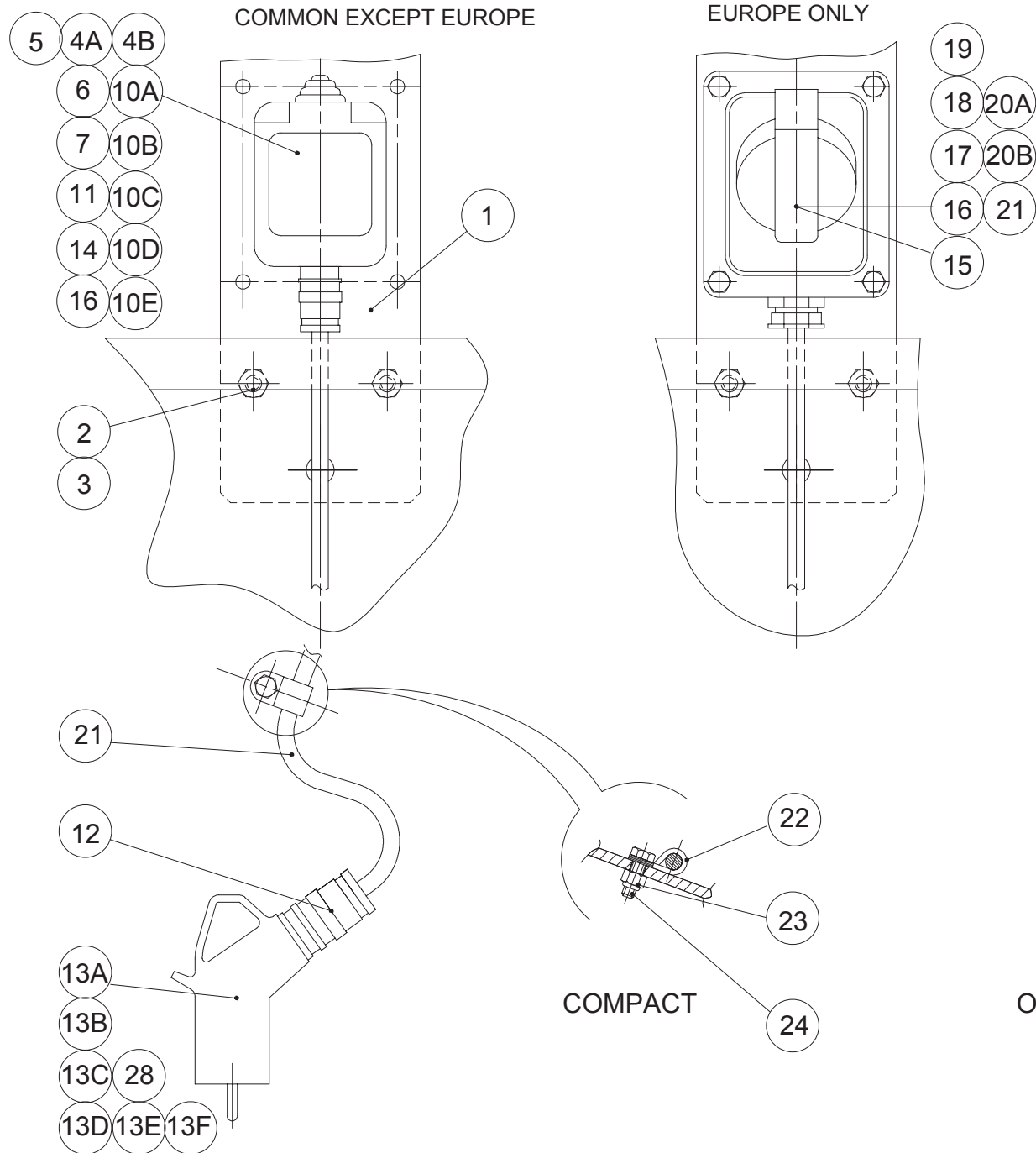

B 17024a

▲ Aliment. sur plateforme
Platform supply

EUR 115 V
115 V EUR

◀ D2
4/4 ▶

Rep.	Désignation	Designation	Specification	Qty	Code	Up to / jusqu'à
1	Support	Holder		1	118C150650	
2	Rondelle à dents	Tooth lock washer	DE 8ZB	3	2351301090	
3	Vis	Screw	H M8X20/20 CL8.8 ZB	3	2331231420	
15	Réducteur	Reducer		1	2421802260	
16	Presse-étoupe réd.		16/9	1	2441613020	
17	Vis	Screw	HM 6X20/20 8.8	4	2331231330	
18	Rondelle à dents	Tooth lock washer	DE 6ZB	4	2351301070	
19	Ecrou	Nut	H M6 CL 8 ZB	4	2341221050	
21	Câble	Cable	3G 2,5MM2	1	2440311750	
22	Collier	Collar	Ø8	1	2389001510	
23	Ecrou	Nut	M6 CL8ZB	1	2349221490	
24	Vis	Screw	HM 6X20/20 8.8	1	2331231330	
25	Vis	Screw	HM 6X16/16 8.8	1	2331231310	
26	Contre-écrou	Lock nut		1	2440314130	
27	Socle	Base	PC 16A 2P+T 110V	1	2441904690	
28	Fiche	Plug	16A 2P+T 110V	1	2440603940	
99	Prise 115V	« 115 V socket » label		1	3078151390	
99	Prise 115V	« 115 V socket » label		1	3078151380	

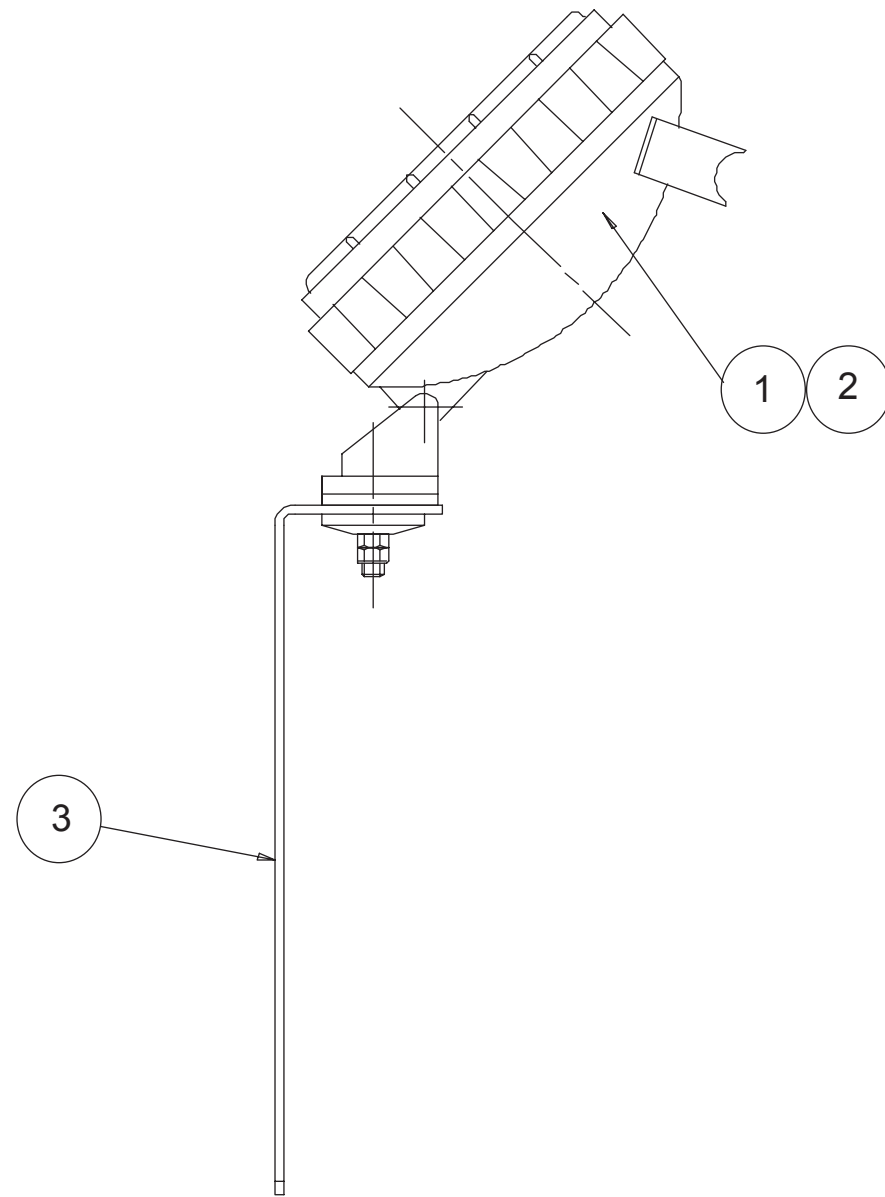

C15643

▲ Phare de travail Work headlight

◀ D3 ▶

Rep.	Désignation	Designation	Specification	Qty	Code	Up to / jusqu'à
1	Projecteur	Spotlight	24V	1	2441603160	
2	Lampe	Lamp	24V 70W	1	2441201630	
3	Support	Holder		1	118C150650	
4	Faisceau	Bundle	PROJ TRAVAIL	1	120C153340	

**▲ Chargeur 110 V
110 V charger**

◀ D4 ▶

Rep.	Désignation	Designation	Specification	Qty	Code	Up to / jusqu'à
	Chargeur 110V	charger	S5291	1	2440316690	
	Chargeur batterie	Battery charger	S5290	-1	2440316740	
	Collier	Collar	Ø8	1	2389001510	
	Collier de fixation	Cable clip	Ø6	-1	2389001500	

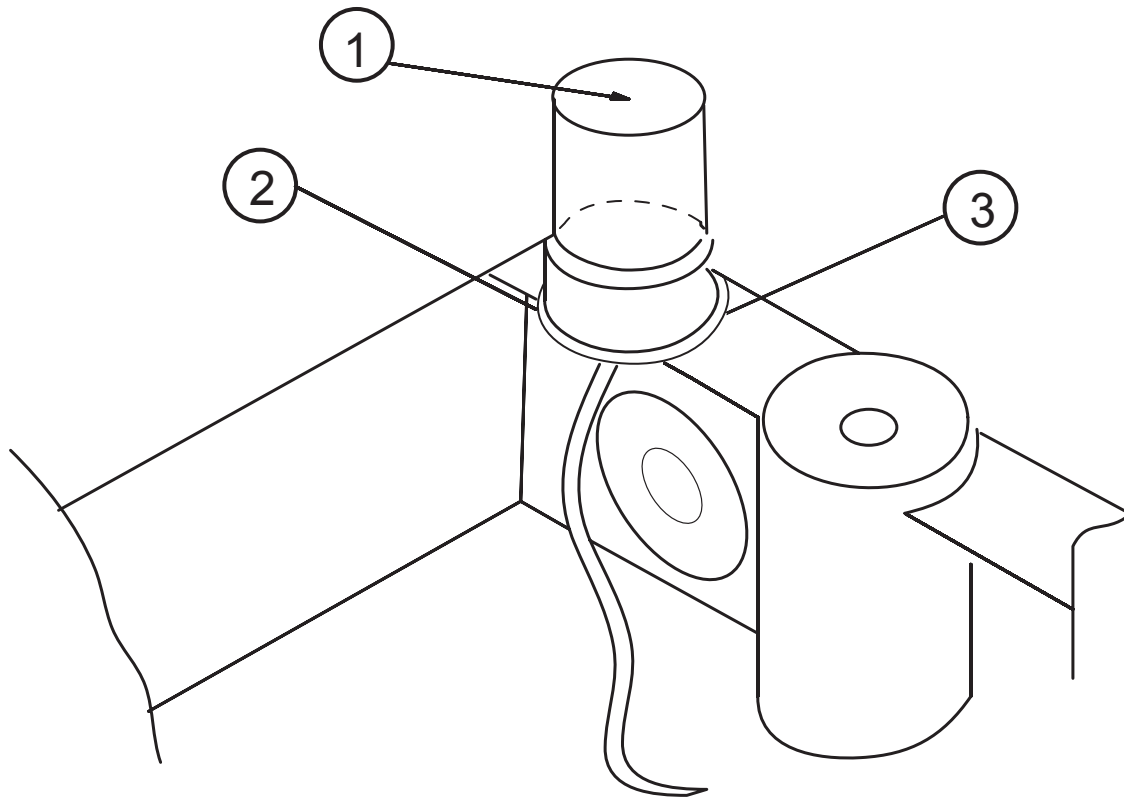

C17457

**▲ Feu à éclat
Flashing light****◀ D5 ▶**

Rep.	Désignation	Designation	Specification	Qty	Code	Up to / jusqu'à
1	Feu à éclat	Flashing light		1	118D169700	
	<i>Boîtier</i>	<i>Box</i>	<i>2 voies F</i>	1	2440203540	
	<i>Broche</i>	<i>Lock</i>		2	2440208040	
	<i>Feu à éclat</i>	<i>Flashing light</i>	<i>5W-12V</i>	1	2440600530	
	<i>Joint</i>	<i>Seal</i>		1	2441003250	
2	Socle	Base		1	118D169310	
3	Rivet	Rivet	TAPD	1	2421808280	
99	Inter. unipolaire levier	Single-pole toggle switch		1	2440901650	

CENTRALISED FILLING FOR 250Ah TROJAN BATTERY
REEMPLISSAGE CENTRALISE POUR BATTERIE TROJAN 250 Ah
H8SW-H10S- H12SN

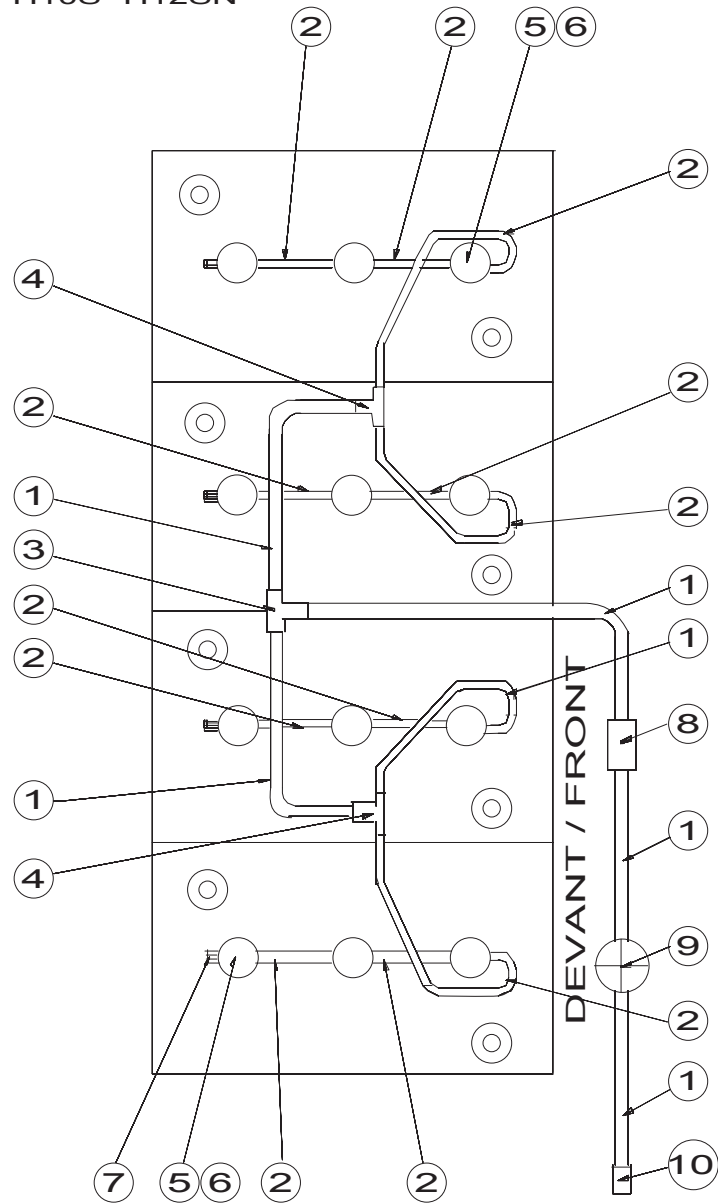

CENTRALISED FILLING FOR 180Ah TROJAN BATTERY
REEMPLISSAGE CENTRALISE POUR BATTERIE TROJAN 180 Ah
H8SN-H10N

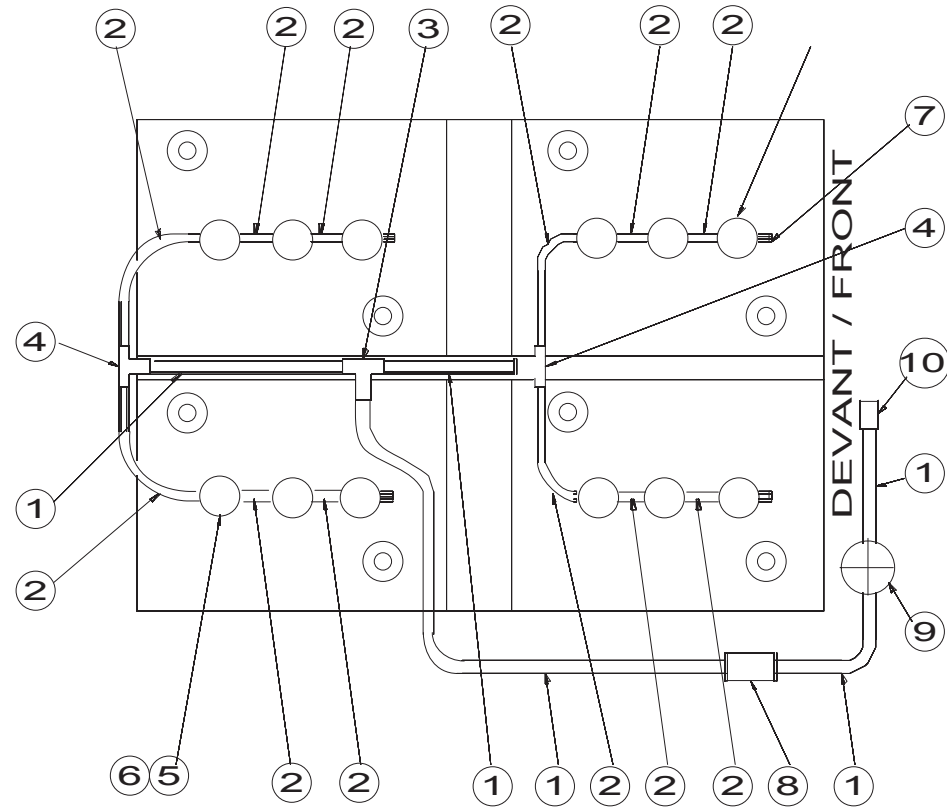

▲ Remplissage centralisé
Centralised filling

◀ **D6** ▶

Rep.	Désignation	Designation	Specification	Qty	Code	Up to / jusqu'à
1	Kit remplis. centralisé	Centralised filling kit		1	2421101760	
	<i>Té</i>	<i>T-piece</i>	<i>10x10x10</i>	1	2369199130	
	<i>Té</i>	<i>T-piece</i>	<i>6x10x6</i>	2	2369199140	
	<i>Tuyau</i>	<i>Pipe</i>	<i>Diam. 10/14</i>	1	2411902230	
	<i>Tuyau</i>	<i>Pipe</i>	<i>Diam. 6/10</i>	1	2411902240	
	<i>Bouchon obturateur</i>	<i>Plug</i>		4	2420210960	
	<i>Bouchon</i>	<i>Plug</i>		12	2420210970	
	<i>Flotteur</i>	<i>Floater</i>		12	2420601830	
	<i>Filtre</i>	<i>Filter</i>		1	2420602820	
	<i>Indicateur de flux</i>	<i>Flow indicator</i>		1	2440904180	
	<i>Raccord rapide</i>	<i>Rapid fastener</i>		1	2441801980	
2	Bidon	Can	5L	1	2420210940	

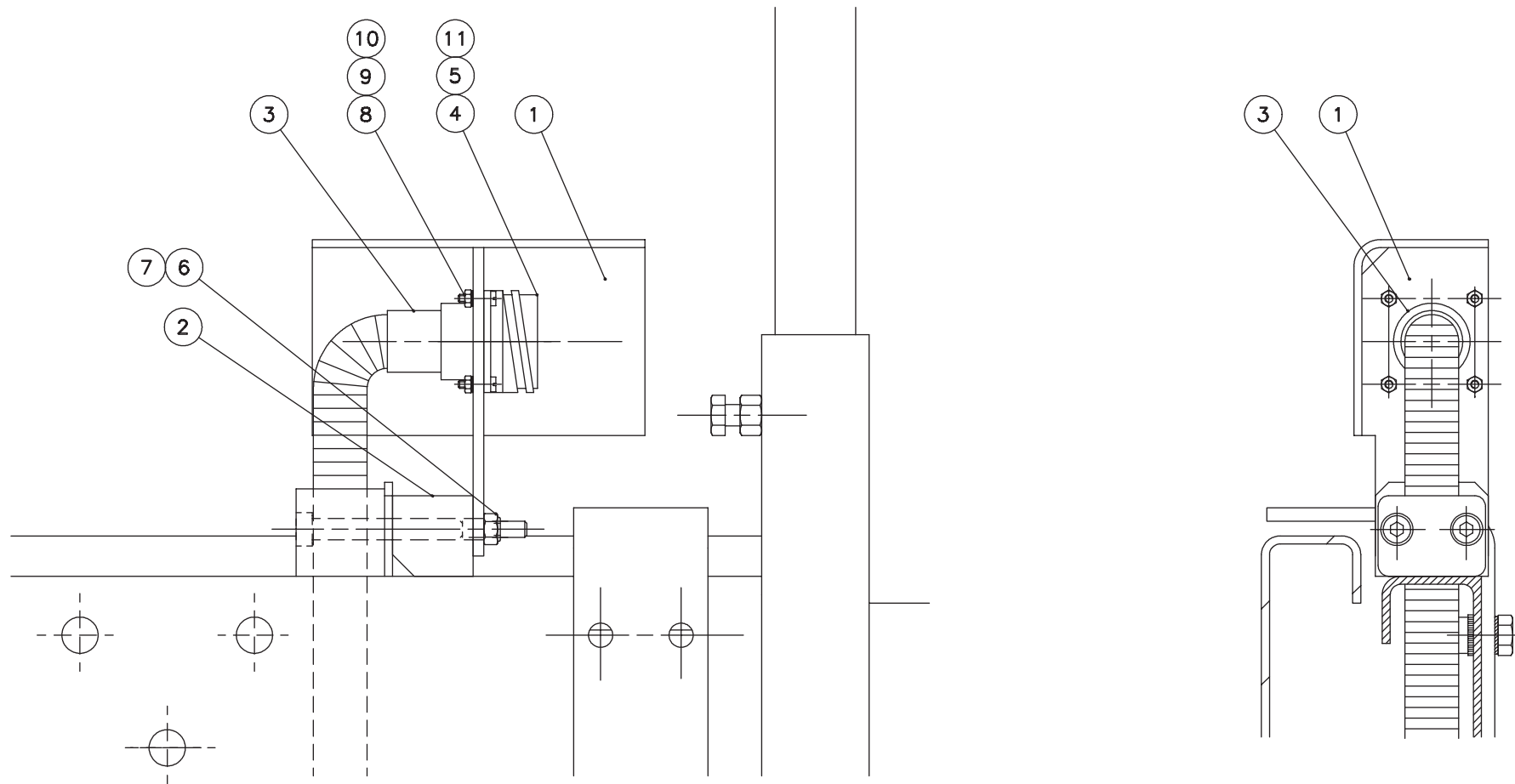

C16321

▲ Rallonge poste conduite
Operating station extension

◀ **D10** ▶

Rep.	Désignation	Designation	Specification	Qty	Code	Up to / jusqu'à
1	Faisceau	Bundle		1	118C163100	
2	Support câble	Cable support		1	118C163190	
3	Entretoise	Brace		1	118C163220	
4	Embase	Base	16x1	1	2440502970	
5	Broche	Lock		9	2440208070	
6	Adaptateur	Adaptor	15/16"-20 BVIRA U232	1	2440106410	
7	Vis	Screw	C M3X12 CL4.8ZB	4	2306311030	
8	Ecrou	Nut	H M3 CL 8 ZB	4	2341221010	
9	Rondelle à dents	Tooth lock washer	DE 3ZB	4	2351301030	
10	Vis	Screw	CHC M6 80/24 8.8	2	2308233790	
11	Ecrou	Nut	M6 CL8ZB	2	2349221490	

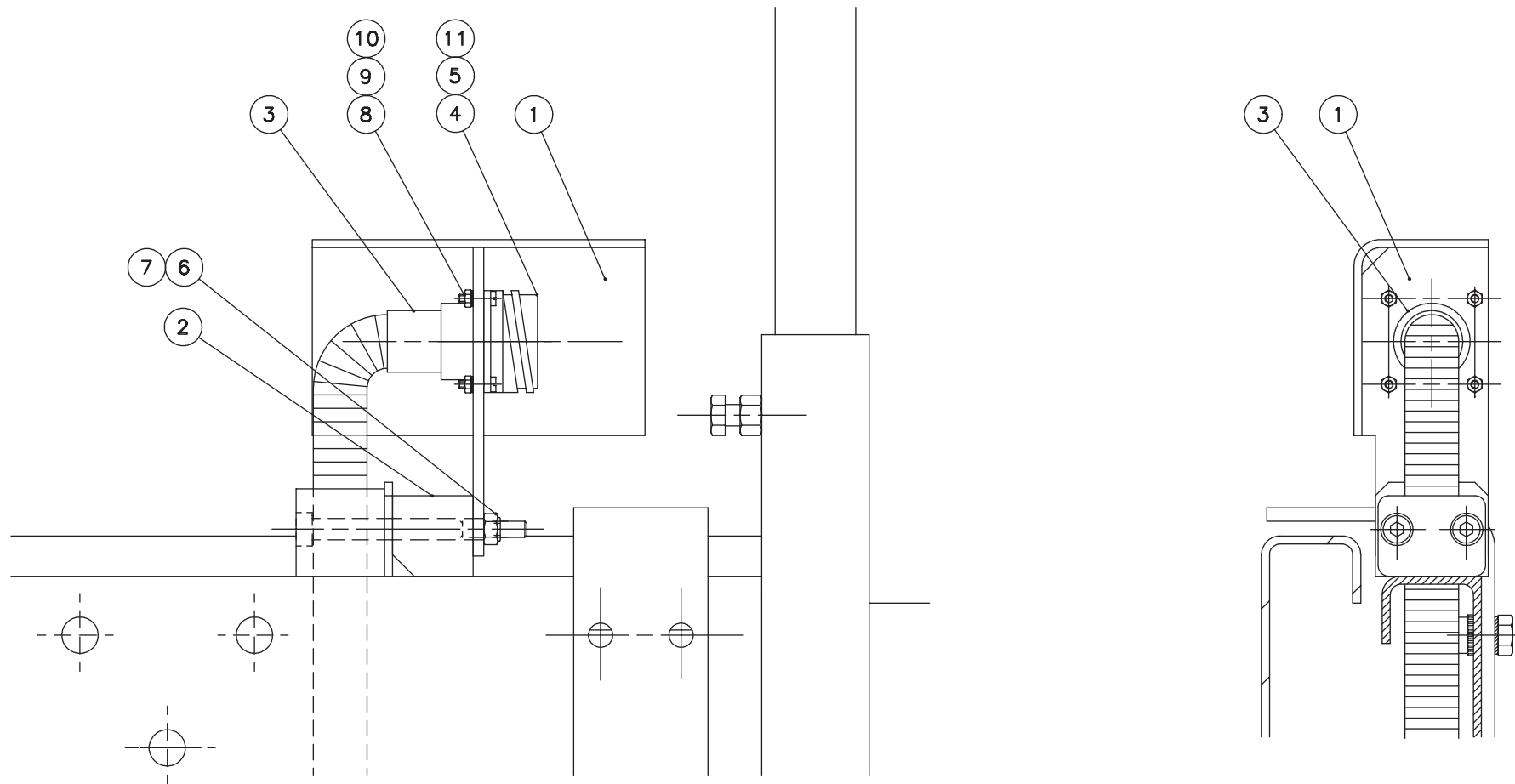

C16321

▲ **Huile biologique**
Organic oil

◀ **D12** ▶

Rep.	Désignation	Designation	Specification	Qty	Code	Up to / jusqu'à
99	Huile biodegradable	Biodegradable oil	USA	1	3078148920	
99	Huile biodegradable	Biodegradable oil	CEE	1	3078148890	
99	Huile hydraulique	« Hydraulic oil » label		-1	3078147140	
99	Huile hydraulique	« Hydraulic oil » label		-1	3078143520	

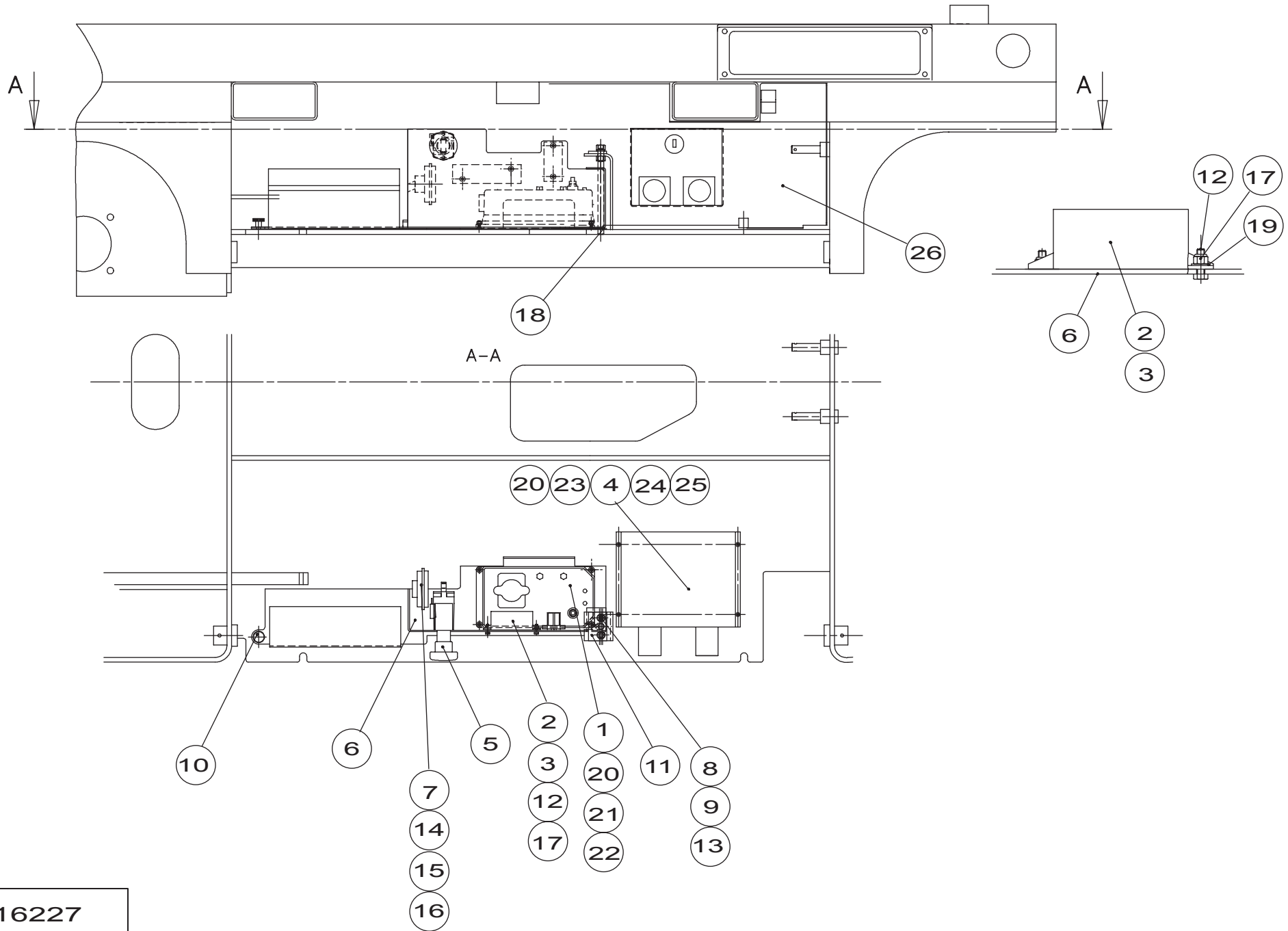

B16227

**▲ Chargeur bi-tension
Bi-voltage charger**

**◀ D14
1/2 ▶**

Rep.	Désignation	Designation	Specification	Qty	Code	Up to / jusqu'à
1	Variateur	Variable speed unit	24V/400AMP	1	2442201640	
2	Porte fusible	Fuse holder		1	2441608140	
3	Fusible	Fuse	MEGA FUSE 250 AMP	1	2440602480	
4	Chargeur batterie	Battery charger	110/220V	1	2440319300	
5	Coupe batterie	Battery cut-off		1	2440306180	
6	Support	Holder		1	118B157970	
7	Avertisseur	Buzzer	24V	1	2440103120	
8	Vis	Screw	H M10X25/25 8.8ZB	2	2331231560	
9	Rondelle à dents	Tooth lock washer	DE 10ZB	2	2351301110	
10	Vis moletée	Knurled screw	M6 L=12	1	2330003020	
11	Circuit imprimé	Printed circuit		1	118D160430	
12	Vis	Screw	HM 5X16/16 8.8	2	2331231210	
13	Rondelle plate	Flat washer	M10 U ZB	2	2351112090	
14	Vis	Screw	H M8X16/16 CL8.8 ZB	1	2331231400	
15	Rondelle à dents	Tooth lock washer	DE 8ZB	1	2351301090	
16	Ecrou	Nut	H M8 CL 8 ZB	1	2341221070	
17	Ecrou	Nut	M5 CL8ZB	2	2349222240	
18	Rondelle	Washer	Z12U	1	2351111080	
19	Rondelle plate	Flat washer	M5 U ZB	2	2351112040	
20	Rondelle à dents	Tooth lock washer	DE 5ZB	7	2351301060	
21	Ecrou	Nut	H M5 CL 8 ZB	3	2341221040	
22	Vis	Screw	F/90 M5X15/15 4.8ZB	3	2303329060	
23	Vis	Screw	CHC M5x16/16 8.8	4	2308231310	
24	Cosse	Lug	Ø4 (fiche)	2	2440305570	
25	Cosse	Lug	Ø4 (douille)	2	2440305560	
26	Capot DR	Right hood		1	118B162260	

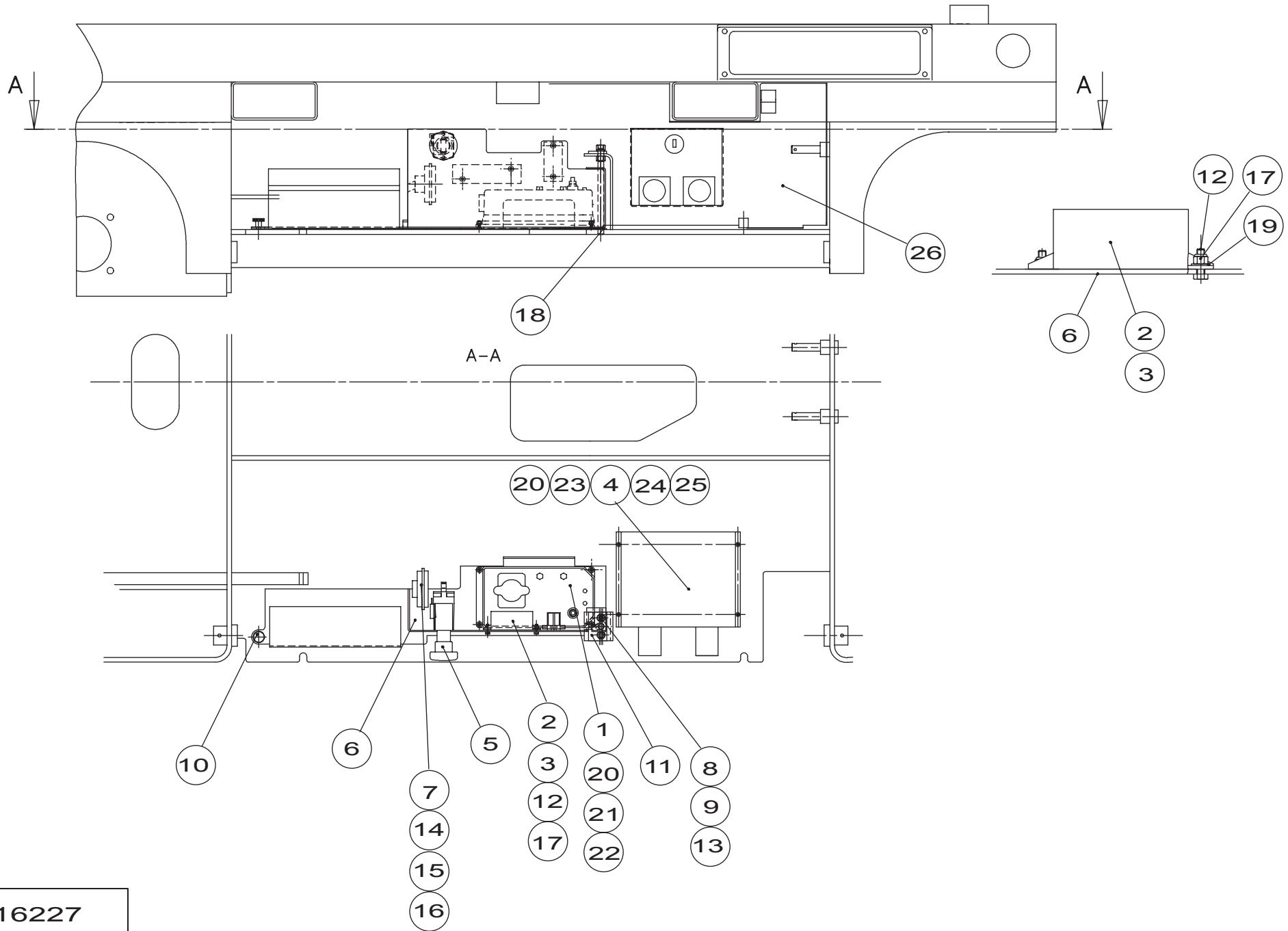

B16227

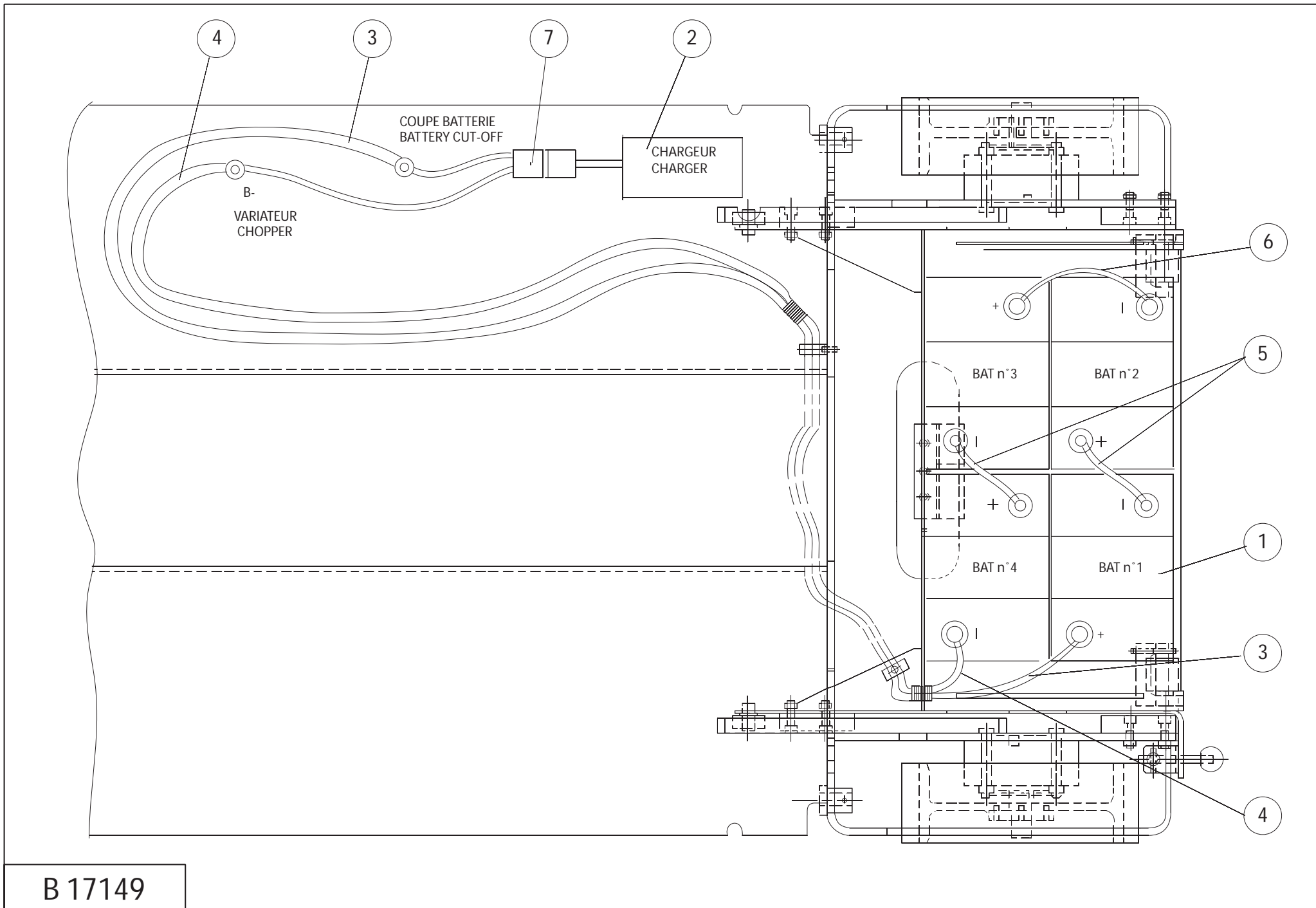

B 17149

▲ Batteries étanches
Sealed batteries

◀ D15 ▶

Rep.	Désignation	Designation	Specification	Qty	Code	Up to / jusqu'à
1	Ensemble batterie	Battery unit		1	2440208440	
2	Chargeur batt. Étanche	Sealed battery charger	S.5478	1	2440316850	
3	Câble	Cable	+BAT1 - CPEBAT	1	120C176150	
4	Câble	Cable	-BAT4 - VAR	1	120C176160	
5	Câble	Cable	+BAT -BAT 170	2	120C176170	
6	Câble	Cable	+BAT -BAT 250	1	120C176180	
7	Faisceau	Bundle	BAT - CHAR U	1	120C176190	
99	Chargeur batterie	Battery charger	S5290	-1	2440316740	
99	Batterie de traction	Traction battery		-4	2440208350	
99	Faisceau	Bundle	-BA N§2/+BA N§3	-3	119C153220	
99	Faisceau	Bundle	-BA N§1/CP BAT	-1	119C153160	
99	Faisceau	Bundle	-BA N§4/B-VAR	-1	119C153150	
99	Faisceau	Bundle	Bat 24V/Char U	-1	118C153440	

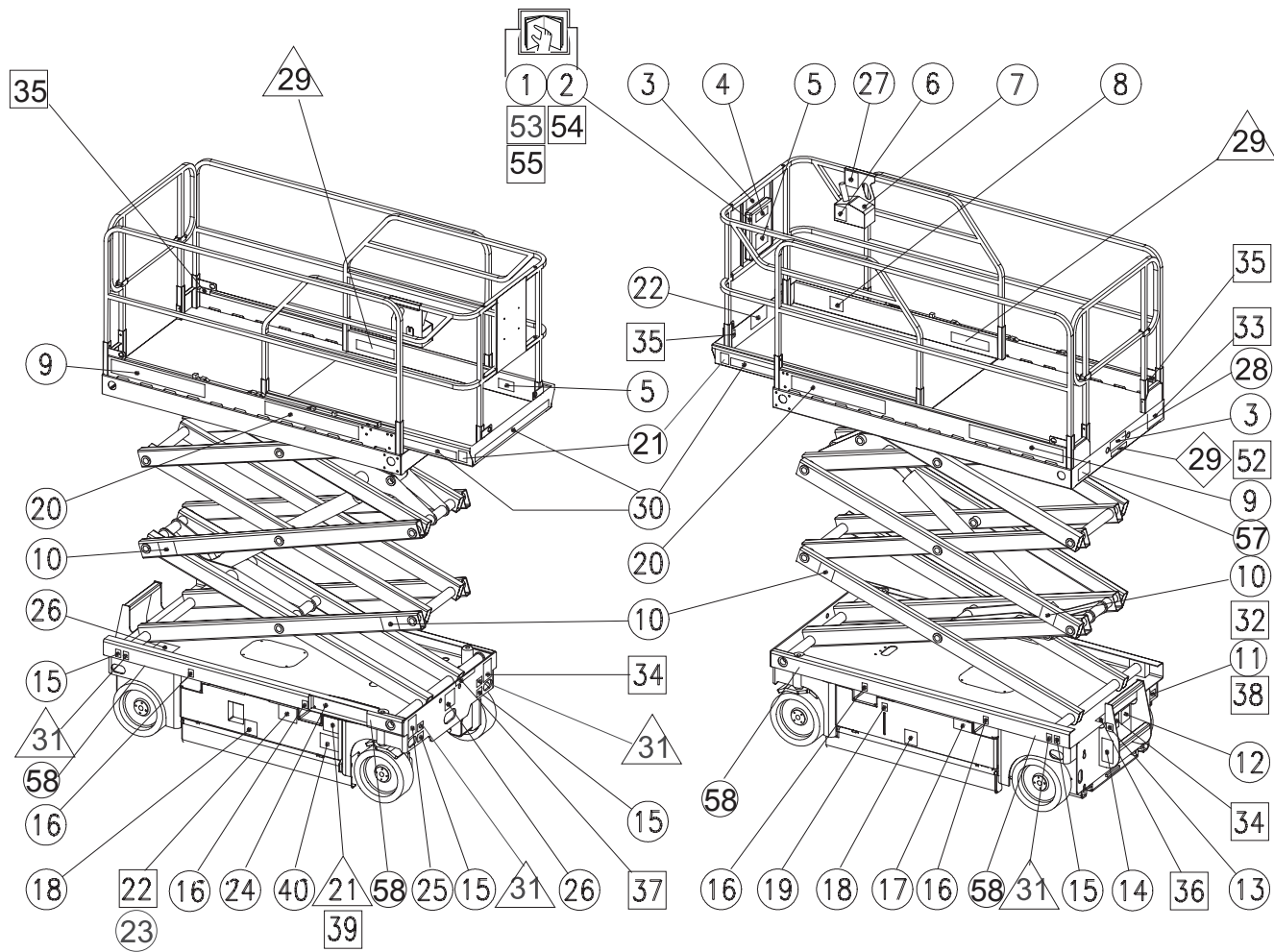

- Positions communes **tous pays** / Common positions - **all countries**
- △ Positions supplémentaires **Australie et Hollande** / Extra positions - **Australia and Holland**
- Positions supplémentaires **USA** / Extra positions - **USA**
- ◇ Positions supplémentaires **Italie** / Extra positions - **Italy**

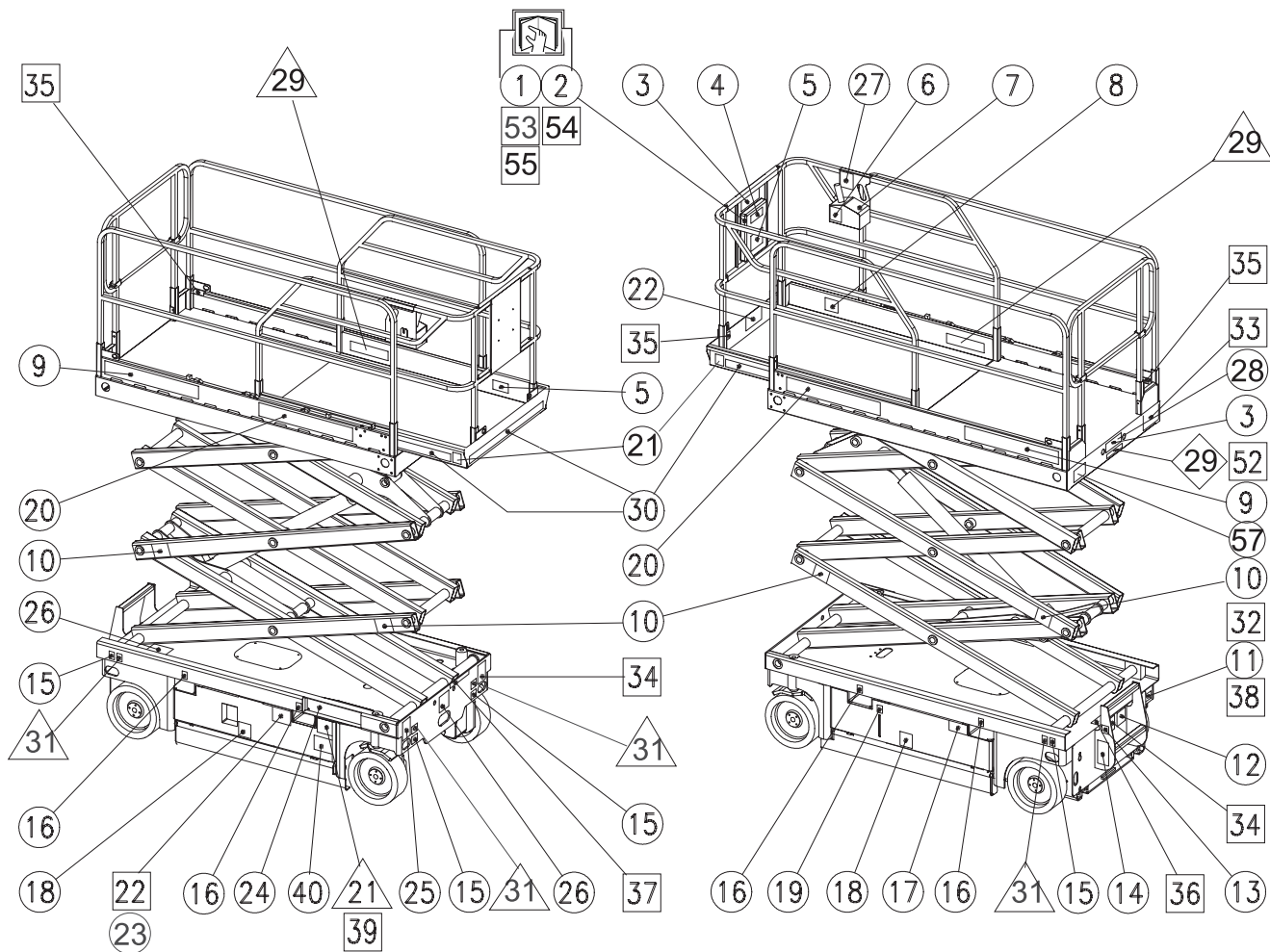

- Positions communes **tous pays** / Common positions - **all countries**
- △ Positions supplémentaires **Australie et Hollande** / Extra positions - **Australia and Holland**
- Positions supplémentaires **USA** / Extra positions - **USA**
- ◇ Positions supplémentaires **Italie** / Extra positions - **Italy**

D16106d

▲ Etiquettes communes

Common labels

Rep.	Désignation	Designation	Specification	Qty	Code	Up to / jusqu'à
1	Catalogue PR	Spare parts catalogue		1	2420327810	
3	Haut.plancher+charge	Floor height + load label		1	3078153730	Sf NL / excpt NL
4	Lire manuel ...	« Read manual » label		1	3078143680	
5	Sens translation	« Direction of travel » label		1	3078145100	
6	Charge batterie	« Battery charge » label		1	3078144630	
7	Pupitre nacelle	« Platform panel » label		1	3078151230	
8	Prise 240V	« 240 V socket » label	Etiquette/Label	1	3078143540	
9	Etiqu.	Label	"Compact 10"	2	3078145140	
10	Ecrasement main	« Hand crushing » label		4	3078149010	
11	Emplacement prise 240V	240V socket position		1	3078145730	
12	Port de vêtement...	« Wearing of clothes » label		1	3078143610	
13	Verrouillage tiroir...	« Lock spool » label		1	3078145310	
14	Entretien batterie	« Battery servicing » label		1	3078143510	
15	Crochet ancrage	« Anchoring hook » label		4	3078145110	
16	Fourche chariot	« Truck fork » label		4	3078143830	
17	Défreinage	« Brake release » label		1	3078152020	
18	Ecrasement pieds	«feet crushing » label	Etiquette/Label	2	3078144670	
19	Huile hydraulique	« Hydraulic oil » label		1	3078143520	
19	Huile biodégradable	Biodegradable oil	CEE	1	3078148890	
20	Graphisme	Logo	" HAULOTTE "	2	307P217080	
21	Ne pas stationner	« Do not park » park		2	3078143800	
22	Electrocution ...	« Electrocution » label		1	3078143810	
23	Masse soudure ...	« Welding earth » label		1	3078143600	
24	Pupitre bas	« Bottom panel » label		1	3078145060	
25	Dévers	« Tilt » label		1	3078144650	
30	Adhésif jaune et noir	Yellow and black adhesive marking		1	2421808660	

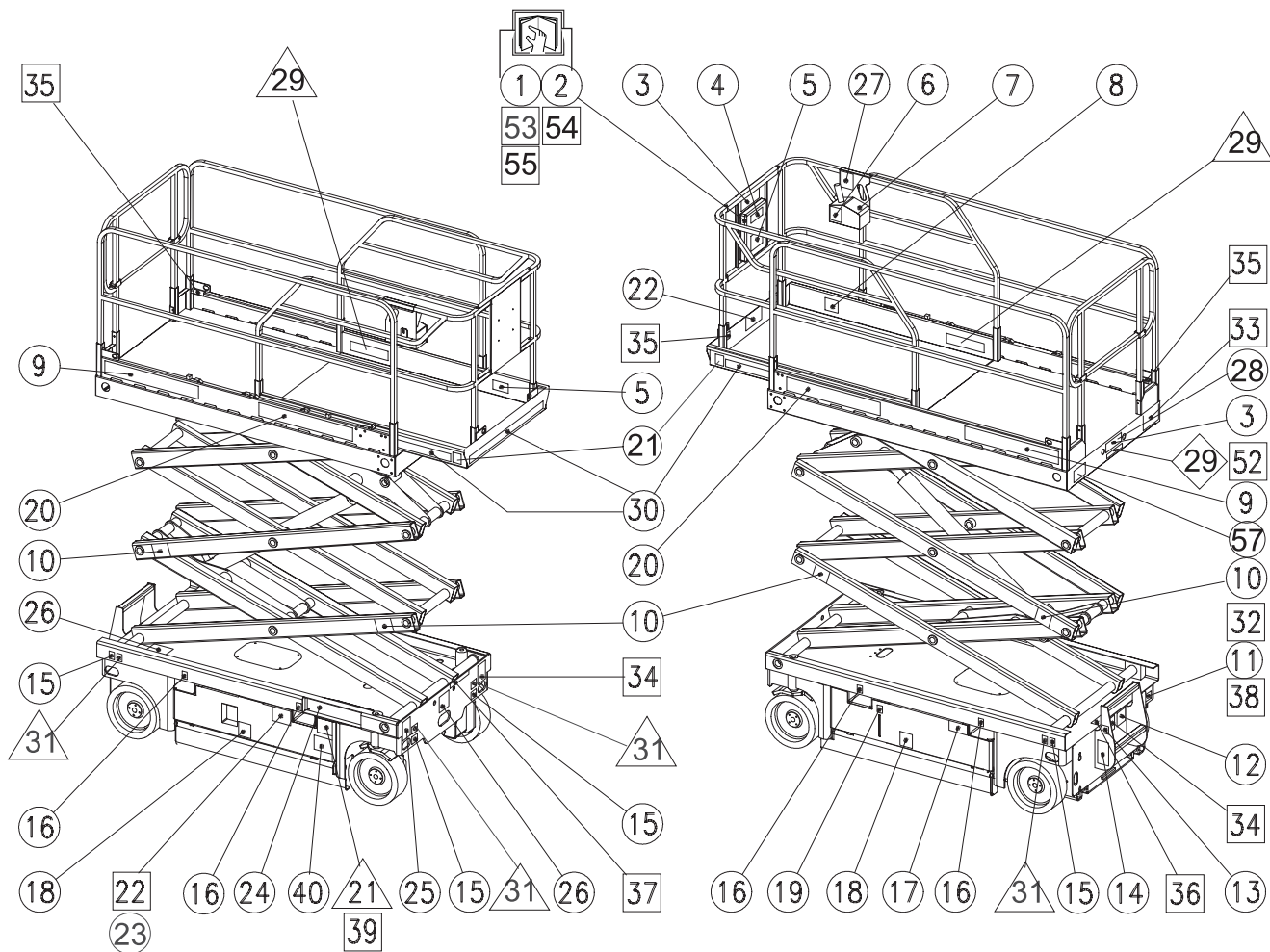

- Positions communes **tous pays** / Common positions - **all countries**
- △ Positions supplémentaires **Australie et Hollande** / Extra positions - **Australia and Holland**
- Positions supplémentaires **USA** / Extra positions - **USA**
- ◇ Positions supplémentaires **Italie** / Extra positions - **Italy**

D16106d

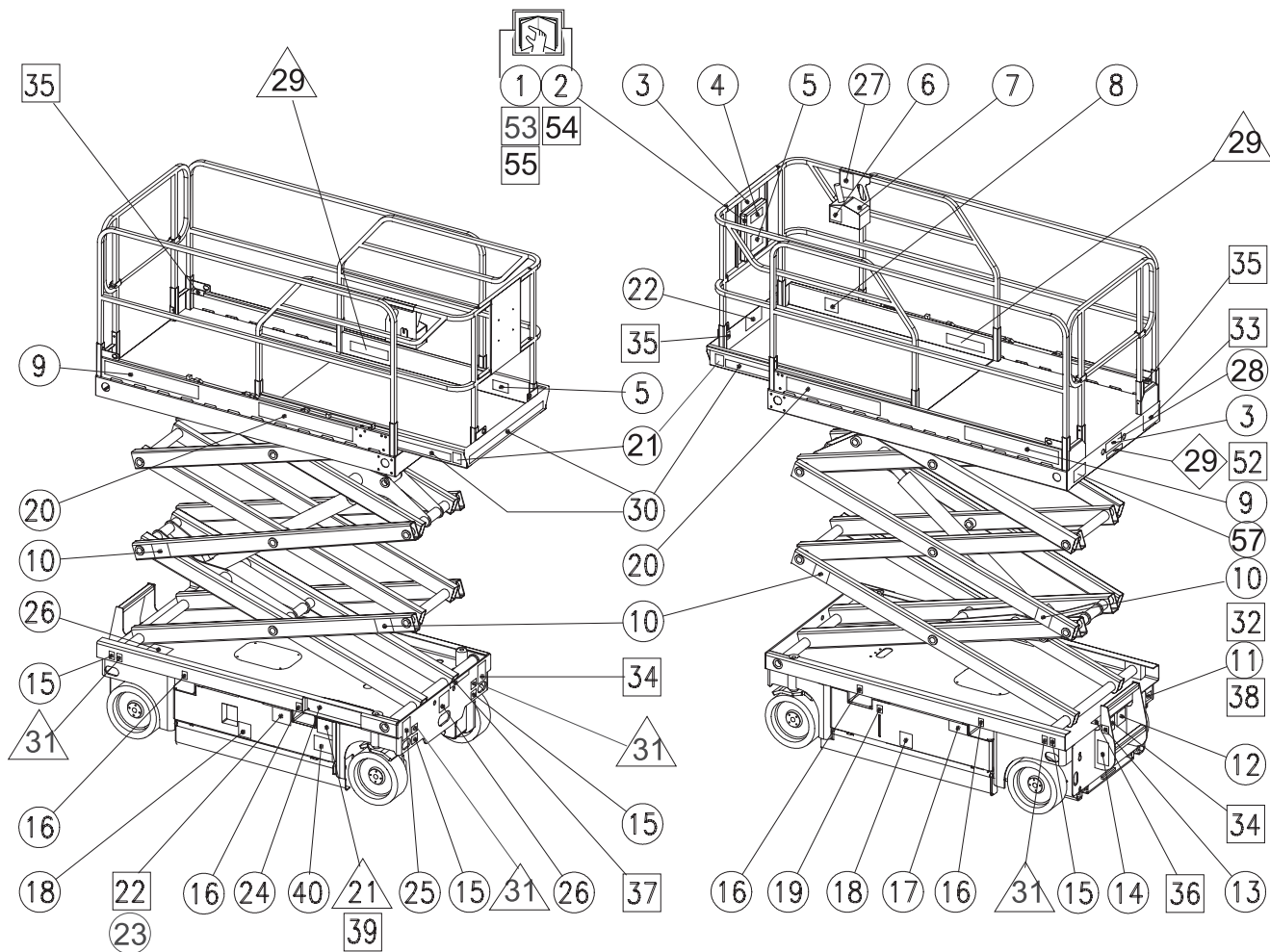

- Positions communes **tous pays** / Common positions - **all countries**
- △ Positions supplémentaires **Australie et Hollande** / Extra positions - **Australia and Holland**
- Positions supplémentaires **USA** / Extra positions - **USA**
- ◇ Positions supplémentaires **Italie** / Extra positions - **Italy**

D16106d

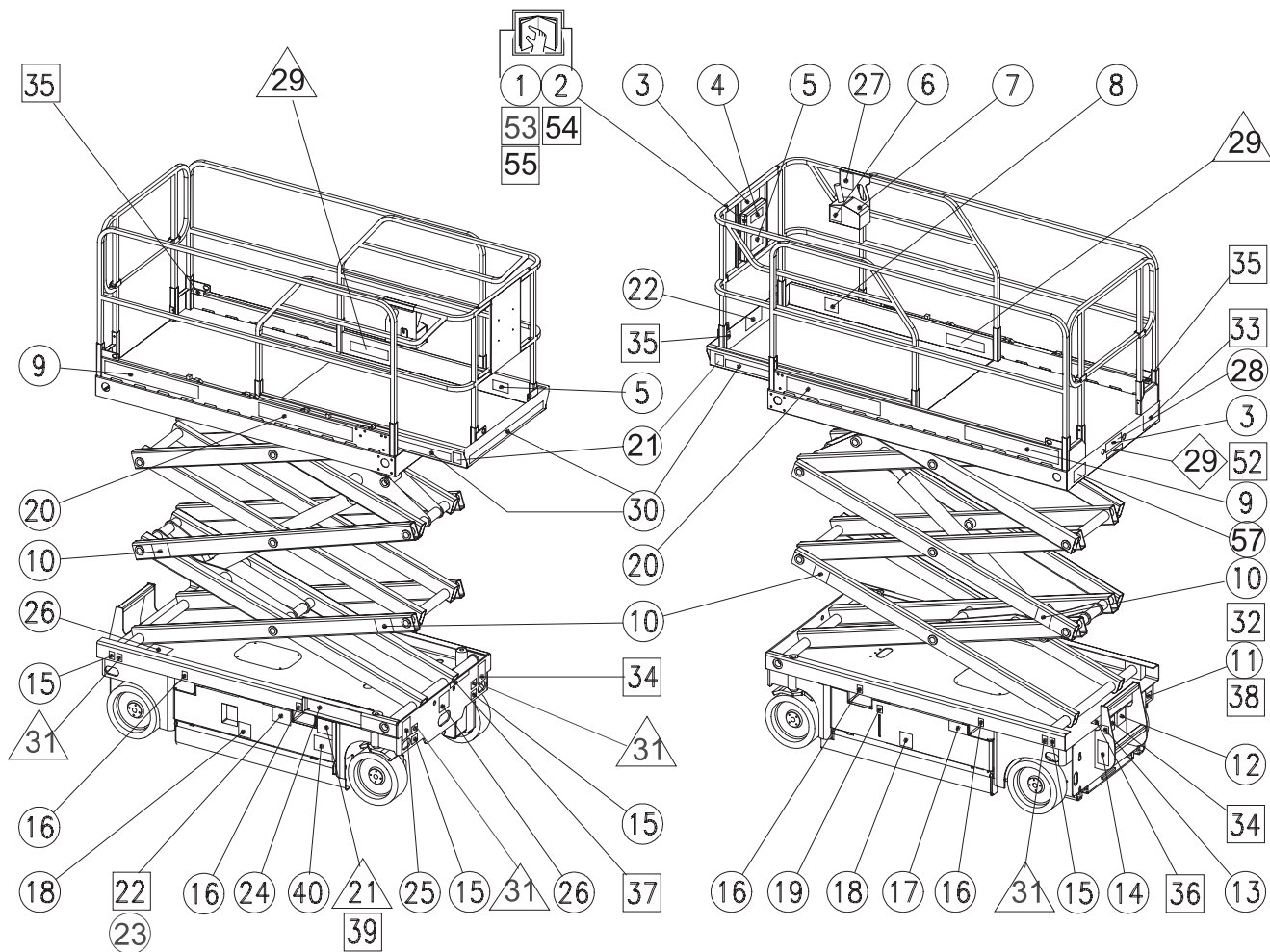

D16106d

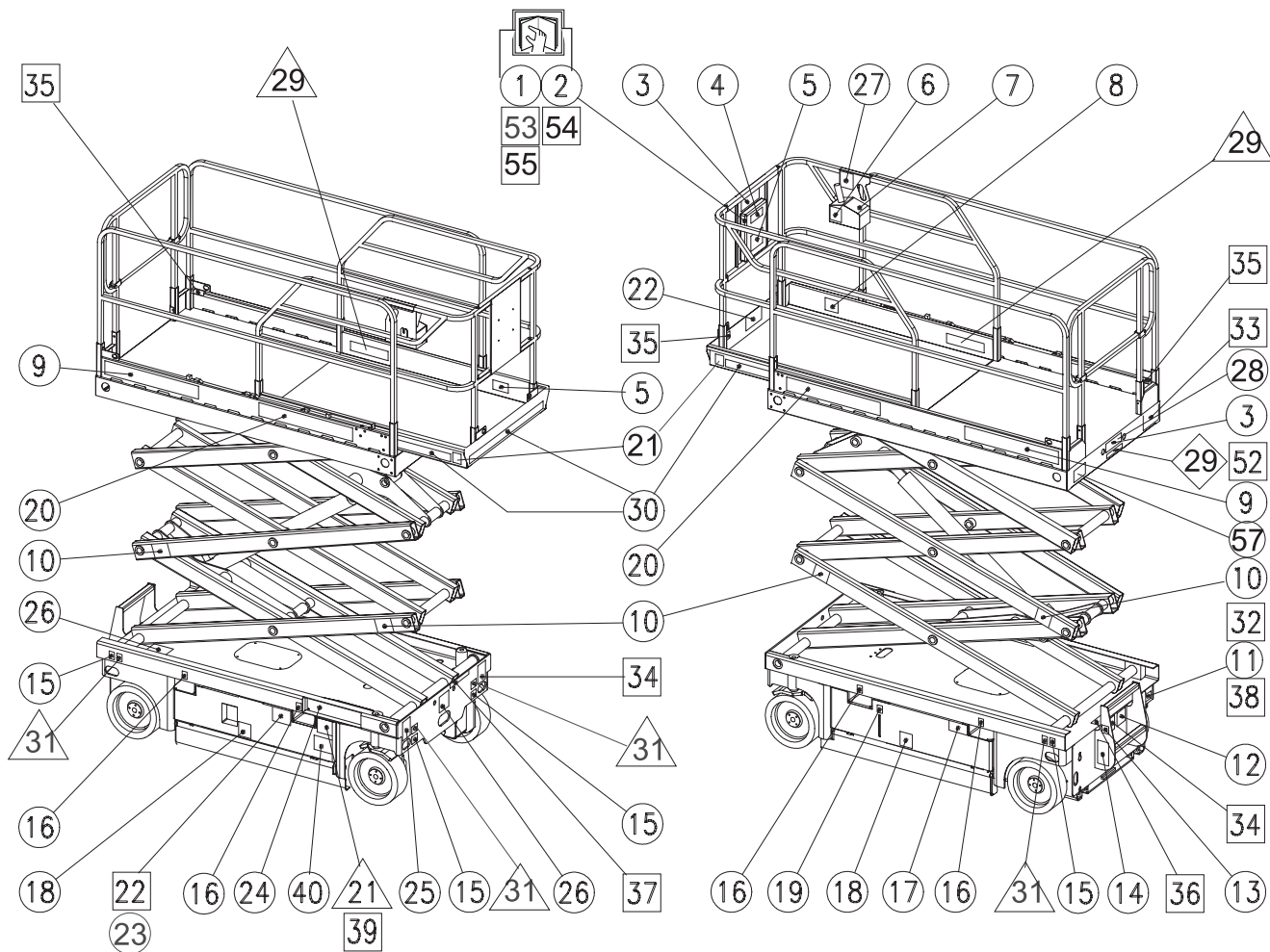

- Positions communes **tous pays** / Common positions - **all countries**
- △ Positions supplémentaires **Australie et Hollande** / Extra positions - **Australia and Holland**
- Positions supplémentaires **USA** / Extra positions - **USA**
- ◇ Positions supplémentaires **Italie** / Extra positions - **Italy**

D16106d

▲ Allemagne
Germany

Rep.	Désignation	Designation	Specification	Qty	Code	Up to / jusqu'à
2	Manuel CE	Operator's manual		1	2420326070	
3	HT plancher + charge	Floor height + load		-1	3078145370	
26	Plaque constructeur	Manufacturer's name plate		1	3078146200	
27	Arrêt descente	« Stop lowering » label		1	3078144700	
28	Consignes utilisation	« Operating instructions » label		1	3078149620	

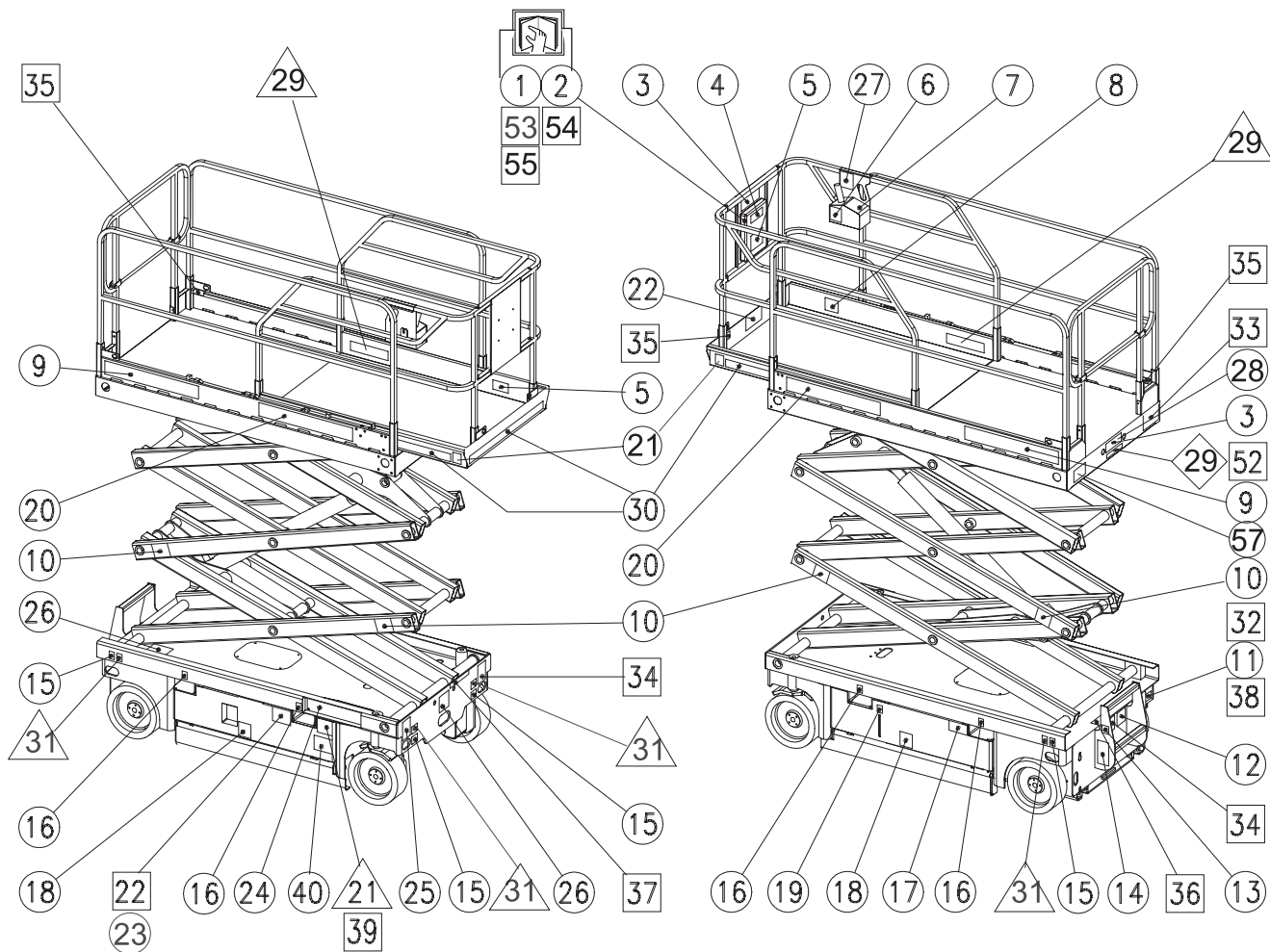

D16106d

**▲ Espagne
Spain**

◀ **E5** ▶

Rep.	Désignation	Designation	Specification	Qty	Code	Up to / jusqu'à
2	Manuel CE	Operator's manual		1	2420326090	
3	HT plancher + charge	Floor height + load		-1	3078145400	
26	Plaque constructeur	Manufacturer's name plate		1	3078146190	
27	Arrêt descente	« Stop lowering » label		1	3078144720	
28	Consignes utilisation	« Operating instructions » label		1	3078149630	

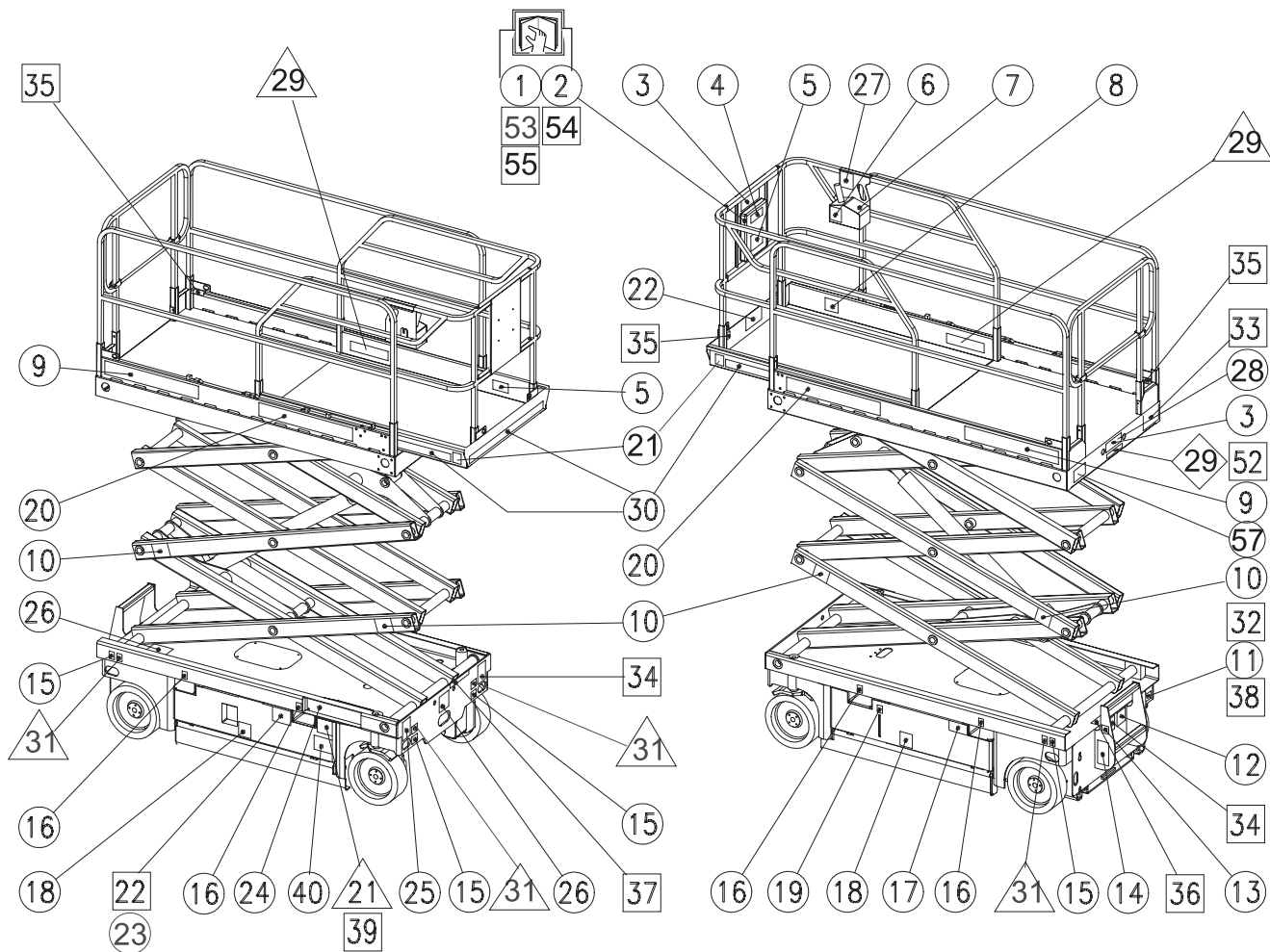

D16106d

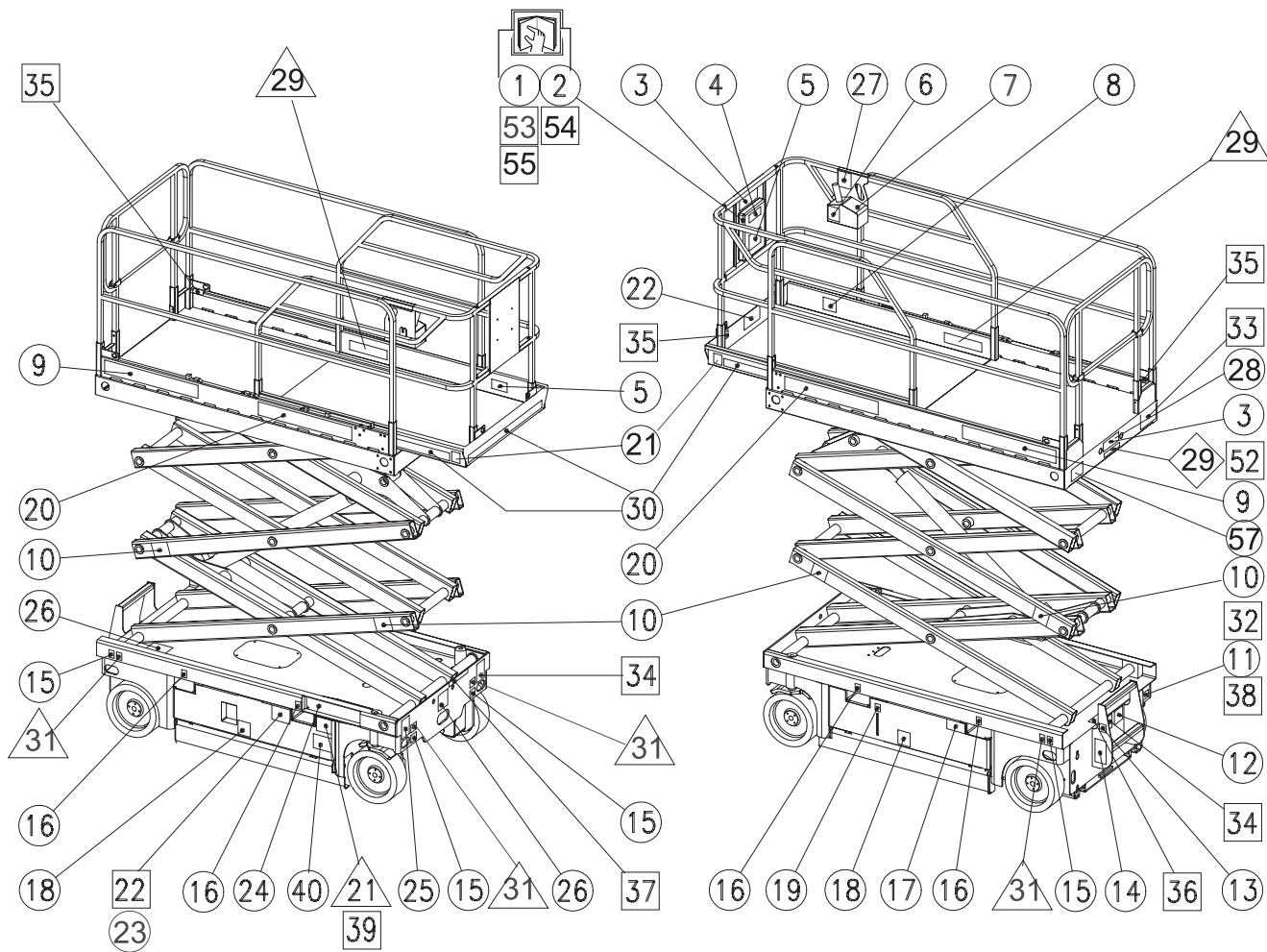

D16106d

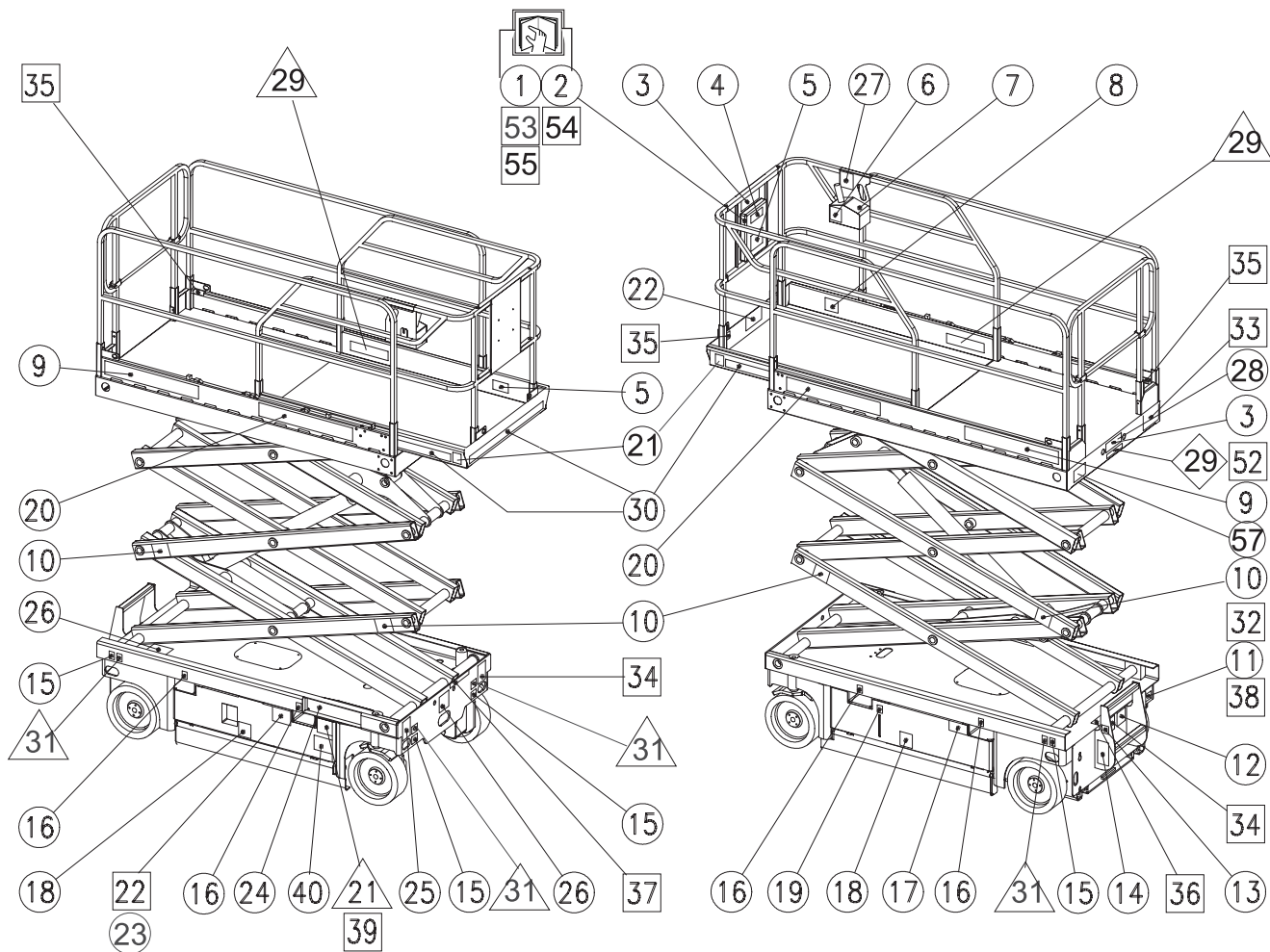

D16106d

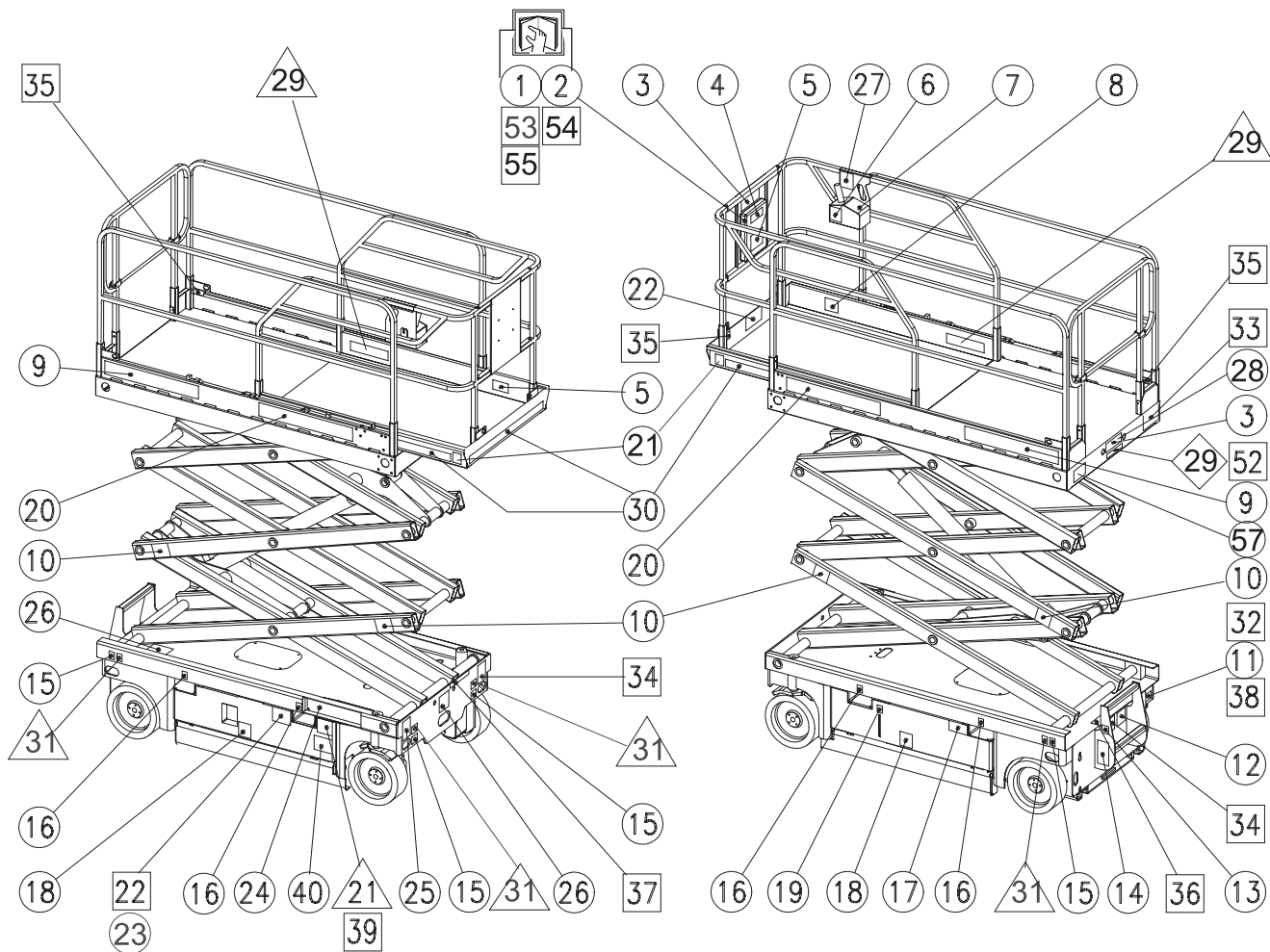

D16106d

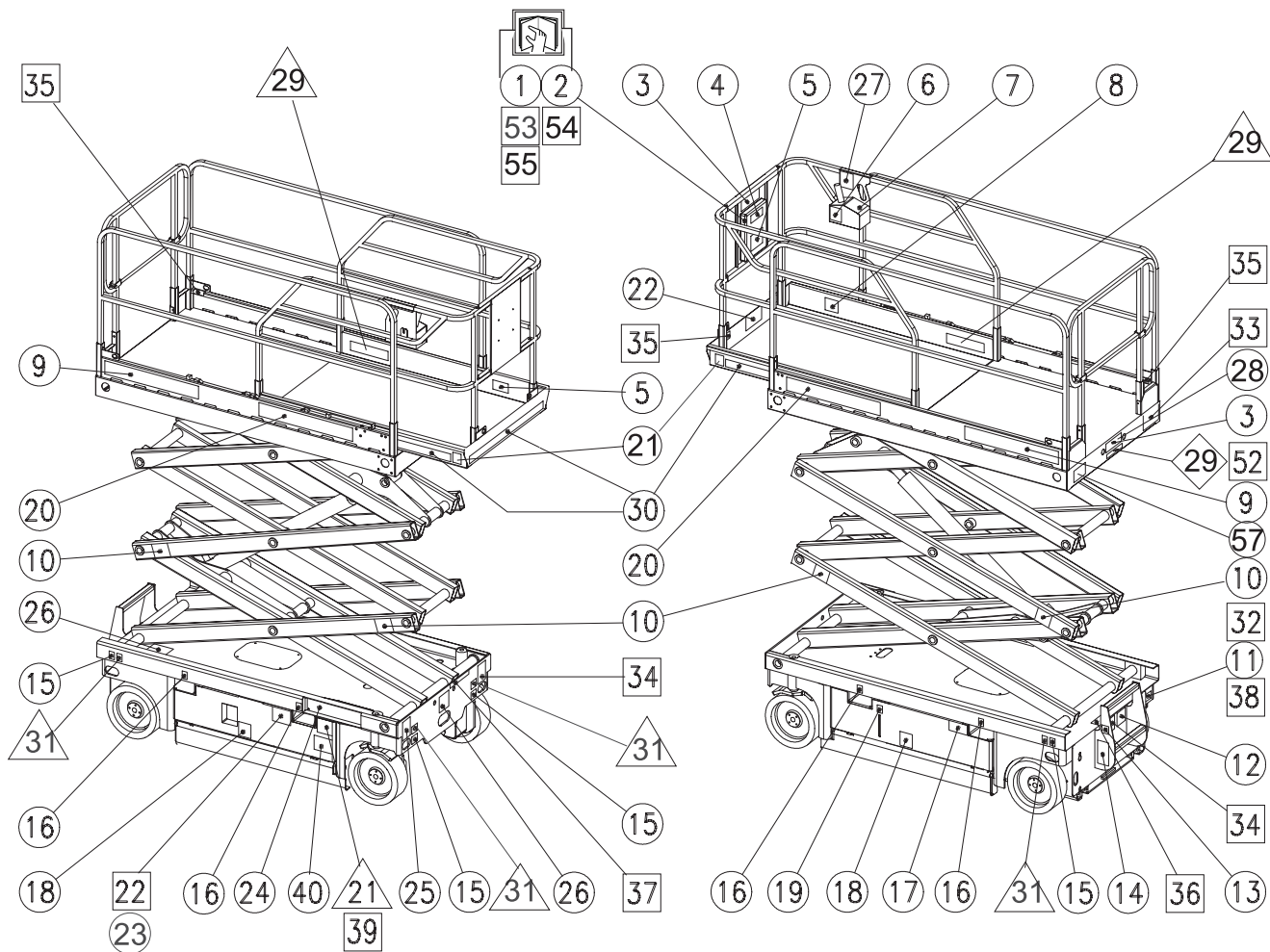

D16106d

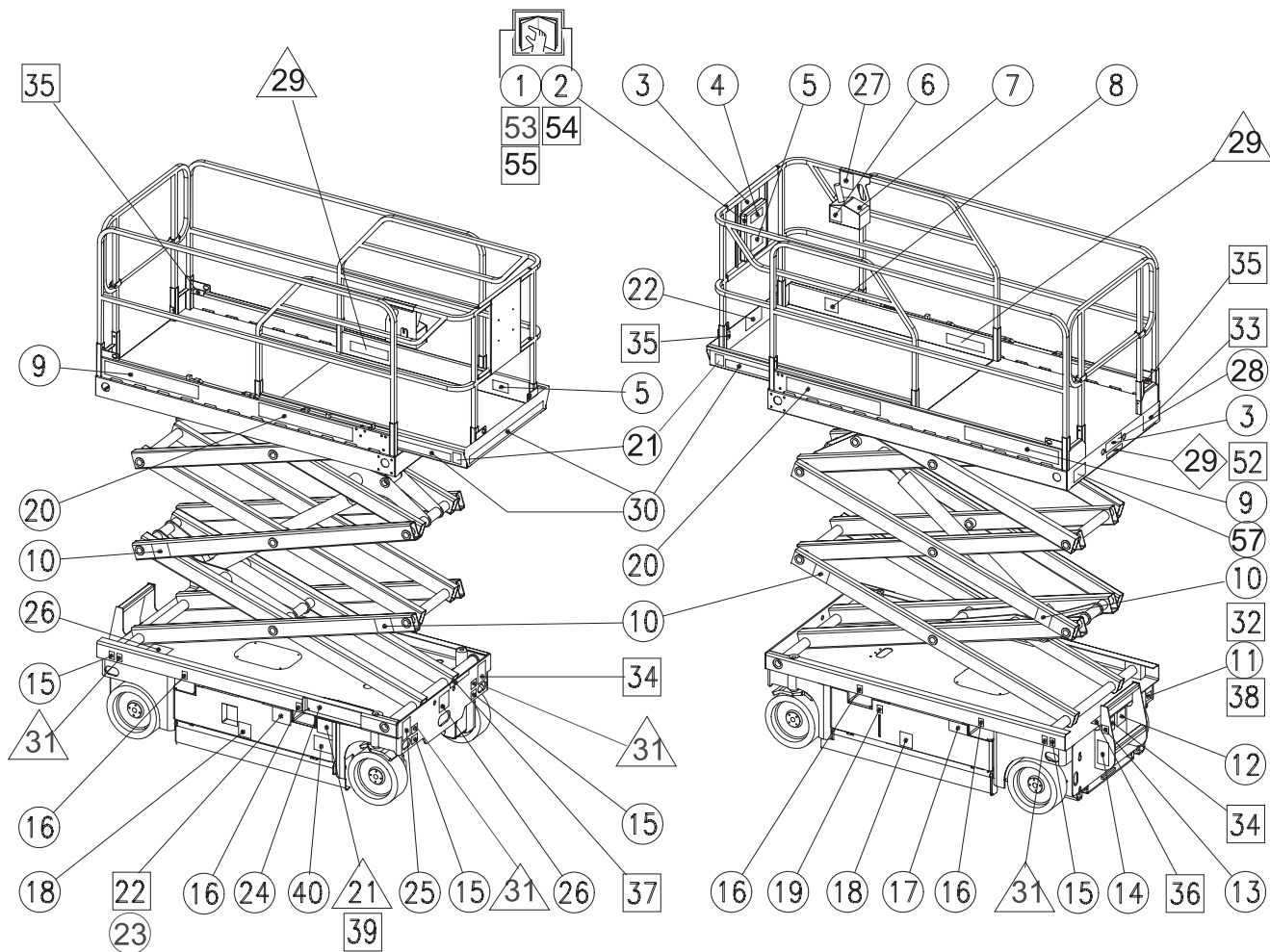

D16106d

▲ **Electricité**
Electricity



Rep.	Désignation	Designation	Specification	Up to / jusqu'à
1	Faisceau	Bundle		
2	Schéma électrique	Electric diagram		

▲ **Faisceau
Bundle**

◀ **F1** ▶

Rep.	Désignation	Designation	Specification	Qty	Code	Up to / jusqu'à
	Fiche	Plug	metal	1	2440603870	
	Adaptateur	Adaptor	1" 3/16-18	1	2440106290	
	Faisceau	Bundle	CHAS/PLATF.	1	120C153130	
	Faisceau	Bundle	Cp bat/Fus FU1	1	119C161630	
	Faisceau	Bundle	-BA	3	126C153220	
	Faisceau	Bundle	-BA N§1/CP BAT	1	119C153160	
	Faisceau	Bundle	-BA N§4/B-VAR	1	119C153150	
	Faisceau	Bundle	Bat 24V/Char U	1	118C153440	
	Faisceau	Bundle	Electro YV7&G1	1	119P238270	
	Faisceau	Bundle	Var T2/Ppe M1	2	118C153040	
	Faisceau	Bundle	Pupitre platf./Platform panel	1	118B169610	
	Faisceau	Bundle	Châssis/Chassis	1	120P236520	
	Faisceau	Bundle	Pupitre châss./Chassis panel	1	118B157960	
	Faisceau	Bundle	SQ7	1	120P240620	
	Câblage faisceau	Bundle wiring		1	120P243100	

English	Deutsch	Nederlands	Danska
"	Etiket "Overzicht symbolen"	I"	Etiket "Oversigt over symb « Tilt » label
« 110 V socket » label	Etikett "110V-Anschluß"	Etiket "Stekker 110V"	Etiket "110 V-stik"
« 115 V socket » label	Etikett "115V-Anschluß"	Etiket "Stekker 115V"	Etiket "115 V-stik"
« 230 V socket » label	Etikett "230V-Anschluß"	Etiket "Stekker 230V"	Etiket "230 V-stik"
« 240 V socket » label	Etikett "240V-Anschluß"	Etiket "Stekker 240V"	Etiket "240 V-stik"
« Anchoring hook » label	Etikett "Verankerungshaken"	Etiket "Ankerhaak"	Etiket "Fastspændingskrog"
« Battery charge » label	Etikett "Batterieladung"	Etiket "Accu laden"	Etiket "Batteriopladning"
« Battery servicing » label	Etikett "Wartung Batterie"	Etiket "Onderhoud accu"	Etiket "Vedligeholdelse af batteri"
« Bottom panel » label	Etikett "Schaltpult unten"	Etiket "Laag paneel"	Etiket "Nederste kontrolpanel"
« Brake release » label	Etikett "Lösen der Bremsen"	Etiket "Afremmen"	Etiket "Inaktivering"
« Direction of travel » label	Etikett "Fahrtrichtung"	Etiket "Translatierichtung"	Etiket "Køretning"
« Do not park » park	Etikett "Parkverbot"	Etiket "Niet parkeren"	Etiket "Parkering forbudt"
« Electrocution » label	Etikett "Berühungsgefahr"	Etiket "Elektrocutie"	Etiket "Elektrisk stød"
« Floor height... » label	Etikett "Fußbodenhöhe..."	Etiket "Hoogte van de vloer ..."	Etiket "Platformshøjde..."
« Platform panel » label	Etikett "Schaltpult Bühne"	Etiket "Paneel gondel"	Etiket "Kontrolpanel lift"
« Hand crushing » label	Etikett "Quetschungsgefahr Hände"	Etiket "Verplettingsgevaar handen"	Etiket "Masning af hånd"
« Hydraulic oil » label	Etikett "Hydrauliköl"	Etiket "hydraulische olie"	Etiket "Hydraulikolie"
« Lock spool » label	Etikett "Verriegelung Schubfach..."	Etiket "Vergrendeling schuif ..."	Etiket "Låsning af skuffe..."
« Operating instructions » label	Etikett "Bedienungshinweise"	Etiket "Gebruiksaanwijsties"	Etiket "Driftsanvisninger"
« Read manual » label	Etikett "Handbuch lesen"	Etiket "Handleiding lezen"	Etiket "Læs vejledning"
« Sling load » label	Etikett "Last Anschlagschlinge"	Etiket "Belasting strop"	Etiket "Last, hejsetov"
« Stop lowering » label	Etikett "Abschaltung Absenkung"	Etiket "Stilstand dalen"	Etiket "Stop nedsækning"
« Symbol summary » label	» label	Etikett "Symbolübersicht"	Etiket "Overzicht symbolen"
« Tilt » label	Etikett "Neigung"	Etiket "Overhelling"	Etiket "Hældning"
« Truck fork » label	Etikett "Wagen-Gabel"	Etiket "Wagenvork"	Etiket "Truckgaffel"
« Wearing of clothes » label	Etikett "Tragen von Schutzkleidung..."	Etiket "Dragen van kleding ..."	Etiket "Påklædning..."
« Welding earth » label	Etikett "Schweißmasse"	Etiket "Lasmassa"	Etiket "Svejsemne"
«feet crushing » label	Etikett "Quetschungsgefahr Füße"	Etiket "Verplettingsgevaar voeten"	Etiket "Masning af fod"
» label	Etikett "Symbolübersicht"	"	Etiket "Overzicht symbolen"
240V socket position	Etikett " Platz Stecker 240V"	Etiket "Plaatsing stopcontact 240V"	Etiket "Placering af 240V-stik"
Adaptor	Adapter	Adapter	Adapter
Adhesive charger protection	Schutz selbstklebendes Ladegerät	Bescherming zelfklevende lader	Selvklebende opladerbeskyttel
Adjustment washer	Einstellring	Regelring	Justeringskive

English	Deutsch	Nederlands	Danska
Anti-tipping over device	Kippschutz	Pothole	Tipsikring
Australia	Australien	Australië	Australien
Auxiliary contact	Hilfskontakt	Hulpcontact	Ekstra kontakter
Bag of seals	Satz dichtungen	Pakkingset	Pakningssæt
Ball	Kugel	Bol	Cylinderhoved
Barrier handrail	Geländer-Handlauf	Ketting balustrade	Håndgelænder
Base	Ansatz	Basis	Fodplade
Base	Sockel	Sokkel	Fundament
Battery box	Batteriekasten	Accubak	Batterihus
Battery charger	Akku-ladegerät	Acculader	Batterilader
Battery cut-off	Batterieabschaltung	Accuverbreker	Batterihus
Battery strap	Batteriegurt	Accurriem	Strop til batteri
Battery unit	Batterie	Batterijen	Batteri samlet
Bearing plate	Stützplatte	Steunplaat	Fodplade
Bend	Krümmer	Knie	Bøjning
Biodegradable oil	Abbaubares Öl	Biologisch afbreekbare olie	Biologisk nedbrydelig olie
Bi-voltage charger	Zwei-Spannungs-Ladegerät	Tweespanningslader	Dobbeltspændingsoplader
Bonding jumper	Masseband	Massastrip	Stelomfletning
Bottom part	Unterer bereich	Onderste gedeelte	Nederste del
Box	Kasten	Doos	Hus
Box	Schaltkasten	Kast	Skab
Brace	Zwischenstück	Tussenstuk	Mellemstykke
Braid (not felt)	Band (kein filz)	Niet-vilten galon	Kant ikke filt
Brake	Bremse	Rem	Bremse
Bundle	Kabelstrang	Bundel	Bundt
Buzzer	Warnhupe	Alarminrichting	Advarselssignal
Cable	Kabel	Kabel	Kabel
Cable clip	Befestigungsschelle	Bevestigingsbeugel	Fastspændingsklemme
Cable support	Kabelstütze	Kabelhouder	Kabelbøjle
Cables	Verdrahtung	Bedrading	Kabelføring
Caliper	Bügel	Bügel	Bøjle
Cam	Nocke	Nok	Knast
Can	Kanister	Bus	Dunk
Canada	Kanada	Canada	Canada
Central hydraulic plant	Hydraulikzentrale	Hydraulische centrale	Hydraulisk central

English	Deutsch	Nederlands	Danska
Centralised filling	zentralisiertes Füllen	Centraal vulsysteem	Central påfyldning
Centralised filling kit	Satz zentralisiertes Füllen	Kit centraal vulsysteem	Centraliseret påfyldningssæt
charger	Ladegerät	Lader	Oplader
Charger connection	Anschluss Ladegerät	Verbinding lader	Opladertilslutning
Chassis cover	Gehäusehaube	Chassis motorkap	Dækplade til chassis
Chock	Keil	Wig	Kile
Circlips	Sicherungsbügel	Klemmen	Låsering
Collar	Schelle	Band	Klemme
Common labels	Gemeinschaftsetiketten	Universele labels	Fælles mærkater
Connecting bar	Verbindungsstange	Verbindingsstang	Forbindelsesstang
Contact block	Schaltekörper	Compleet huis	Komplet kappe
Control block	Regulierungsblock	Besturingsblok	Justeringsklods
Control box	Steuerkasten	Bedieningskast	Styrehus
Control panel unit	Steuerstand	Geheel bedieningskast	Styrepanel samlet
Cylinder axis	Zylinderachse	Cilinderas	Cylinderaksel
Denmark	Dänmark	Denemarken	Danmark
Differential circuit breaker	Leistungsschutzschalter	Differentiële stroomonderbreker	Differentialafbryder
Direction lever	Lenkhebel	Stuurhendel	Løftestang til retning
Direction pivot	Lenkzapfen	Stuurpen	Styringsaksel
Distribution block	Verteilblock	Verdeelblok	Fordelingshus
Document box	Dokumentenfach	Documentenkast	Dokumenthus
Double hose clamp	Doppelte Klemmschelle	Dubbele klembeugel	Spændering dobbelt
Double-pole toggle switch	Zweipoliger Schalter mit Hebel	Tweepolige schakelaar met hendel	To-polet vippeafbryder
Drilling diagram	Bohrzeichnung	Boringsvlak	Boringsoversigt
Dry battery	Trockenbatterie	Droge batterij	Batteri af tørrelementer
Electric diagram	Stromlaufplan	Elektrisch schema	Elektricitetsskema
Electric socket on platform label	Etikett „Elektrostecker auf Plattform“	Label “Elektricitetsaansluiting op platform”	M
Electrical component kit	Set Elektrobestandteile	Kit elektriske element	Sæt el-komponenter
Electricity	Elektrizität	Elektriciteit	Elektricitet
Electropump	Elektropumpe	Elektropomp	Elektropumpe
Emergency control	Sicherheitssteuerung	Noodbediening	Sikkerhedsstyring
Emergency stop	Notabschaltung	Noodstop	Nødstop
End fitting	Endstück	Eindstuk	Endemuffe
End of travel	Endlage hub	Eindschakelaar Heffen	Endestop løft
Equal T-piece	Gleichseitiges t-stück	Gelijke T	T-stykker

English	Deutsch	Nederlands	Danska
Explosion risk label	Etikett "Explosionsgefahr"	Opschrift "Ontploffingsgevaar"	Etiket "Eksplussionsfare"
Extension rod	Pleuelstange Erweiterung	Stang extensie	Forlængerarm
Extension roller pin	Bolzenrolle Erweiterung	As rol extensie	Rulleakselforlænger
Exterior arm	Äusserer arm	Buitenste arm	Udvendige arm
Exterior right arm	Äusserer rechter arm	Buitenste arm rechts	Højre udvendige arm
Extract	Auszug	Aftreksel	Udtræk/Uddrag/Ekstrakt
Fastener	Klammer	Klem	Clips
Filter	Filter	Filter	Filter
Finland	Finnland	Finland	Finland
Flange	Flansch	Beugel	Beslag
Flanging tab	Verflanschungsfuß	Bevestigingshaak	Fastspændingsbeslag
Flashing light	Blinkfeuer	Schijnlicht	Blinklys
Flat washer	Flache unterlegscheibe	Platte ring	Flad skive
Flexible	Schlauch	Flexibele verbinding	Slange
Floater	Schwimmer	Vlotter	Svømmer
Floor height + load label	Etikett Auslegerhöhe + Last	Opschrift hoogte platform + belasting	Etiket Gulvhøjde og -belast
Flooring extension	Bodenerweiterung	Plaatverlenging	Udvidelse gulv
Flow indicator	Flussangeber	Stroomindicator	Flow indikator
Flush-fitting socket	einbaubare Buchse	Inbouwcontactdoos	Indbygget stik
Foam	Schaum	Schuimrubber	Skum
Frame	Gestell	Chassis	Chassis
Frame cowling	Abdeckung gestell	Kappen frame	Skærm til chassis
France	Frankreich	Frankrijk	Frankrig
Fuse	Sicherung	Zekering	Sikring
Fuse holder	Sicherungshalter	Zekeringhouder	Sikringsholder
Germany	Deutschland	Duitsland	Tyskland
Grease point	Schmiervorrichtung	Smeerpot	Smøreapparat
Grease point cover	Abdeckung schmiervorrichtung	Afdekking smeerpot	Holder til smøring
Green indicator light	Grüne LED	Groene verklikkerlicht	Grøn kontrollampe
Guardrail	Geländer	Reling	Rækværk
High Speed cut-off	Abschaltung hohe Geschwindigkeit	Uitschakelen H.S.	Afbrydelse Høj Hastighed
Holder	Halterung	Steun	Konsol
hood	Abdeckung	Kap	Kappe
Hydraulic diagram	Hydraulikschema	Hydraulisch schema	Hydraulisk skema
Hydraulic installation	Hydraulikanlage	Hydraulische installatie	Hydraulisk anlæg

English	Deutsch	Nederlands	Danska
Hydraulic motor	Hydraulikmotor	Hydraulische motor	Hydraulisk motor
Hydraulic reservoir assembly	Einheit wassertank	Eenheid hydraulisch reservoir	Hydrauliktank
Indicator	Anzeiger	Indicator	Indikator
Interior arm	Innerer arm	Binnenste arm	Indre arm
Intermediate guardrail	Zwischengeländer	Middelste beschermstang	Mellemrækværk
Italy	Italien	Italië	Italien
Key	Keil	Wigbout	Kile
Knurled screw	Rändelschraube	Gekartelde schroef	Riflet skrue
I"	Etiket "Oversigt over symb	« Tilt » label	Etikett "Neigung"
Label	Etikett	Etiket	Etikette
Labels	Etiketten	Etiketten	Etiketter
Lamp	Leuchte	Lamp	Lampe
Latch	Riegel	Pal	Lås
Left anti-tipping over device	Kippschutz links	Pothole links	Tipsikring, venstre
Left guardrail	Linkes Geländer	Linker beschermstang	Rækværk venstre
Left hood	Linke Schutzabdeckung	Linker kap	Venstre skærm
Left link	Linker schwingarm	Drijfstang links	Lille forbindelsesstang venstre
Left pivot	Linker drehzapfen	Linker pen	Tap venstre
lift cylinder	Hubzylinder	Hefcilinder	Løftecylinder
Link rod	Schwingarm	Drijfstang	Lille forbindelsesstang
LIXXBAIL label	Etikett "LIXXBAIL"	Opschrift "LIXXBAIL"	Mærkat "LIXXBAIL"
Load capacity label	Etikett "Lastkapazität "	Etiket "Laadvermogen"	Etiket "Ladekapacitet"
load capacity sticker	Aufkleber "Lastkapazität"	Sticker "Laadvermogen..."	Klistermærke "Bæreevne..."
Lobe wheel	Keulenrad	Gelobt stuur	Håndhjul med knaster
Lock	Spindel	Pen	Tap
Lock nut	Bremsmutter	Moer rem	Møtrik bremse
Lock nut	Gegenmutter	Contramøer	Kontramøtrik
Locking pin	Verriegelungsbolzen	As blokkeermechanisme	Låseaksel
Logo	Graphik	Opschrift	Skrift
Lug	Kabelschuh	Poolklem	Polsko
Male union piece	Anschlußstück mit außengewinde	Intredende verbinding	Samling han
Manual	Handbuch	Handboek	Manual
Manual of responsibilities	Verantwortlichkeitshandbuch	Handboek van verantwoordelijkheid	Håndbog om ansvarsområder
Manufacturer's name plate	Firmenschild des Herstellers	Plaat van de constructeur	Fabrikantskilt
Minimess tap	Minimess-anschluß	Minimess aansluiting	Stik

English	Deutsch	Nederlands	Danska
Motor guiding axle	Antriebsführungsachse	Drijf/stuuras	Motoraksel
Mushroom-headed button	Faustschlagknopf	Drukknop vuisslag	Håndpumpe-knap
Netherlands	Holland	Holland	Holland
Non-slip adhesive tape	Rutschfestes Haftmittel	Anti-slip-sticker	Skridsikker tape
Nut	Mutter	Moer	Møtrik
Oil filter	Ölfilter	Oliefilter	Oliefilter
Operating station extension	Verlängerung am Leitungsposten	Verlengstuk van stuurhuis	Overbygning på kontrolpanel
Operator's manual	Bedienungs- und Wartungshandbuch	Besturings- en onderhoudsinstructies	EU-betjeningsvejledning
Operator's manual	Bedienerhandbuch	Operator's manual	Bruger manual
Option	Option	Optie	Ekstraudstyr
Organic oil	biologisches Öl	Biologische olie	Biologisk olie
O-ring	O-ringdichtung	Afdichtring	O-ring
Owner's manual	Besitzerhandbuch	Owner's Manual	Brugervejledning
Packing box	Stopfbüchse	Pakkingbus	Pakdåse
Pad	Unterlage	Glijder	Klods
Pedal	Pedal	Pedaal	Pedal
Permitted load label	Etikett Höchstlast	Opschrift "Toegestane belasting"	Mærkat "Tilladt belastning"
Pin	Achse	As	Aksel
Pin	Stift	Pen	Metalstift
Pipe	Rohr	Pijp	Rør
Plate	Blech	Plaat	Plade
Plate mounting unit	Montageset Platine	Geheel montage plaat	Monterings sæt plade
Platform	Arbeitsbühnenplattform	Platform korf	Liftplatform
Platform	Plattform	Platform	Platform
Platform control box	Schaltkasten Bühne	Kast gondel	El-kasse kurv
Platform safety barrier	Plattformgeländer	Railing platform	Gelænder på platform
Platform supply	Versorgung auf Plattform	Voeding op platform	Forsyning på platform
Platform with foldable guard rail	Plattform mit umklappbarem Geländer	Platform met neerklapbare leuning	Platform med n
Plug	Stecker	Fiche	Stik
Plug	Stopfen	Plug	Studs
Plug	Verschlussstöpsel	Afsluitdop	Stopprop
Plug socket	Anschluß	Aansluiting	Stik
Portugal	Portugal	Portugal	Portugal
Position switch	Positionsschalter	Positieschakelaar	Stillingskobler
Pothole cylinder	Stabilisatorzylinder	Pothole vijzel	Donkraft i jorden

English	Deutsch	Nederlands	Danska
Pressure controller	Kontakt druckmesser	Handcontact	Trykkobler
Printed circuit	Bedruckte leiterplatte	Gedrukte schakeling	Trykt kredsløb
Protective cover	Schutzhaube	Beschermkap	Beskyttelsesskærm
Protective plate	Schutzplatte	Beschermingsplaat	Beskyttelsesplade
Rail	Handlauf	Handlijst	Lønning
Rapid fastener	Schnellanschluss	Snelkoppeling	Hurtig tilslutning
Rear axle	Hinterachse	Achteras	Bagaksel
Red light indicator	Rote Kontrolleuchte	Rood verklikkerlampje	Rød indikatorlampe
Reducer	Getriebe	Vertrager	Reduktor
Relay	Relais	Relais	Relæ
Remote control	Fernbedienung	Afstandsbesturing	Fjernbetjening
Repair manual	Reparaturhandbuch	Repair manual	Reparationsmanual
Retaining bracket	Befestigungseisen	Bevestigingspoot	Fastgørelsestep
Right anti-tipping over device	Kippschutz rechts	Pothole rechts	Tipsikring, højre
Right guardrail	Rechtes Geländer	Rechter beschermstang	Rækværk højre
Right hood	Rechte Schutzabdeckung	Rechter kap	Højre skærm
Right link	Rechter schwingarm	Drijfstang rechts	Lille forbindelsesstang højre
Ring	Ring	Ring	Ring
Rivet	Niet	Niet	Nitte
Roller	Rolle	Wieltje	Rulle
Rotary knob with key	Drehknopf mit schloss	Draaiknop met sleutel	Drejeknap med nøgle
Rubber ring	Gummiring	Elastische ring	Elastik ring
Rubber washer	Flexible unterlegscheibe	Elastische ring	Sikringssskive
Safety manual	Sicherheitshandbuch	Safety manual	Sikkerhedsmanual
Safety support	Sicherungswinkel	Veiligheidswinkelhaak	Sikkerhedsvinkel
Scissor lift platform unit	Scheren	Samenstel schaar	Saksudstyr
Screw	Schraube	Schroef	Skruer
Seal	Dichtung	Pakking	Samling
Seal	Verschluss	Afsluiter	Pakningsventil
Sealed batteries	Abgedichtete Batterien	Verzegelde accu's	Vandtætte batterier
Sealed battery charger	Abgedichtetes Batterieladegerät	Verzegelde-accu-lader	Vandtæt batterioplader
Sealed empty box	dichtes Leergehäuse	Lekdichte, luchtdichte kast	Vandtæt tom kasse
Serial board	Serial-Karte	Seriële kaart	Serielt kort
Sheath	Hülle	Buis	Kanal
Single-axis controller	Steuerhebel 1 achse	Seingever 1 assen	Manipulator 1 aksel

English	Deutsch	Nederlands	Danska
Single-pole toggle switch	Einpoliger schalter mit hebel	Enkelpolige Schakelaar met hendel	Enpolet vippeafbryder til
Sliding bar	Schutzgleitstange /-geländer	Schuifstang	Glidestang
Sling properties	Eigenschaften der Schlingen	Eigenschappen van de hijsbanden	Egenskaber for løftkæder
Small chain	Kette	Kettinkje	Lille kæde
Smooth male slot	Glatter bügel	Gladde intredende beugel	Afretning
Solenoid valve	Elektroventil	Elektroventiel	Elektroventil
Spacer	Unterlegkeil	Wig met dikte	Afstandsklods
Spacer plate	Blech Querstrebe	Plaat vulring	Melleplade
Spain	Spanien	Spanje	Spanien
Spare parts catalogue	Ersatzteilkatalog	Catalogus vervangonderdelen	Reservedelskatalog
Spotlight	Scheinwerfer	Projector	Projektør
Spray nozzle	Einspritzdüse	Sproeistuk	Dyse
Spring	Feder	Veer	Fjeder
Steering cylinder	Führungszylinder	Stuurcilinder	Kørselscylinder
Step	Leiter	Instap	Trinbræt
Stop	Anschlag	Aanslag	Endestop
Support	Stütze	Stut	Støtteben
Sweden	Schweden	Zweden	Sverige
Switch	Schalter	Schakelaar	Afbryder
Terminal partition block	Block Endwand	Blok eindwand	Slutvægsblok
Terrestrial interface block	Block Erdanschluss	Blok aardverbinding	Klemrække med jordforbindelse
Tilt	Neigung	Overhelling	Hældning
Tilt detector	Neigungserfassung	Detector van overhelling	Hældningsdetektor
Tooth lock washer	Zahnscheibe	Getande ring	Spændetandskive
T-piece	T-stück	Gelijke T	T-stykker
Traction battery	Zugatterie	Tractiebatteij	Batteri til kørsel
Trunking	Rinne	Gootje	Slisk
Tube	Rohr	Buis	Rør
Turn knob head	Drehschalterkopf	Kop voor draaiknop	Drejknaphoved
UK	England	Engeland	England
Union piece	Anschluß	Verbinding	Samling
Union piece	Gleichseitiges verbindungsstück	Gelijke verbinding	Lige samling
USA	USA	USA	USA
USA option	Option USA	Optioneel USA	Option USA
Variable speed unit	Verstelleinrichtung	Toerentalregelaar	Variator

English	Español	Italiano	Português
"	Etichetta "Quadro (di comando) piattaforma	« Tilt » label	Etiqueta "Inclinación"
« 110 V socket » label	Etiqueta "Toma 110V"	Etichetta "Presca 110 V"	Etiqueta "Tomada 110V"
« 115 V socket » label	Etiqueta "Toma 115V"	Etichetta "Presca 115 V"	Etiqueta "Tomada 115V"
« 230 V socket » label	Etiqueta "Toma 230V"	Etichetta "Presca 230 V"	Etiqueta "Tomada 230V"
« 240 V socket » label	Etiqueta "Toma 240V"	Etichetta "Presca 240 V"	Etiqueta "Tomada 240V"
« Anchoring hook » label	Etiqueta "Gancho anclaje"	Etichetta "Gancio ancoraggio"	Etiqueta "Gancho de fixação"
« Battery charge » label	Etiqueta "Carga batería"	Etichetta "Carica batteria"	Etiqueta "Carga bateria"
« Battery servicing » label	Etiqueta "Mantenimiento Batería"	Etichetta "Manutenzione batteria"	Etiqueta "Manutenção bate
« Bottom panel » label	Etiqueta "Pupitre bajo"	Etichetta "Quadro (di comando) basso"	Etiqueta "Painel baixo"
« Brake release » label	Etiqueta "Desfranado"	Etichetta "Sfrenatura"	Etiqueta "Destravagem"
« Direction of travel » label	Etiqueta "Sentido translación"	Etichetta "Senso traslazione"	Etiqueta "Sentido translação"
« Do not park » park	Etiqueta "No aparcas"	Etichetta "Non sostare"	Etiqueta "Não estacionar"
« Electrocutation » label	Etiqueta "Electrocución"	Etichetta "Elettrocuzione"	Etiqueta "Electrocussão"
« Floor height... » label	Etiqueta "Altura piso..."	Etichetta "Altezza pavimento..."	Etiqueta "Altura piso..."
« Platform panel » label	Etiqueta "Pupitre plataforma"	Etichetta "Quadro (di comando) piattaforma"	Etiqueta "Painel cesta"
« Hand crushing » label	Etiqueta "Aplastamiento mano"	Etichetta "Schiacciamento mani"	Etiqueta "Esmagamento mão"
« Hydraulic oil » label	Etiqueta "Aceite hidráulico"	Etichetta "Olio idraulico"	Etiqueta "Óleo Hidráulico"
« Lock spool » label	Etiqueta "Bloqueo distribuidor..."	Etichetta "Chiusura cassetto..."	Etiqueta "Bloqueio gaveta..."
« Operating instructions » label	Etiqueta "Consignas utilización"	Etichetta "Istruzioni per l'utilizzo"	Etiqueta "Instru"
« Read manual » label	Etiqueta "Leer manual"	Etichetta "Leggere il manuale"	Etiqueta "Ler manual"
« Sling load » label	Etiqueta "Carga eslinga"	Etichetta "Carica braca"	Etiqueta "Carga estropo"
« Stop lowering » label	Etiqueta "Parada bajada"	Etichetta "Arresto discesa"	Etiqueta "Paragem descida"
« Symbol summary » label	» label	Etiqueta "Recapitulativo de los símbolos"	Etichetta "Quadro (di comando) piattaforma « Tilt » label
« Tilt » label	Etiqueta "Inclinación"	Etichetta "Inclinazione"	Etiqueta "Inclinação transversal"
« Truck fork » label	Etiqueta "Horquilla carro"	Etichetta "Forca carrello"	Etiqueta "Garfo carrinho"
« Wearing of clothes » label	Etiqueta "Llevar puesta prenda..."	Etichetta "Porto di indumento..."	Etiqueta "Uso de roupa..."
« Welding earth » label	Etiqueta "Masa soldadura"	Etichetta "Massa saldatura"	Etiqueta "Massa soldadura"
«feet crushing » label	Etiqueta "Aplastamiento pies"	Etichetta "Schiacciamento piedi"	Etiqueta "Esmagamento pés"
» label	Etiqueta "Recapitulativo de los símbolos"	"	Etichetta "Quadro (di comando) piattaforma « Tilt » label
240V socket position	Etiqueta "Emplazamiento toma 240V"	Etichetta " Posizione presa 240V"	Etiqueta «Lugar tomada 240V»
Adaptor	Adaptador	Adattatore	Adaptador
Adhesive charger protection	Protección cargador adhesiva	Protezione caricatore adesiva	Protecção do carregador autocolan
Adjustment washer	Arandela de ajuste	Rondella per la regolazione	Anel de regulação

English	Español	Italiano	Português
Anti-tipping over device	Dispositivo anti-vuelco	Dispositivo antiribaltamento	Dispositivo anti-basculamento
Australia	Australia	Australia	Austrália
Auxiliary contact	Contacto auxiliar	Contatto ausiliare	Contacto auxiliar
Bag of seals	Bolsita de juntas	Bustina di giunti	Embalagem de juntas
Ball	Bola	Palla	Esfera
Barrier handrail	Barra barandilla	Listone parapetto	Corrimão do anteparo
Base	Asiento	Collare	Colar
Base	Zócalo	Zoccolo	Base
Battery box	Caja baterías	Cassa batterie	Caixa de bateria
Battery charger	Cargador de batería	Caricatore de batteria	Carregador de bateria
Battery cut-off	Cortador de batería	Spaccato batteria	Interruptor de bateria
Battery strap	Correa batería	Cinghia batteria	Correia bateria
Battery unit	Conjunto batería	Insieme batteria	Conjunto bateria
Bearing plate	Placa de apoyo	Piastra di appoggio	Placa de apoio
Bend	Codo	Gomito	Joelho
Biodegradable oil	Aceite biodegradable	Olio biodegradabile	Óleo biodegradável
Bi-voltage charger	Cargador bitensión	Caricatore doppia tensione	Carregador bi-tensão
Bonding jumper	Trenza de masa	Treccia di massa	Cabo trançado de ligação à massa
Bottom part	Parte baja	Parte bassa	Parte baixa
Box	Caja	Scatola	Caixa
Brace	Distanciador	Distanziatore	Espaçador
Braid (not felt)	Cinta sin fieltro	Gallone non feltro	Trança não feltrada
Brake	Freno	Freno	Travão
Bundle	Haz	Fascio	Feixe
Buzzer	Avisador	Avvisatore	Buzina
Cable	Cable	Cavo	Cabo
Cable clip	Abrazadera de fijación	Collare di fissaggio	Braçadeira de fixação
Cable support	Soporte cable	Supporto cavo	Suporte do cabo
Cables	Cableado	Cablaggio	Cablagem
Caliper	Estribo	Staffa	Grampo
Cam	Leva	Camme	Came
Can	Bidón	Bidone	Bidão
Canada	Canadá	Canada	Canadá
Central hydraulic plant	Central hidráulica	Centrale idraulica	Central hidráulica
Centralised filling	Rellenado centralizado	Riempimento centralizzato	Enchimento centralizado

English	Español	Italiano	Português
Centralised filling kit	Kit de rellenado centralizado	Kit riempimento centralizzato	Kit de enchimento centralizado
charger	Cargador	Carica batterie	Carregador
Charger connection	Conexión cargador	Raccordo caricatore	Junção carregador
Chassis cover	Capó del chasis	Cofano telaio	Cobertura do chassis
Chock	Calce	Spessore	Calço
Circlips	Circlips	Circlips	Freio de retenção
Collar	Collar	Collare	Braçadeira
Common labels	Etiquetas Comunes	Etichette comuni	Etiquetas comuns
Connecting bar	Barra de enlace	Barra di collegamento	Barra de ligação
Contact block	Cuerpo completo	Corpo completo	Corpo completo
Control block	Bloque de regulación	Blocco di regolazione	Bloco de regulação
Control box	Caja de mando	Modulo comando	Caixa de comando
Control panel unit	Conjunto pupitre	Insieme consolle	Conjunto mesa
Cylinder axis	Eje de gato	Asse di martinetto	Eixo de cilindro
Denmark	Dinamarca	Danimarca	Dinamarca
Differential circuit breaker	Disyuntor diferencial	Interruttore differenziale	Disjuntor diferencial
Direction lever	Palanca de dirección	Leva di direzione	Alavanca de direcção
Direction pivot	Pivote de dirección	Perno di direzione	Cavilhão de direcção
Distribution block	Bloque de distribución	Blocco di distribuzione	Bloco de distribuição
Document box	Caja de documentos	Scatola documenti	Caixa de documentos
Double hose clamp	Brida doble de apriete	Anello doppio per serraggio	Anel duplo aperto
Double-pole toggle switch	Interruptor bipolar de palanca	Interruttore bipolare a leva	Interruptor bipolar de alavanca
Drilling diagram	Plan de perforación	Piano foratura	Plano de perfuração
Dry battery	Batería seca	Batteria secca	Bateria seca
Electric diagram	Esquema electrico	Schema elettrico	Esquema eléctrico
Electric socket on platform label	Etiqueta "Toma de corriente en plataforma"	Etichetta "Presa elettrica sulla piattaforma"	Electrical component kit
Electrical component kit	Kit componente eléctrico	Kit componente elettrico	Kit componente eléctrico
Electricity	Electricidad	Elettricità'	Electricidade
Electropump	Electrobomba	Elettropompa	Electro-bomba
Emergency control	Mando de socorro	Comando di riserva	Comando de emergência
Emergency stop	Parada de emergencia	Arresto di emergenza	Paragem de emergência
End fitting	Extremo	Elemento terminale	Ponteira
End of travel	Fin de carrera elevacion	Fine corsa sollevamento	Fim de curso levantamento
Equal T-piece	Te igual	Te uguale	Tê igual
Explosion risk label	Etiqueta "Peligro de explosión"	etichetta "Rischio di esplosione"	Etiqueta "Risco de explosão"

English	Español	Italiano	Português
Extension rod	Bielita de extensión	Bielletta estensione	Biela extensão
Extension roller pin	Eje rodillo de extensión	Asse rullo estensione	Eixo rodízio extensão
Exterior arm	Brazo exterior	Braccio esterno	Braço exterior
Exterior right arm	Brazo exterior derecho	Braccio esterno destro	Braço exterior direito
Extract	Extracto	Estratto	Extraído
Fastener	Grapa	Agrafe	Agrafo
Filter	Filtro	Filtro	Filtro
Finland	Finlandia	Finlandia	Finlândia
Flange	Brida	Flangia	Flange
Flanging tab	Pata de bridaje	Patta di raccordo	Gancho de refreamento
Flashing light	Luz de destellos	Fanale a bagliore	Luz intermitente
Flat washer	Arandela plana	Rondella piatta	Anilha plana
Flexible	Flexible	Flessibile	Tubo flexível
Floater	Flotador	Galleggiante	Flutuador
Floor height + load label	Etiqueta altura piso + Carga	etichetta altezza pianale + carico	Etiqueta altura pavimento + C
Flooring extension	Extensión suelo	Estensione piattaforma	Extensão piso
Flow indicator	Indicador de flujo	Indicatore di flusso	Indicador de fluxo
Flush-fitting socket	Enchufe encastrado	Presa a incasso	Tomada ajustável
Foam	Espuma	Schiuma	Espuma
Frame	Chasis	Telaio	Chassis
Frame cowling	Capotaje chasis	Capottatura telaio	Invólucro chassis
France	Francia	Francia	França
Fuse	Fusible	Fusibile	Fusível
Fuse holder	Portafusible	Portafusibile	Porta-fusível
Germany	Alemania	Germania	Alemanha
Grease point	Engrasador	Ingrassatore	Lubrificador
Grease point cover	Tapa engrasador	Maschera lubrificatore	Tampa-lubrificador
Green indicator light	Piloto verde	Spia verde	Luz avisadora verde
Guardrail	Antepechos	Ringhiera	Parapeito
High Speed cut-off	Corte velocidad alta	Interruzione Grande Velocità	Corte Grande Velocidade
Holder	Soporte	Supporto	Suporte
hood	Capó	Coperchio	Capô
Hydraulic diagram	Esquema hidraulico	Schema idraulico	Esquema hidráulico
Hydraulic installation	Instalacion hidraulica	Impianto idraulico	Instalação hidráulica
Hydraulic motor	Motor hidráulico	Motore idraulico	Motor hidráulico

English	Español	Italiano	Português
Hydraulic reservoir assembly	Unidad de depósito hidráulico	Insieme serbatoio idraulico	Conjunto depósito hidráulico
Indicator	Indicador	Indicatore	Indicador
Interior arm	Brazo interior	Braccio interno	Braço interior
Intermediate guardrail	Barandilla intermedia	Corrimano intermedio	Balaustrada intermediária
Italy	Italia	Italia	Italia
Key	Chaveta	Chiavetta	Chaveta
Knurled screw	Tornillo moleteado	Vite zigrinata	Parafuso estriado
Label	Etiqueta	Etichetta	Etiqueta
Labels	Etiquetas	Etichettas	Etiquetas
Lamp	Lámpara	Lampada	Lâmpada
Latch	Pestillo	Levetta di chiusura	Trinco
Left anti-tipping over device	Dispositivo anti-vuelco izquierdo	Dispositivo antiribaltamento sinistro	Dispositivo anti-b
Left guardrail	Barandilla izquierda	Corrimano sinistro	Balaustrada esquerda
Left hood	Capó izquierdo	Cofano sinistro	Capô esquerdo
Left link	Bielita izquierda	Bielletta sinistra	Tirante esquerda
Left pivot	Pivote izquierdo	Perno sinistra	Cavilhão esquerdo
lift cylinder	Gato elevación	Martinetto solle	Cilindro de elevação
Link rod	Bielita	Bielletta	Tirante
LIXXBAIL label	Etiqueta "LIXXBAIL"	Etichetta "LIXXBAIL"	Etiqueta "LIXXBAIL"
Load capacity label	Etiqueta "Capacidad de carga"	Etichetta "Capacità di carico"	Etiqueta «Capacidade de carga»
load capacity sticker	Pegatina "Capacidad de carga"	Adesivo "Capacità di carico..."	Autocolante "Capacidade de carga"
Lobe wheel	Volante lobulado	Volante a lobi	Volante com ressaltos
Lock	Husillo	Punzone	Pino
Lock nut	Contratuerca	Controdado	Contra-porca
Lock nut	Tuerca de freno	Dado freno	Porca travão
Locking pin	Eje cerrojo	Asse catenaccio	Eixo fecho
Logo	Grafismo	Grafica	Grafismo
Lug	Terminale	Teste	Terminal
Male union piece	Uniónmacho	Unione maschio	União macho
Manual	Manual	Guida	Manual
Manual of responsibilities	Manual de responsabilidades	Guida alla responsabilità	Manual de responsabilidades
Manufacturer's name plate	Placa constructor	Targa costruttore	Placa construtor
Minimess tap	Toma minimess	Presca minimess	Tomada Minimess
Motor guiding axle	Eje motodirector	Asse motore-sterzante	Eixo motorizado de direcção
Mushroom-headed button	Botón interruptor de bola	Pulsante a fungo	Botão de emergência

English	Español	Italiano	Português
Netherlands	Holanda	Olanda	Holanda
Non-slip adhesive tape	Adhesivo antideslizante	Adesivo antiscivolo	Adesivo anti-derrapante
Nut	Tuerca	Dado	Porca
Oil filter	Filtro de aceite	Filtro olio	Filtro de óleo
Operating station extension	Alargadera en puesto de conducción	Prolunga posto di guida	Extensão no posto de condução
Operator's manual	Manual de operación y mantenimiento	Manuale de guida e manutenzione	Manual CE
Operator's manual	Manual del operador	Guida dell'operatore	Manual do operador
Option	Opción	Opzione	Opção
Organic oil	Aceite biológico	Olio biologico	Óleo biológico
O-ring	Junta tórica	Giunto torico	Junta tórica
Owner's manual	Manual del usuario	Guida utente	Owner's Manual
Packing box	Prensaestopas	Premistoppa	Empanque
Pad	Patín	Pattino	Patim
Pedal	Pedal	Pedale	Pedal
Permitted load label	Etiqueta "Carga admisible"	Etichetta "Carico autorizzato"	Etiqueta "Carga permitida"
Pin	Eje	Asse	Eixo
Pin	Pasador	Bietta	Cavilha
Pipe	Tubo	Tubo	Tubo
Plate	Chapa	Lamiera	Chapa
Plate mounting unit	Conjunto montaje platillo	Insieme montaggio piastra	Conjunto montagem platina
Platform	Plataforma de barquilla	Cestello piattaforma	Plataforma
Platform	Plataforma	Piattaforma	Plataforma
Platform control box	Caja plataforma	Cofanetto piattaforma	Caixa cesta
Platform safety barrier	Barandilla de plataforma	Parapetto piattaforma	Anteparo plataforma
Platform supply	Alimentación en plataforma	Alimentazione su piattaforma	Alimentação na plataforma
Platform with foldable guard rail	Plataforma con antepechos abatible	Piattaforma con ringhiera abbassabile	Plataforma c
Plug	Clavija	Spina	Ficha
Plug	Tapón obturador	Tappo otturatore	Bujão obstruidor
Plug	Tapón	Tappo	Bujão
Plug socket	Toma	Presca	Tomada
Portugal	Portugal	Portogallo	Portugal
Position switch	Interruptor de posición	Interruttore di posizione	Interruptor de posição
Pothole cylinder	Gato de bache	Martinetto di pothole	Macaco pothole
Pressure controller	Manocontacto	Contattore manometrico	Manocontacto
Printed circuit	Circuito impreso	Circuito stampato	Circuito impresso

English	Español	Italiano	Português
Protective cover	Tapa de protección	Cofano di protezione	Cobertura de protecção
Protective plate	Placa de protección	Piastra di protezione	Placa de protecção
Rail	Barra	Listone	Corrimão
Rapid fastener	Empalme rápido	Raccordo rapido	Junção rápida
Rear axle	Eje trasero	Asse posteriore	Eixo traseiro
Red light indicator	Piloto rojo	Spia rossa	Sinal luminoso vermelho
Reducer	Reductor	Riduttore	Redutor
Relay	Relé	Relè	Relé
Remote control	Mando a distancia	Comando a distanza	Comando remoto
Repair manual	Manual de reparaciones	Manuale di manutenzione	Repair manual
Retaining bracket	Pate de fijación	Braccio di fissaggio	Patilha de fixação
Right anti-tipping over device	Dispositivo anti-vuelco derecho	Dispositivo antiribaltamento destro	Dispositivo anti-basc
Right guardrail	Barandilla derecha	Corrimano destro	Balaustrada direita
Right hood	Capó derecho	Cofano destro	Capô direito
Right link	Bielita derecha	Bielletta destra	Tirante direita
Ring	Anillo	Anello	Casquilho
Rivet	Remache	Chiodo	Rebite
Roller	Rodillo	Rullo	Rolete
Rotary knob with key	Botón giratorio de llave	Manopola girevole con chiave	Botão rotativo de chave
Rubber ring	Anillo elástico	Anello elastico	Anilha de freio
Rubber washer	Arandela elástica	Rondella elastica	Anilha elástica
Safety manual	Manual de seguridad	Guida alla sicurezza	Manual de secorro
Safety support	Escuadra de seguridad	Squadra di sicurezza	Esquadro de segurança
Scissor lift platform unit	Conjunto tijeras	Insieme forbici	Conjunto tesouras
Screw	Tornillo	Vite	Parafuso
Seal	Junta	Giunto	Junta
Seal	Obturador	Otturatore	Obturador
Sealed batteries	Baterías estancas	Batterie a tenuta stagna	Baterias estanques
Sealed battery charger	Cargador de batería estanco	Caricatore di batteria a tenuta stagna	Carregador de bateria estanque
Sealed empty box	Caja vacía estanca	Scatola vuota impermeabile	Caixa vazia vedada
Serial board	Tarjeta Serial	Carta Serial	Carta Serial
Sheath	Conducto	Rivestimento	Manga
Single-axis controller	Manipulador 1 eje	Manipolatore 1 asse	Manipulador 1 eixo
Single-pole toggle switch	Interruptor unipolar de palanca	Interruttore unipolare a leva	Interruptor unipolar de alavanca
Sliding bar	Barra deslizante	Sbarra scorrevole	Barra escorregadiça

English	Español	Italiano	Português
Sling properties	Características de las eslingas	Caratteristiche delle imbracature	Características das correntes
Small chain	Cadenita	Catenella	Pequena corrente
Smooth male slot	Horquilla macho lisa	Forcella maschio liscia	Forquilha macho lisa
Solenoid valve	Electroválvula	Elettrovalvola	Electroválvula
Spacer	Calce grosor	Zeppa spessore	Calço espessura
Spacer plate	Chapa traviesa	Lamiera distanziatore	Chapa escora
Spain	España	Spagna	Espanha
Spare parts catalogue	Catálogo PR	Catalogo PR	Catálogo peças sobresselentes
Spotlight	Proyector	Proiettore	Farol
Spray nozzle	Surtidor	Ugello	Pulverizador
Spring	Resorte	Molla	Mola
Steering cylinder	Gato de dirección	Martinetto di direzione	Cilindro de direcção
Step	Peldaño	Pedana	Degrau
Stop	Tope	Arresto	Batente
Support	Patin	Maniglia	Suporte
Sweden	Suecia	Svezia	Suécia
Switch	Interruptor	Interruttore	Interruptor
Terminal partition block	Bloque pared terminal	Blocco tramezzo terminale	Bloco parede terminal
Terrestrial interface block	Bloque empalme de tierra	Blocco giunzione di terra	Bloco de junção de terra
Tilt	Inclinación	Inclinazione	Inclinação transversal
Tilt detector	Detector de inclinación	Rivelatore di inclinazione	Detector de inclinação transversal
Tooth lock washer	Arandela de dientes	Rondella a dente	Anilha de dentes
T-piece	Te	Te	Tê
Traction battery	Batería de tracción	Batteria di trazione	Bateria de tracção
Trunking	Conducto	Bocchettone	Calha
Tube	Tubo	Tubo	Tubo
Turn knob head	Cabeza de botón giratorio	Testa di manopola girevole	Cabeça de botão rotativo
UK	Inglaterra	Inghilterra	Inglaterra
Union piece	Unión igual	Unione uguale	União em Tê
Union piece	Unión	Unione	União
USA	Estados-Unidos	USA	Estados Unidos
USA option	Opción EE.UU	Opzione USA	Opção USA
Variable speed unit	Variador	Variatore	Variador
Voltage label	Etiqueta "Tensión"	etichetta "Voltaggio"	Etiqueta "Voltagem"
Warranty activation label	Etiqueta "Activación garantía"	Etichetta "Inizio garanzia "	Etiqueta «Accionamento garantido»

English	Svenska	Suomi	Română
« 110 V socket » label	Etikett "110V uttag"	Etiketti "Pistoke 110V"	Eticheta "Priza 110V"
« 115 V socket » label	Etikett "115V uttag"	Etiketti "Pistoke 115V"	Eticheta "Priza 115V"
« 230 V socket » label	Etikett "230V uttag"	Etiketti "Pistoke 230V"	Eticheta "Priza 230V"
« 240 V socket » label	Etikett "240V uttag"	Etiketti "Pistoke 240V"	Eticheta "Priza 240V"
« Anchoring hook » label	Etikett "Förankringskrok"	Etiketti "Kiinnityshaka"	Eticheta "Carlig de tractare"
« Battery charge » label	Etikett "Batteriladdning"	Etiketti "Pariston lataus"	Eticheta "Incarcare baterie"
« Battery servicing » label	Etikett "Underhåll av batteriet"	Etiketti "Pariston huolto"	Eticheta "Intretinere baterie"
« Bottom panel » label	Etikett "Manöverpanel nere"	Etiketti "Alakonsoli"	Eticheta "Pupitru de jos"
« Brake release » label	Etikett "Avbromsning"	Etiketti "Jarrutus"	Eticheta "Defranare"
« Direction of travel » label	Etikett "Körriktning"	Etiketti "Kuljetuksen suunta"	Eticheta "Sens translatie"
« Do not park » park	Etikett "Parkering förbjuden"	Etiketti "Älä pysäköi"	Eticheta "A nu stationa"
« Electrocutation » label	Etikett "Elstöt"	Etiketti "Sähköiskuvaara"	Eticheta "Pericol de electrocutare"
« Floor height... » label	Etikett "Golvhöjd..."	Etiketti "Pohjan korkeus..."	Eticheta "Planseu inalt"
« Platform panel » label	Etikett "Manöverpanel i plattformen"	Etiketti "Moottorikehilon konsoli"	Eticheta "Pupitru nacela"
« Hand crushing » label	Etikett "Sönderklämning av hand"	Etiketti "Käsi voi jäädä puristuksiin"	Eticheta "Pericol de ran"
« Hydraulic oil » label	Etikett "Hydraulolja"	Etiketti "hydrauliikkaöljy"	Eticheta "Ulei Hidraulic"
« Lock spool » label	Etikett "Låsning av låda..."	Etiketti "Laatikon lukitus..."	Eticheta "Blocrare sertar..."
« Operating instructions » label	Etikett "Instruktioner för användning"	Etiketti "Käyttöohjeet"	Eticheta "Dispozitii de"
« Read manual » label	Etikett "Läs handboken"	Etiketti "Lue ohjekirja"	Eticheta "A citi manualul"
« Sling load » label	Etikett "Slingbelastning"	Etiketti "Nostosilmukan asetus"	Eticheta "Cablu de incarcare"
« Stop lowering » label	Etikett "Stopp av nedsänkning"	Etiketti "Laskun pysäytys"	Eticheta "Oprire coborare"
« Symbol summary » label	» label	Etikett "Sammanställning av symboler"	Etiketti "Symbolien yhteenveto"
« Tilt » label	Etikett "Lutning"	Etiketti "Kaltevuus"	Eticheta "Inclinare"
« Truck fork » label	Etikett "Truckgaffel"	Etiketti "Haarukkakuljetin"	Eticheta "Furca de tractare"
« Wearing of clothes » label	Etikett "Användning av kläder ..."	Etiketti "Asusteiden käyttö..."	Eticheta "Port de echip"
« Welding earth » label	Etikett "Svetsningsjord"	Etiketti "Maadoitus (hitsaus)"	Eticheta "Masa sudura"
« feet crushing » label	Etikett "Sönderklämning av fötter"	Etiketti "Jalka voi jäädä puristuksiin"	Eticheta "Pericol de"
» label	Etikett "Sammanställning av symboler"	Etiketti "Symbolien yhteenveto"	
240V socket position	Dekal "Placering av 240V-uttag"	Tarra "240V:n pistokkeen sijainti"	Eticheta "Amplasare priza 240 V"

English	Svenska	Suomi	Română
Adaptor	Adapter	Naarasadapteri	Adaptor
Adhesive charger protection	Självvidhäftande laddarskydd	Luonnonsuojelu kasetti itse - kiinni pysyvä	
Adjustment washer	Reglerbricka	Säätöaluslaatta	
Anti-tipping over device	Fördjupning	Pothole	Suport stabilizator
Australia	Australien	Australia	Australia
Auxiliary contact	Hjälpkontakt	Lisäkosketin	Contact auxiliar
Bag of seals	Påse med packningar	Tiivistekotelo	Locas de garnituri
Ball	Kula	Pallo	Bila bula
Barrier handrail	Ledstång på skyddsräcke	Turvakaiteet	Lonjeron de protectie
Base	Sockel	Kehys	Placa de baza
Base	Sockel	Pistorasia	Soclu
Battery box	Batterilåda	Paristokotelo	Cheson de baterie
Battery charger	Batteriladdare	Pariston lataaja	Incarcator de acumulator / baterie
Battery cut-off	Batteribrytare	Pariston virrankatkaisu	Sectiune baterie
Battery strap	Batterirem	Paristohihna	Chinga baterie
Battery unit	Batterienhet	Akkukokonaisuus	
Bearing plate	Stödplatta	Tukilaatta	Placa de sprijin
Bend	Knärör	Taive	Cot
Biodegradable oil	Biologiskt nedbrytbar olja	Biologisesti hajoava öljy	Ulei biodegradabil
Bi-voltage charger	Tvåspänningsladdare	Kaksoisvirta laturi	Incarcator bi-tensiune
Bonding jumper	Jordomflätning	Maadoitusvahvike	Banda de masa
Bottom part	Nedre del	Alaosa	Partea de jos
Box	Dosa	Kotelo	Cutie
Box	Låda	Asia	Carcasa cutie
Brace	Mellanlägg	Välituki	Antretuaza
Braid (not felt)	Kantband utan filtyg	Huovittamaton reunus	Galon neintarit (fara pasla)
Brake	Broms	Jarrut	Frina
Bundle	Kabelhärva	Keila	Fascicul
Buzzer	Signalhorn	Merkinantolaitte	Avertizor semnalizator
Cable	Kabel	Vaijeri	Cablu
Cable clip	Fastsättningsklämman	Letkunkiinnitin	Colier de fixare
Cable support	Kabelfäste	Kannatin kaapeloida	
Cables	Kabelföring	Kyt kentä	Cablare
Caliper	Bygel	Haka	Etrier
Cam	Kam	Nostovarsi	Cama

English	Svenska	Suomi	Română
Can	Dunk	Bidon	Bidon
Canada	Canada	Kanada	
Central hydraulic plant	Hydrulbehållare	Hydrauliikkakeskus	Centrala hidraulica
Centralised filling	Centralstyrd påfyllning	Laverrella käteinen arvo	
Centralised filling kit	Utrustning för centralstyrd påfyllning	Pakkaus laverrella käteinen arvo	
charger	Laddare	Laturi	
Charger connection	Laddaranslutning	Laturiliitos	Racord încarcator
Chassis cover	Chassihuv	Naisen lakki alusta	
Chock	Kil	Kiila	Cala
Circlips	Fjädderring	Lukkorengas	Inel de blocare elastic
Collar	Klamma	Kiinnitin	Banda bratară colier
Common labels	Gemensamma dekaler	Etiketti alhainen	
Connecting bar	Förbindelsestång	KytKentäkisko	Bara de legatura
Contact block	Hel huvuddel	Koko runko	Corp complet
Control block	Reglerblock	Säätöpesä	Bloc regulator
Control box	Styrlåda	Käskylaatikko	Tablou de comanda
Control panel unit	Manöverpanelenshet	Ohjauspöytäkokonaisuus	
Cylinder axis	Domkraftsaxel	Sylinteriakseli	Ax de cric
Denmark	Danmark	Tanska	Danemarca
Differential circuit breaker	Jordfelsbrytare	Differentiaalikatkaisin	Disjuncto (intreruptor) diferential
Direction lever	Pitmanarm	Ohjausvipu	Levier de directie
Direction pivot	Styrbult	Ohjaustappi	Pivot de directie
Distribution block	Fördelningenshet	Jakelulohko	Bloc de distributie
Document box	Dokumenthållare	Asiakirjalaatikko	Cutie pentru documente
Double hose clamp	Dubbel slangklämna	Kaksinkertainen letkunkiristin	
Double-pole toggle switch	Tvåpolig strömbrytare med spak	Kaksinapainen vipukytkin	Intreruptor bipolar la levier
Drilling diagram	Håltagningschema	Porauspiirustus	proiect de gaurire
Dry battery	Torrt batteri	Kuivapariisto	
Electric diagram	Kopplingsschema	Sähkökaavio	Schema electrica
Electric socket on platform label	Dekal "Eluttag på plattformen"	Näyttää ajaksi sähkö jokseenkin plateforme	
Electrical component kit	Elektrisk komponentsats	Sähkökomponenttisarja	
Electricity	Elektricitet	Sähkö	Electricitate
Electropump	Elektrisk pump	Sähköpumppu	Electro-pompa
Emergency control	Hjälpreglage	Hätäohjaus	Comanda

English	Svenska	Suomi	Română
Emergency stop	Nödstopp	Hätäpysäytys	Oprire de urgenta
End fitting	Ändstycke	Istukka	Racord special sabot
End of travel	Lyftningsgränsläge	Noston lopetus	Sfirsit de cursa ridicare
Equal T-piece	Jämn T-koppling	Samanarvoinen T-kappale	Te egal
Explosion risk label	Dekal "Explosionsrisk"	Etiketti "Räjähdysvaara"	
Extension rod	Draglänk utskjut	Tankolaajennus	Bieleta de extensie
Extension roller pin	Axel utsträckningsrulle	Telalaajennus akseli	Axa disc de extensie
Exterior arm	Ytterarm	Ulkopuomi	Brat exterior
Exterior right arm	Höger ytterarm	Oikea ulkopuomi	Brat exterior dreapta
Extract	Utdrag	Ote	
Fastener	Fästdon	Hakanen	Agrafa, clama, scoaba
Filter	Filter	Suodatin	Filtru
Finland	Finland	Suomi	Finlanda
Flange	Fläns	Pidike	Brida flansa clama
Flanging tab	Flänsbeslag	Kiinnityskoukku	Cârlig împerechere
Flashing light	Blinkljus	Vilkkuvalo	Semnal luminos
Flat washer	Flat bricka	Lititeä laatta	Saiba plata
Flexible	Slang	Letku	Flexibil
Floater	Flottör	Ajelehtia	
Floor height + load label	Dekal, golvhöjd + last	Etiketti Pohjan korkeus + Kuorma	
Flooring extension	Golvutvidgning	Kannen jatkos	Extensie platforma
Flow indicator	Flödesindikator	Ilmaisoin jokseenkin aaltoilu	
Flush-fitting socket	Infällbart uttag	Upotettava pistoke	Priza încastrabila
Foam	Skumplast	Vahto	Spuma
Frame	Chassi	Runko	Rama sasiu cadru
Frame cowling	Huv för chassi	Rungon suojakotelo	Rasturnare sasiuri
France	Frankrike	Ranska	Franta
Fuse	Säkring	Sulake	Fuzibil
Fuse holder	Säkringshållare	Sulakkeen pidike	Port-fuzibil
Germany	Tyskland	Saksa	German
Grease point	Smörjnippel	Voitelija	Ungator
Grease point cover	Lock för fettnippel	Voitelijan suojus	Panou ungator
Green indicator light	Grön kontrollampa	Vihreä merkkivalo	Bec de semnalizare verde
Guardrail	Räcke	Suojakaide	Balustrada
High Speed cut-off	Avstängning hög hastighet	Suuren nopeuden virrankatkaisu	Taietura G.V.
Holder	Fäste	Tuki	Suport

English	Svenska	Suomi	Română
hood	Huv	Kansi	Capota, carcasa
Hydraulic diagram	Hydrauliskt schema	Hydrauliikkakaavio	Schema hidraulica
Hydraulic installation	Hydraulisk installation	Hydrauliikka-asennus	Instalatie hidraulica
Hydraulic motor	Hydraulisk motor	Hydraulinen moottori	Motor hidraulic
Hydraulic reservoir assembly	Hydraulbehållare	Hydrauliikkasäiliöt	Ansamblu rezervor hidraulic
Indicator	Indikator	Osoitin	Indicator
Interior arm	Innerarm	Alapuomi	Brat interior
Intermediate guardrail	Mellanskyddsräcke	Välisuojaikaide	Balustrada intermediara
Italy	Italien	Italia	Italia
Key	Kil	Hapsichord	
Knurled screw	Räfflad skruv	Pykäläruuvi	Surub pentru cutit-disc/ randalinapentru zimtat
Label	Etikett	Etiketti	Eticheta
Labels	Etiketter		Etichete
Lamp	Lampa	Lamppu	Lampa
Latch	Tät	Salpa	Zavor
Left anti-tipping over device	Vänster fördjupning	Vasen pothole	Suport stabilizator stanga
Left guardrail	Vänster skyddsräcke	Vasen suojakaide	Balustrada stanga
Left hood	Huv vänster	Vasen kansi	Capota stanga
Left link	Vänster stag	Vasen tanko	Bieleta stanga
Left pivot	Vänster spindelhus	Vasen tappi	Pivot stanga
lift cylinder	Domkraft för lyftning	Nostosylinteri	Cric de ridicare
Link rod	Stag	Tanko	Bieleta
LIXXBAIL label	Etikett "LIXXBAIL"	LIXXBAIL tarra	Eticheta "LIXXBAIL"
Load capacity label	Dekal "Lastkapacitet"	Tarra "Latausteho"	Eticheta "Capacitate de incarcare"
load capacity sticker	Självhäftande dekal "Lastkapacitet..."	Tarra "Kantokyky..."	
Lobe wheel	Svånghjul med flikar	Keiloilla varustettu pyörä	Partea de lucru a volantului
Lock	Spindel	Kara	Brosa
Lock nut	Låsmutter	Jarrumutteri	Piulita de franare/contrapiulita
Lock nut	Låsmutter	Lukitusmutteri	Contra-piulita
Locking pin	Låsets axel	Lukkoakseli	Axa lacat
Logo	Grafisk framställning	Graafinen	Grafic
Lug	Kabelskor	Liitin	Lama de racord, papuc de cablu, ureche
Male union piece	Anslutning av hantyp	Urosliitos	Legatura

English	Svenska	Suomi	Română
Manual	Handbok	Ohjekirja	Manual
Manual of responsibilities	Handbok för ansvarsområden	Vastuuohekirja (Manual of responsibilities)	
Manufacturer's name plate	Tillverkarskylt	Rakennuslaatta	Placa de baza/constructoare
Minimess tap	Minimess-uttag	Minimess-otto	Priza Minimess
Motor guiding axle	Driv- och styraxel	Vetoakseli	Osie moto-conducatoare
Mushroom-headed button	Handtryckknapp	Hätäpainike	Buton de pornire
Netherlands	Holland	Hollanti	Olanda
Non-slip adhesive tape	Slirfri tejp	Liukuestetarra	Adeziv antiderapant
Nut	Mutter	Mutteri	Piulita
Oil filter	Oljefilter	Öljynsuodatin	Filtru de ulei
Operating station extension	Förlängningssladd till förarplats	Ala lyijynen jokseenkin lähettää postissa ...	
Operator's manual	EG-manual	Käsikirja CE	Manual CE
Operator's manual	Användarhandbok	Käyttäjän ohjekirja (Operator's manual)	
Option	Tillval	Vaihtoehto	Optiune
Organic oil	Biologisk olja	Hiilestää biologinen	
O-ring	O-ring	O-rengastiiviste	Manseta de rotatie
Owner's manual	Agarens manual	Omistajan ohjekirja	Ghidul utilizatorului
Packing box	Packbox	Hidastin	Presare garnitura
Pad	Glidyta	Luistin	Patina
Pedal	Pedal	Poljin	Pedala
Permitted load label	Etikett "Tillåten last"	Kuorma sallittu tarra	Eticheta Sarcina admisibila
Pin	Axel	Akseli	Ax
Pin	Sprint	Sokka	Opritor, stut de siguranta
Pipe	Rör	Putki	Teava, conducta
Plate	Plåt	Pelti	Tola/tabla
Plate mounting unit	Ensemble montage platine	Platina-kytkentäkokonaisuus	
Platform	Korgplattform	Korin lava	Platforma nacelei
Platform	Plattform	Alusta	Platforma
Platform control box	Kopplingsdosa för plattform	Kehilökotelo	Cutie nacela
Platform safety barrier	Skyddsräcken på plattform	Lavan kaide	
Platform supply	Matning på plattform	Syöttö kuormauslavalla	Alimentare pe platforma
Platform with foldable guard rail	Plattform med nedfällbart räcke	Alasvedettävällä kaiteella varustettu alusta	Platform

English	Svenska	Suomi	Română
Plug	Plugg	Tulppa	Dop, capac insurubat, buson
Plug	Stickkontakt	Pistoke	Fisa
Plug	Tillslutningsplugg	Korkita ikkunaluukku	
Plug socket	Uttag	Otto	Priza
Portugal	Portugal	Portugali	Portugalia
Position switch	Lägesbrytare	Asemointikytkin	Intrerupator de pozitie
Pothole cylinder	Stödsystemscylinder	Kuoppasylinteri	Cric de
Pressure controller	Tryckkontakt	Kosketin	Manocontact
Printed circuit	Tryckt krets	Painopiiri	Circuit imprimat
Protective cover	Skyddskåpa	Naisen lakki jokseenkin luonnonsuojelu	
Protective plate	Skyddsplåt	Suojaalaatta	Placa de protectie
Rail	Ledstång	Kaide	Lonjeron
Rapid fastener	Snabbkoppling	Pikaliitin	
Rear axle	Bakaxel	Taka-akseli	Osie spate
Red light indicator	Röd kontrollampa	Merkkivalo punainen	Bec de semnalizare rosu
Reducer	Reducerväxel	Hidastin	Reductor
Relay	Relä	Rele	Releu
Remote control	Fjärrstyrning	Kauko-ohjaus	Comanda la distanta
Repair manual	Reparationshandbok	Manuaalinen korjaus	Manual de reparatii
Retaining bracket	Fästkrampa	Kiinnityshaka	Suport de fixare
Right anti-tipping over device	Höger fördjupning	Oikea pothole	Suport stabilizator dreapta
Right guardrail	Höger skyddsräcke	Oikea suojakaide	Balustrada dreapta
Right hood	Huv höger	Oikea kansi	Capota dreapta
Right link	Höger stag	Oikea tanko	Bieleta dreapta
Ring	Ring	Rengas	Bucsa
Rivet	Nit	Niitti	Nit
Roller	Rulle	Tela	Rola
Rotary knob with key	Vridknapp med nyckel	Avaimella varustettu kiertonappi	Buton rotativ cu cheie
Rubber ring	Kluven konisk bussning	Joustorengas	Inel elastic
Rubber washer	Fjäderbricka	Joustolaatta	Saiba elastica
Safety manual	Säkerhetshandbok	Turvallisuusohjekirja (Safety manual)	
Safety support	Säkerhetshörnjärn	Turvakiinnitys	Echer de siguranta
Scissor lift platform unit	Saxenhet	Leikkurit	Ansamblu foarfece
Screw	Skruv	Ruuvi	Surub

English	Svenska	Suomi	Română
Seal	Packning	Tiiviste	Garnitura
Seal	Täckplåt	Suljin	Obturator
Sealed batteries	Täta batterier	Tiiviit paristot	Baterii etansate
Sealed battery charger	Laddare av tätt batteri	Tiiviin pariston lataaja	Incarcator de baterie etans
Sealed empty box	Vattentät tom låda	Tiivis tyhjä kotelo	Cutie goala inchisa etans
Serial board	Seriekort	Sarjakortti	Harta Serial
Sheath	Kanal	Vaippa	Canal
Single-axis controller	Manipulator 1 axel	Kytkin 1 akseli	Manipulator 1 axa
Single-pole toggle switch	Interrupteur unipolaire à med spak	Vivulla varustettu yksinapainen kytkin	Intrerupator unipola
Sliding bar	Skjutbar stång	Luistintanko	
Sling properties	Slingornas karakteristika	Nostosilmukoiden ominaisuudet	Caracteristicile cablurilor de tractiune
Small chain	Liten kedja	Pieni ketju	Lantisor
Smooth male slot	Slät ytterkåpa	Sileä urossuojus	Placa neted
Solenoid valve	Magnetventil	Sähköventtiili	Electro-valva
Spacer	Avståndsbricka	Paksuuskiila	Cala de fixare
Spacer plate	Plåt mellanlägg	Välitukipelti	Tabla de legatura
Spain	Spanien	Espanja	Spania
Spare parts catalogue	Reservdelskatalog	Luettelo PR	Catalog
Spotlight	Strålkastare	Kuvanheitin	Proiector
Spray nozzle	Munstycke	Suutin	Jiglor
Spring	Fjäder	Ujousi	Resort-arc
Steering cylinder	Styrningsdomkraft	Ohjaussylinteri	Cric de directie
Step	Fotsteg	Astinlauta	Miscare picior
Stop	Anslag	Rajoitin	Piedica opritor
Support	Stötta	Tuki	Cala de sprijin, reazem de panta
Sweden	Sverige	Ruotsi	Suedia
Switch	Strömbrytare	Kytkin	Intrerupator
Terminal partition block	Slutväggsblock	Väliseinälohko pääte	Bloc închidere terminala
Terrestrial interface block	Jordanslutningsblock	Maaliitoslohko	Bloc de legatura la pamânt
Tilt	Lutning	Kaltevuus	Deversare
Tilt detector	Lutningsdetektor	Kaltevuusanturi	Detector de deversare
Tooth lock washer	Tandad låsbricka	Hammaslaatta	Inel dintat
T-piece	T-koppling	T-kappale	Te
Traction battery	Drivbatteri	Vetoparisto	Baterie de tractiune

